

**PARTS LIST**

**Backup Sensor Attachment Kit  
P/N 08V67-SZN-200A**

Control unit

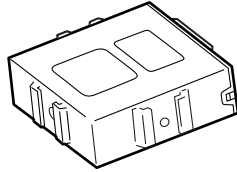

Buzzer

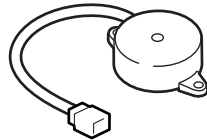

Backup sensor harness

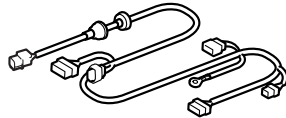

Backup sensor subharness

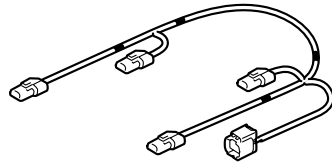

Control unit bracket

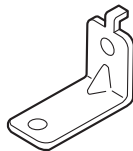

Switch

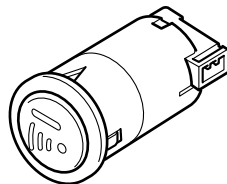

7 Aluminum tapes



Screw grommet



Fuse seal

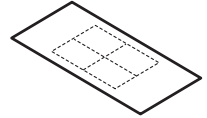

Self-tapping screw



12 Wire ties

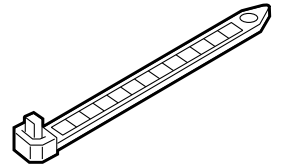

2 Corner Sensor clips (white)

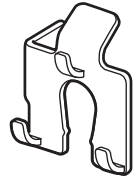

2 Center sensor clips (Black)

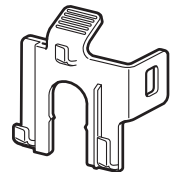

Switch bracket

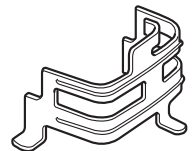

Wire tie with holder

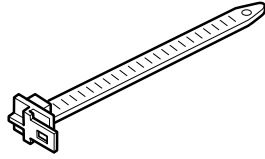

Narrow wire tie

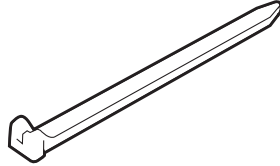

Accessory User's Information Manual

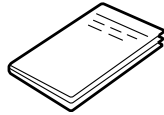

**Backup Sensor Kit  
P/N 08V67-SZN-200K**

2 Corner sensors

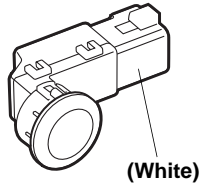

2 Center sensors (Larger than the corner sensors)

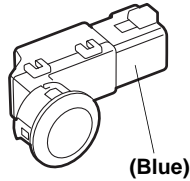

**TOOLS AND SUPPLIES REQUIRED**

- Phillips screwdriver
- Flat-tip screwdriver
- Shop towel
- Ratchet
- 8 mm and 10 mm Sockets
- Pushpin
- Drill
- 3 mm Drill bit
- 24 mm and 26 mm Hole saws
- Tape measure
- Eye protection (safety goggles, face shield, etc.)
- 10 mm Wrench
- File
- Diagonal cutters
- Isopropyl alcohol
- Plastic trim tool (T/N SILTRIMTL10)
- Scissors
- Felt-tip pen
- Blanket
- Electrical tape

***Illustration of the Backup Sensors Installed on the Vehicle***

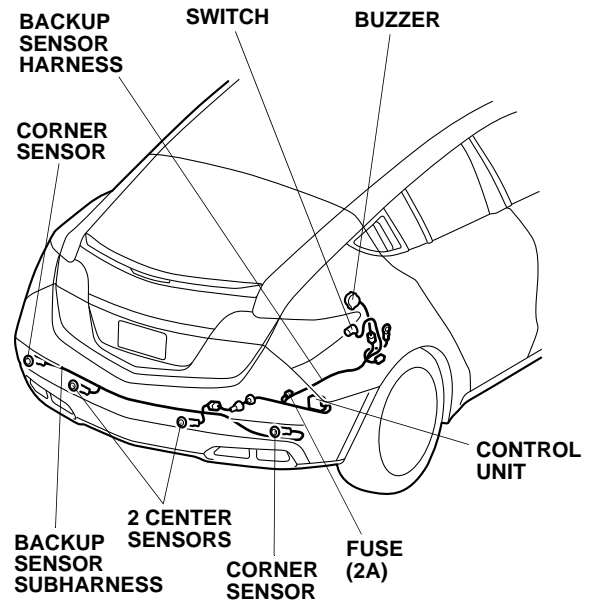

## INSTALLATION

**Client Information:** The information in this installation instruction is intended for use only by skilled technicians who have the proper tools, equipment, and training to correctly and safely add equipment to your vehicle. These procedures should not be attempted by “do-it-yourselfers.”

1. Make sure you have the anti-theft code for the radio and navigation system if equipped, then write down the radio station presets.
2. Open the hood. Disconnect the negative cable from the battery.

### Removing the Vehicle Parts

3. Remove the front cargo floorboard.

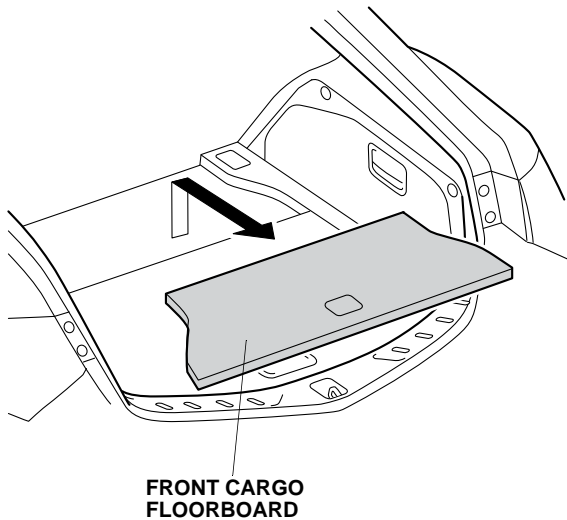

4. Remove the left and right rear tie-down hooks (open the lid and loosen one screw each).

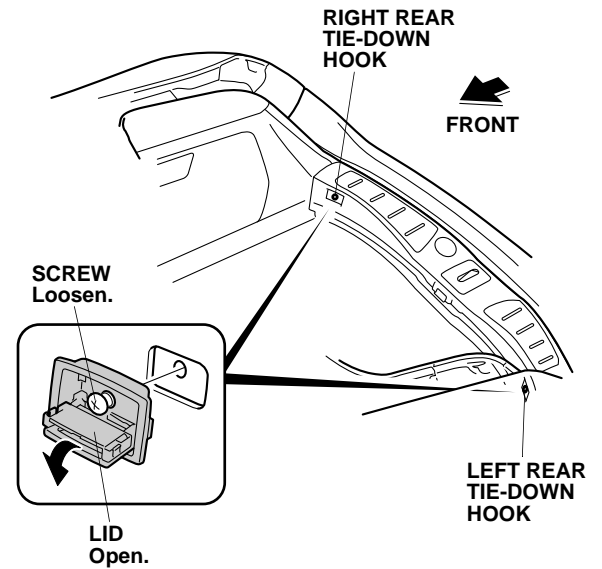

5. Pull away the weatherstrip from around the rear panel trim.

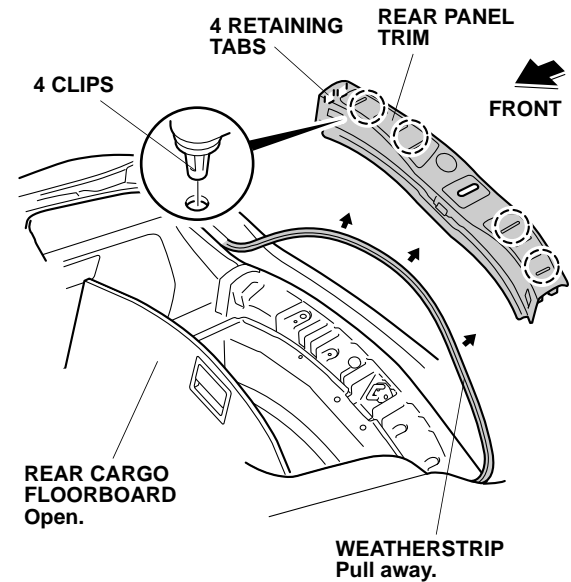

6. Open the rear cargo floorboard and remove the rear trim panel trim (four retaining tabs and four clips). Close the rear cargo floorboard.

- Remove the right front tie-down hook (open the lid and loosen one screw).

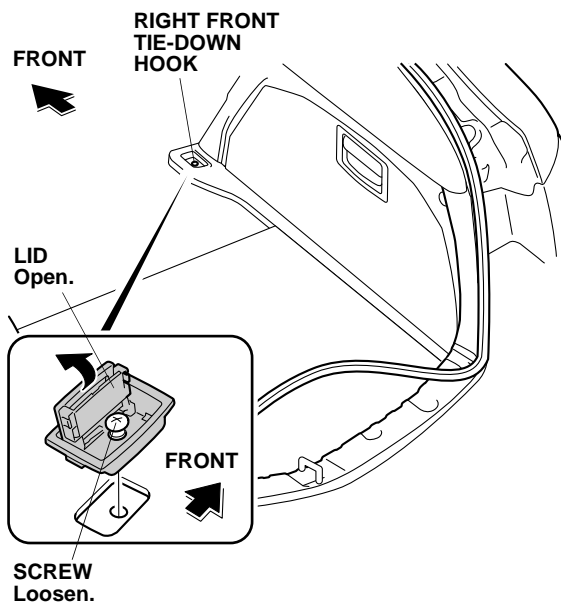

- Remove the rear bumper (four caps, two clips, six screws, two self-tapping screws, and four bolts). Place the rear bumper on a blanket.  
NOTE: Have an assistant help you remove the rear bumper.

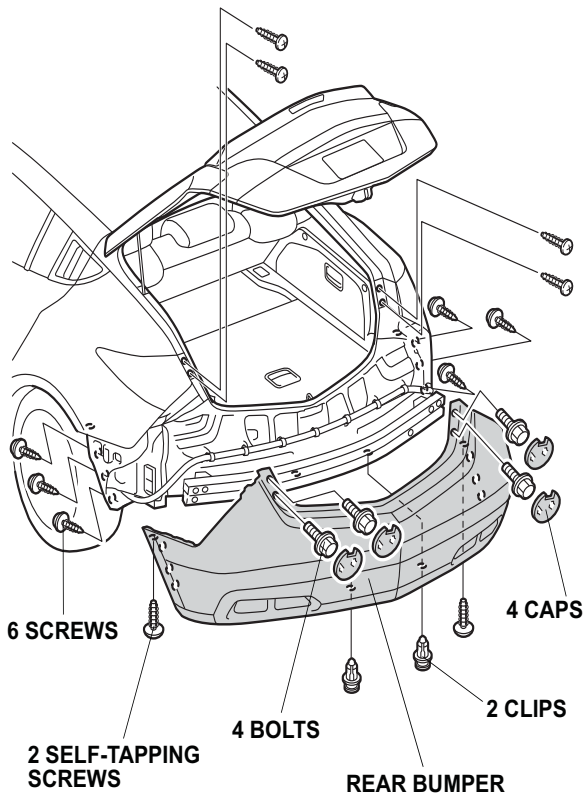

- Fold down the right rear seat back.

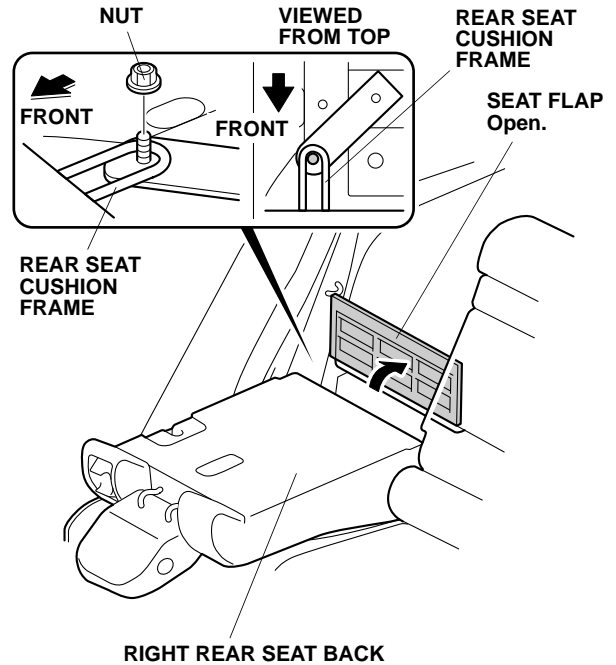

- Open the seat flap, and remove the nut that secures the rear seat cushion frame.
- Remove the rear seat cushion (pull up to remove the two rear seat cushion frames, and unplug the vehicle connectors).

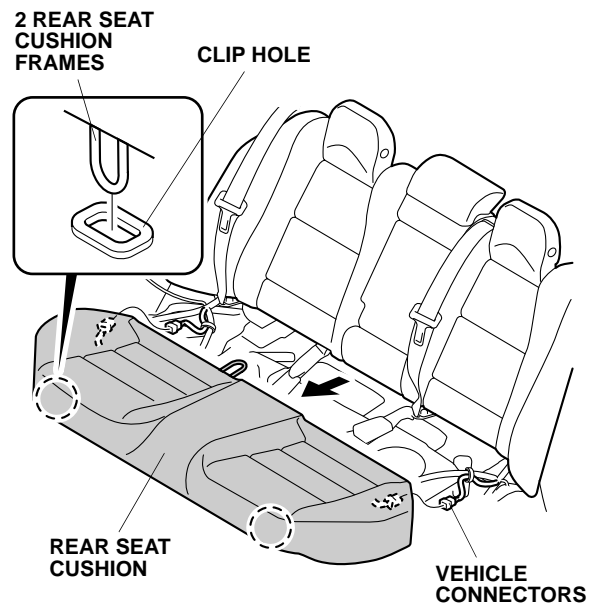

12. Remove the right rear seat side cover (one bolt and one clip).

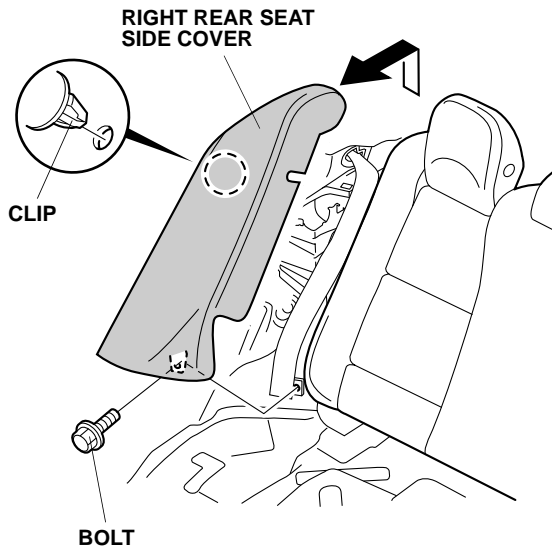

13. Remove the right rear side panel (lift the lever).

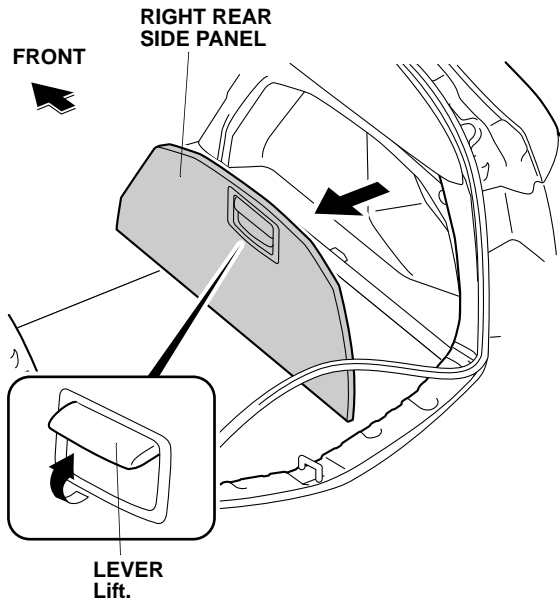

14. Remove the tool box.

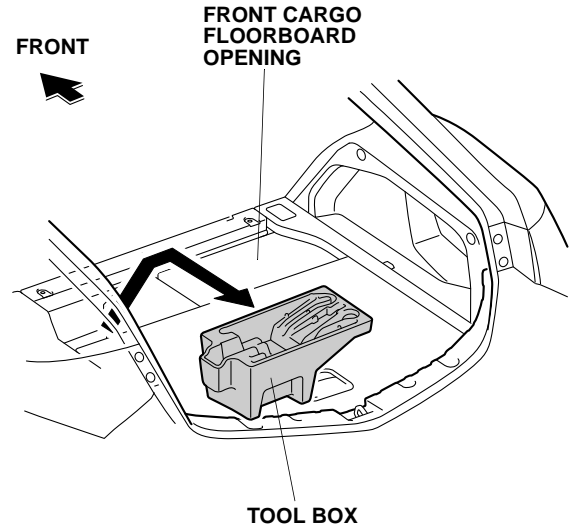

15. Remove the seat flap (two clips, one screw, and two tabs).

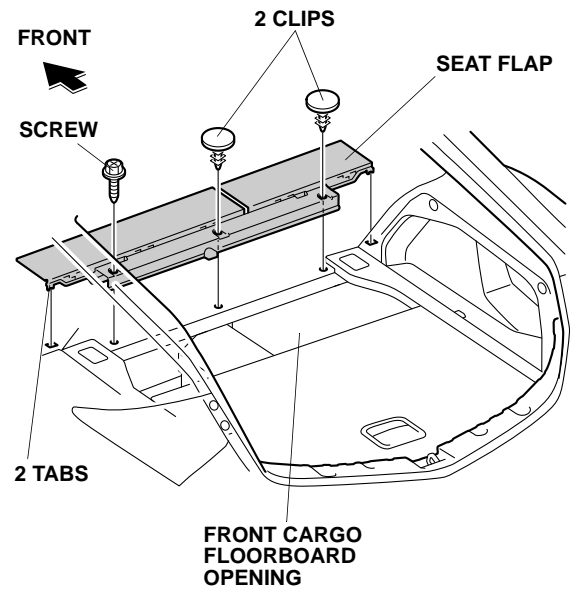

- Pull away the weatherstrip from around the right rear side trim panel as shown.

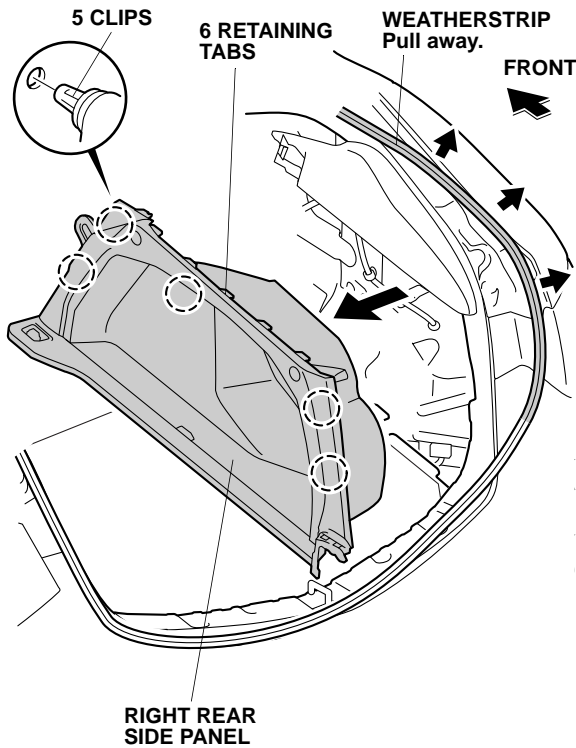

- Remove the right rear side trim panel (six retaining tabs and five clips).
- Open the rear cargo floor board, and release the cargo lining (three clips).

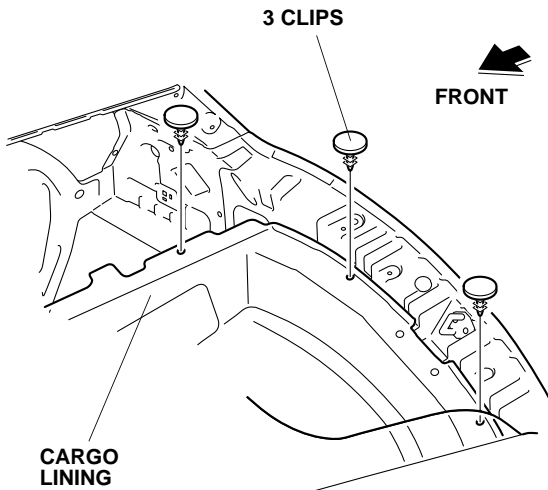

## Installing the Control Unit

- Attach the control unit bracket to the control unit.

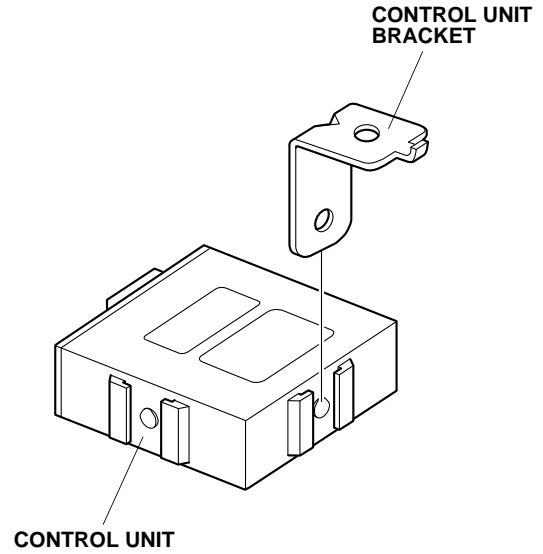

If the vehicle is equipped with the accessory trailer hitch, go to step 22; if not, go to step 20.

- Install the screw grommet into the vehicle panel.

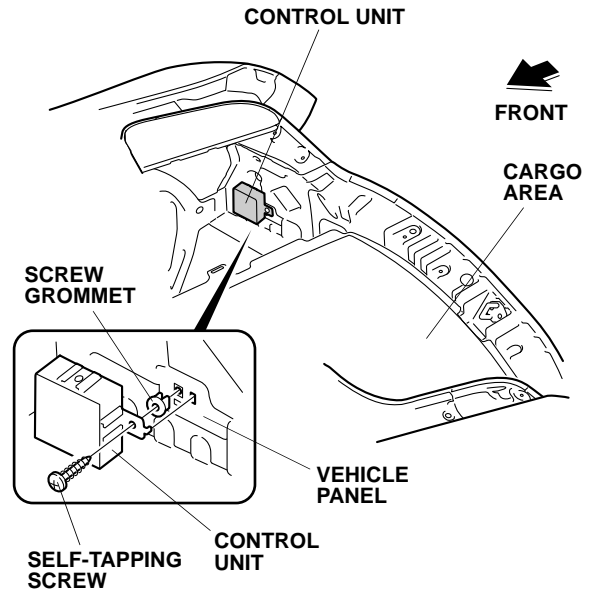

- Align the control unit bracket to the hole in the vehicle panel as shown. Install the control unit to the vehicle panel with one self-tapping screw. Go to step 23.

22. With the trailer hitch: Remove one self-tapping screw from the vehicle panel. Align the control unit bracket to the hole in the vehicle panel as shown. Secure the control unit and trailer unit to the vehicle panel with the self-tapping screw just removed.

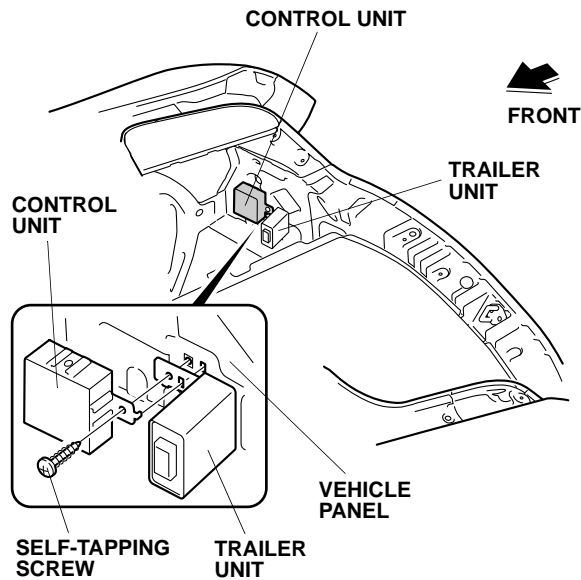

### Routing the Backup Sensor Harness

23. Using isopropyl alcohol on a shop towel, thoroughly clean the area where the fuse label will attach. Attach the 2A fuse label to the fuse case on the backup sensor harness.

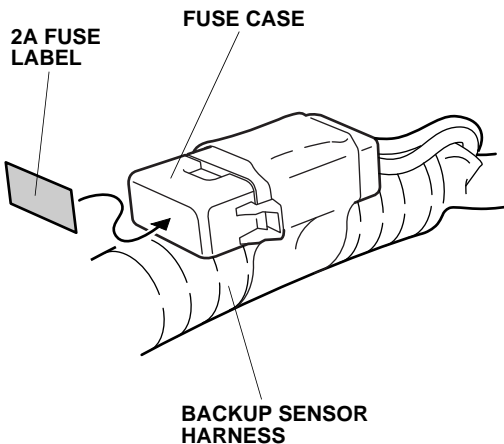

24. Plug the backup sensor harness 14-pin connector into the control unit.

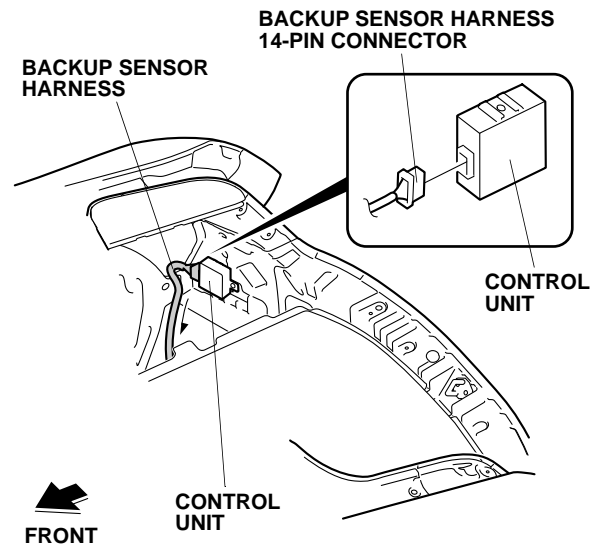

25. Route the backup sensor harness as shown.  
26. Remove the vehicle grommet from the vehicle panel.

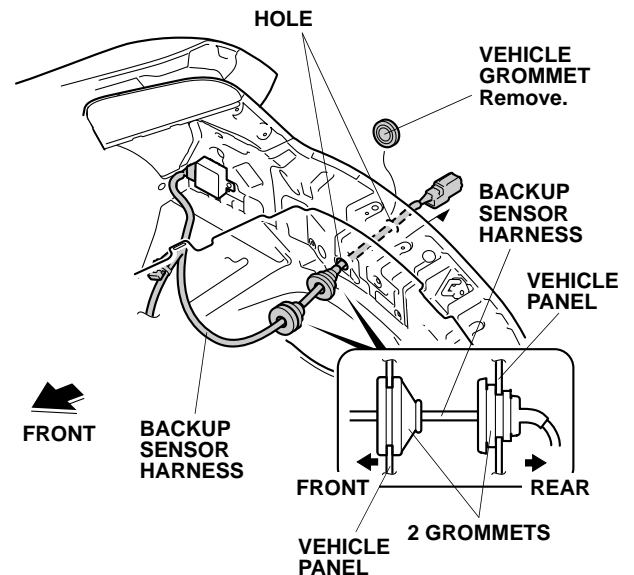

27. Route the backup sensor harness through two holes and secure the two grommets on the backup sensor harness to the vehicle panel as shown.  
NOTE: Do not pull on the backup sensor harness when installing the grommets.

- Using isopropyl alcohol on a shop towel, thoroughly clean the areas where the aluminum tapes will attach.

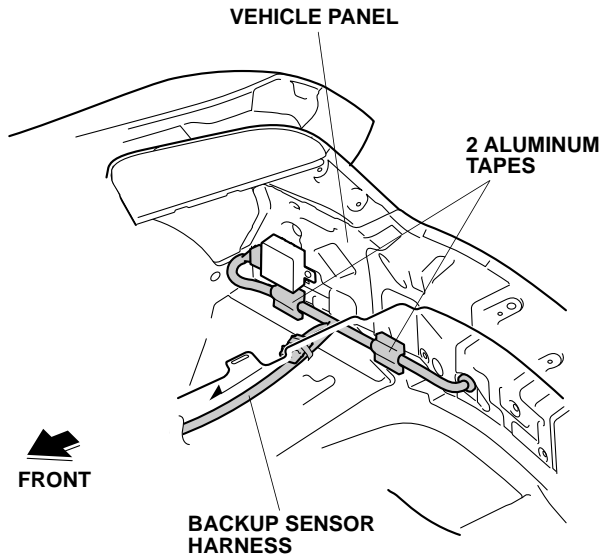

- Route the backup sensor harness and secure it to the vehicle panel with two aluminum tapes.

If the vehicle is equipped with the accessory trailer hitch, go to step 32; if not, go to step 30.

- Remove the tape and dummy connector from the vehicle 8-pin connector.

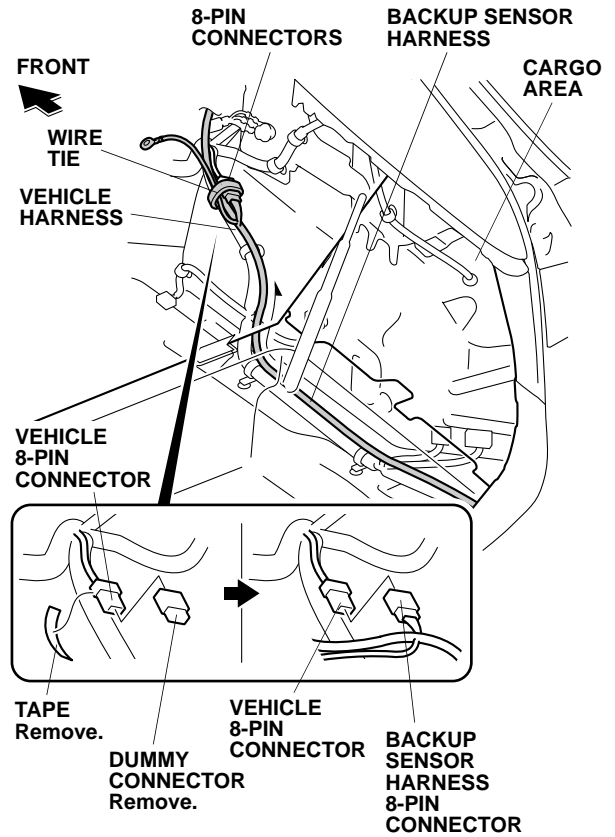

- Route the backup sensor harness and plug the vehicle 8-pin connector to the backup sensor harness 8-pin connector. Secure the 8-pin connectors to the vehicle harness with one wire tie. Go to step 34.



32. With trailer hitch: Remove the tape from the trailer hitch harness 8-pin connector.

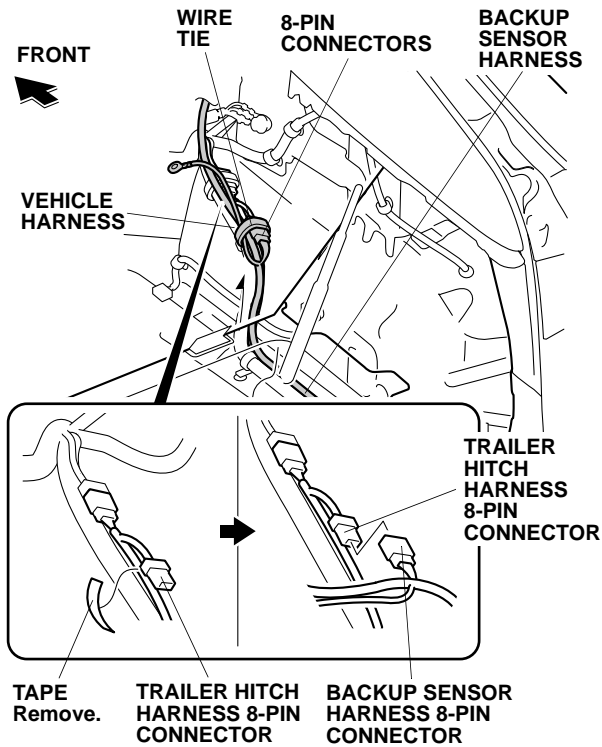

33. Route the backup sensor harness and plug the trailer hitch harness 8-pin connector to the backup sensor harness 8-pin connector. Secure the 8-pin connectors to the vehicle harness with one wire tie.

34. Remove the vehicle ground bolt. Secure the backup sensor harness ground terminal and the vehicle ground terminal with the vehicle ground bolt.

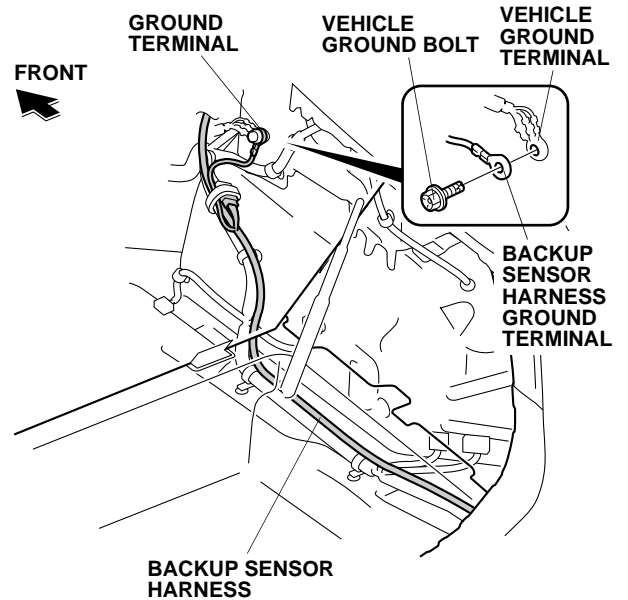

35. Secure the backup sensor harness to the vehicle harness with three wire ties.

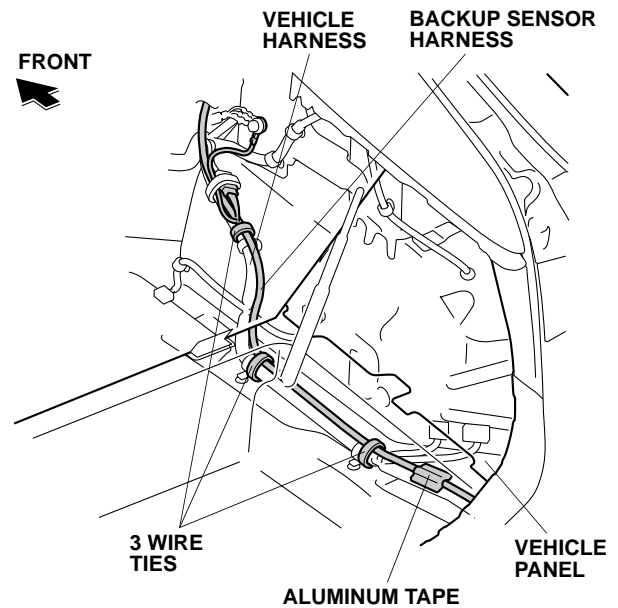

36. Using isopropyl alcohol on a shop towel, thoroughly clean the area where the aluminum tape will attach.  
 37. Secure the backup sensor harness to the vehicle panel with one aluminum tape as shown.  
 38. Close the rear cargo floorboard.

39. Using isopropyl alcohol on a shop towel, thoroughly clean the area where the buzzer will attach.

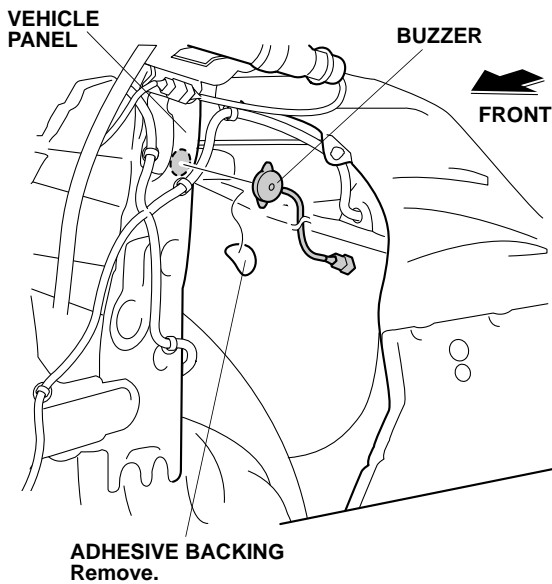

40. Remove the adhesive backing from the buzzer and attach it to the vehicle panel as shown.

41. Route the buzzer harness along the vehicle harness.

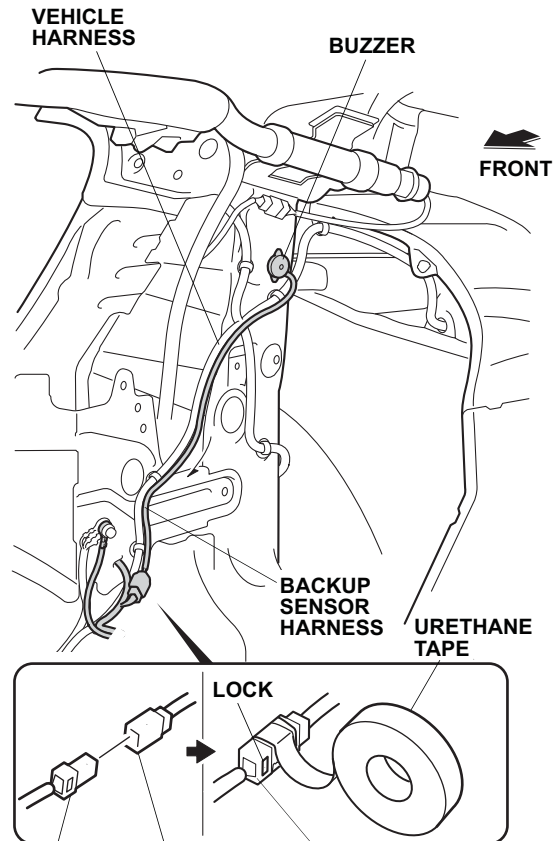

BACKUP SENSOR HARNESS 2-PIN CONNECTOR      BUZZER 2-PIN CONNECTOR      BACKUP SENSOR HARNESS 2-PIN CONNECTOR

42. Plug the backup sensor harness 2-pin connector to the buzzer 2-pin connector.
43. Cut one urethane tape as shown. Attach the piece of urethane tape around the buzzer 2-pin connector.
- NOTE: Do not cover the lock on the backup sensor harness 2-pin connector with the urethane tape.

- Secure the 2-pin connectors to the vehicle harness and the backup sensor harness with one wire tie.

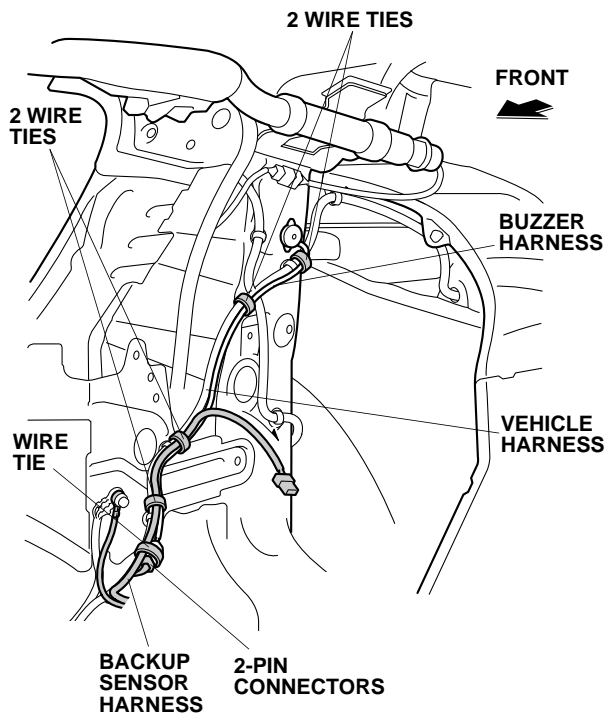

- Route the backup sensor harness along the vehicle harness.
- Secure the backup sensor harness and the buzzer harness to the vehicle harness with two wire ties.
- Secure the buzzer harness to the vehicle harness with two wire ties.

## Installing the Switch

- Using a tape measure and felt-tip pen, measure and mark the right rear side trim as shown.

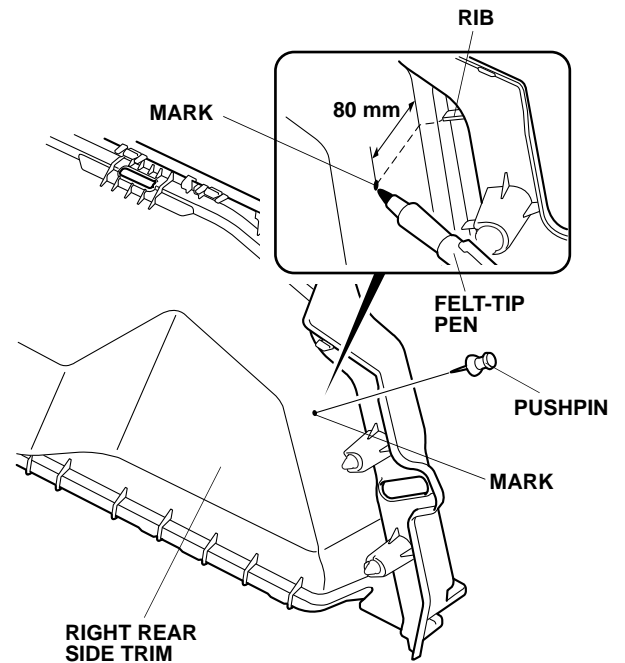

- Using a pushpin, pierce the mark made on the right rear side trim.
- While wearing eye protection, drill the pierced hole with a 3 mm drill bit, then enlarge the hole with a 26 mm hole saw. Remove any burrs.

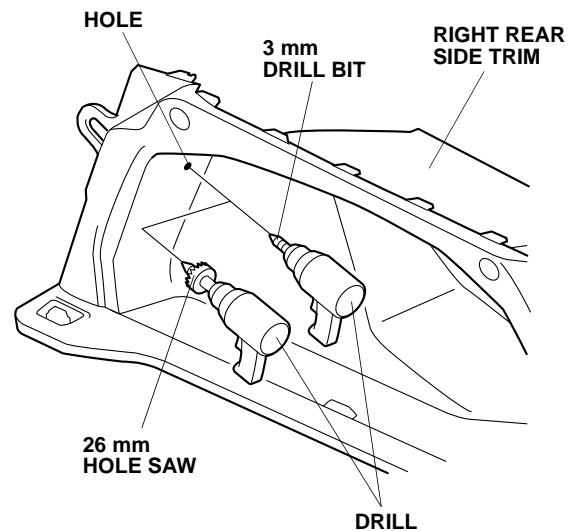

51. Remove the adhesive backing and attach the remaining urethane tape cut in step 43 to the switch bracket as shown.

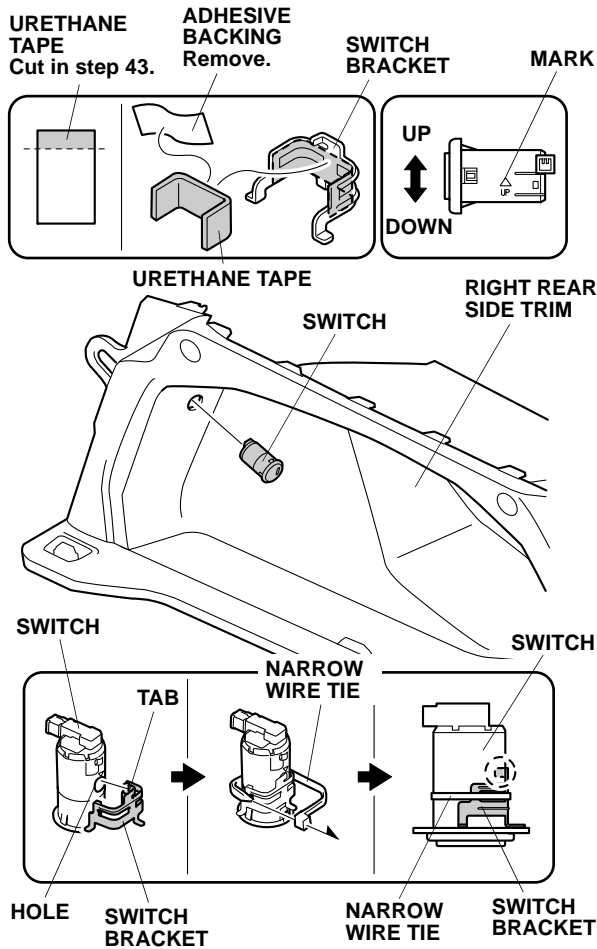

52. Install the switch into the right rear side trim.  
**NOTE:** Make sure the switch is installed in the correct orientation.
53. Align the tab on the switch bracket to the hole on the switch and secure the switch bracket to the switch with one narrow wire tie.  
**NOTE:** Firmly press the switch bracket against the right rear side trim and secure it with one narrow wire tie. Make sure there is no clearance between the switch and right rear side trim.

54. Plug the backup sensor harness 3-pin connector to the switch.

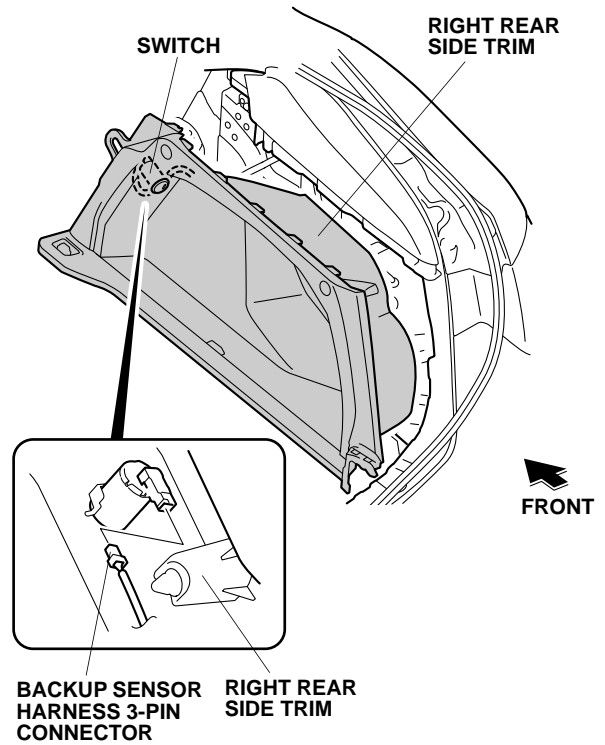

55. Reinstall the right rear side trim.

## Installing the Backup Sensors

56. Working inside of the rear bumper, use a pushpin to pierce eight scribe marks as shown.

NOTE: Make sure to pierce the scribe marks perpendicularly to the rear bumper.

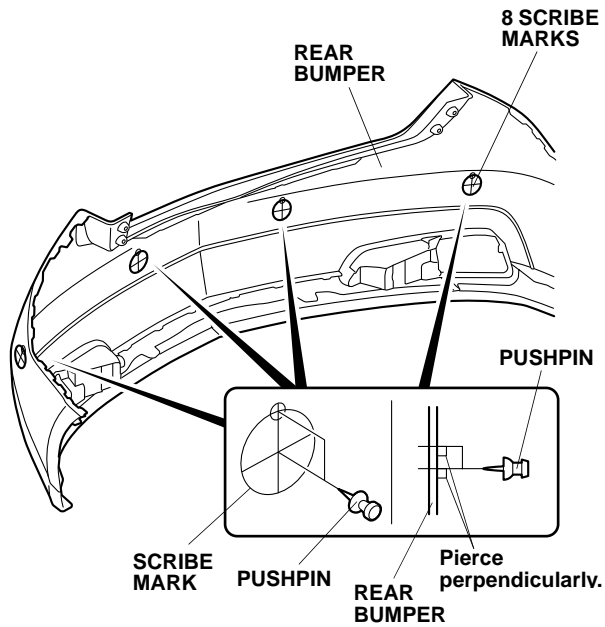

57. Working on the outer surface of the rear bumper, use a 3 mm drill bit to drill the eight marks pierced in step 56. Wear eye protection

NOTE: Make sure to drill perpendicularly to the rear bumper.

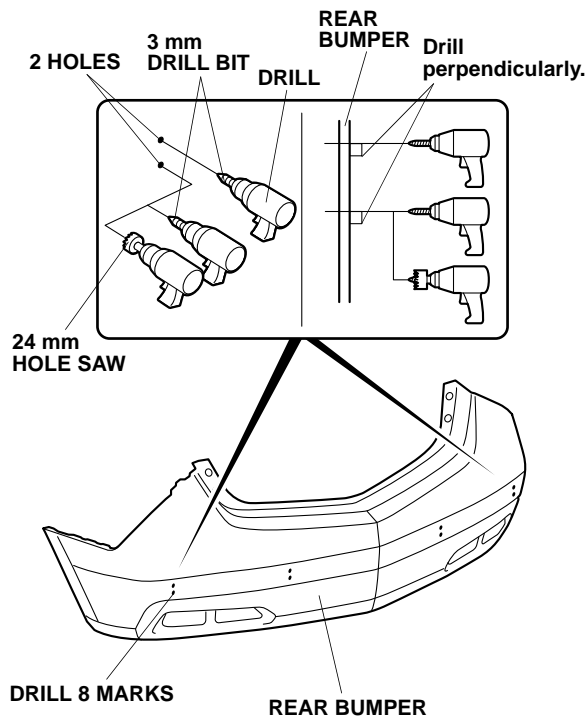

58. Drill two outer lower holes with a 24 mm hole saw.  
NOTE: Make sure to drill perpendicularly to the rear bumper. Remove any burrs.

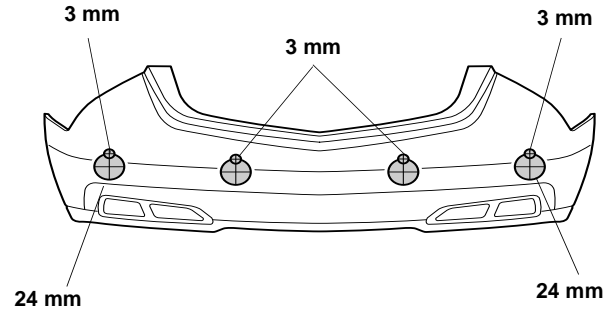

59. Drill two inner lower holes with a 26 mm hole saw.  
 NOTE: Make sure to drill perpendicularly to the rear bumper. Remove any burrs.

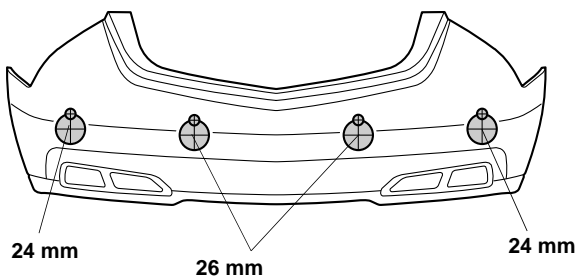
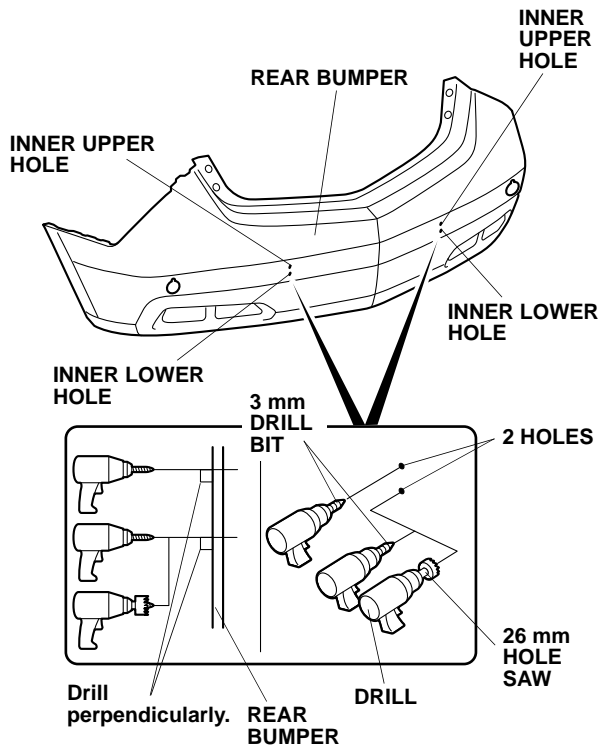

60. Insert the corner sensor (White) and center sensor (Blue) to the rear bumper.

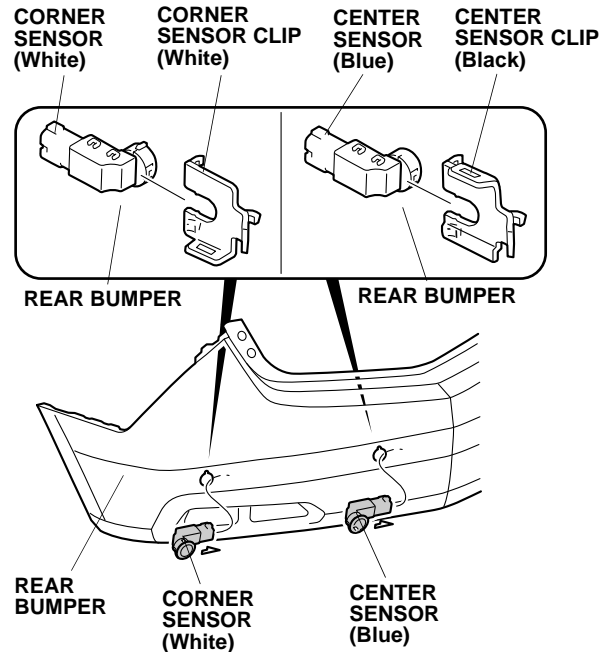

61. Secure the corner sensor (White) with a corner sensor clip (White) and secure the center sensor (Blue) with a center sensor clip (Black) as shown.  
 62. Insert the corner sensor (White) and center sensor (Blue) to the rear bumper.

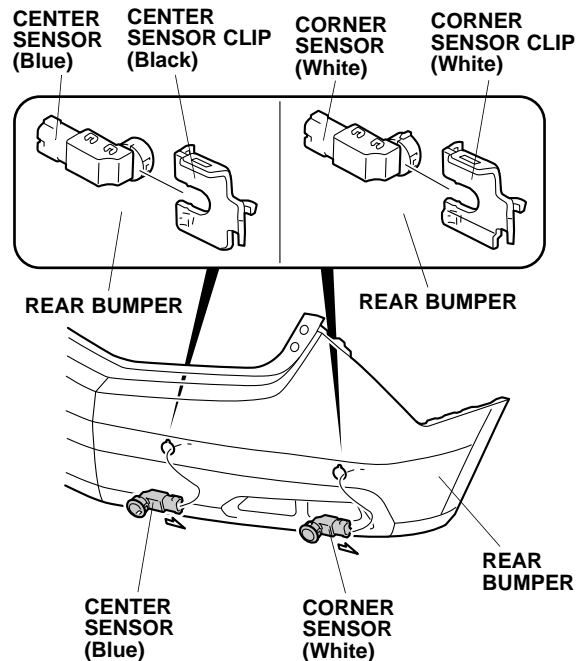

63. Secure the corner sensor (White) with a corner sensor clip (White) and secure the center sensor (Blue) with a center sensor clip (Black) as shown.

64. Plug four backup sensor subharness 2-pin connectors to two center sensors (Blue) and two corner sensors (White).

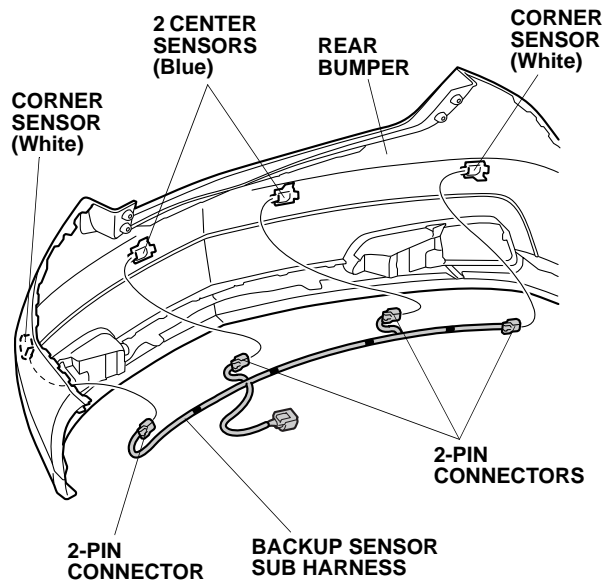

65. Route along the character line on the back bumper.

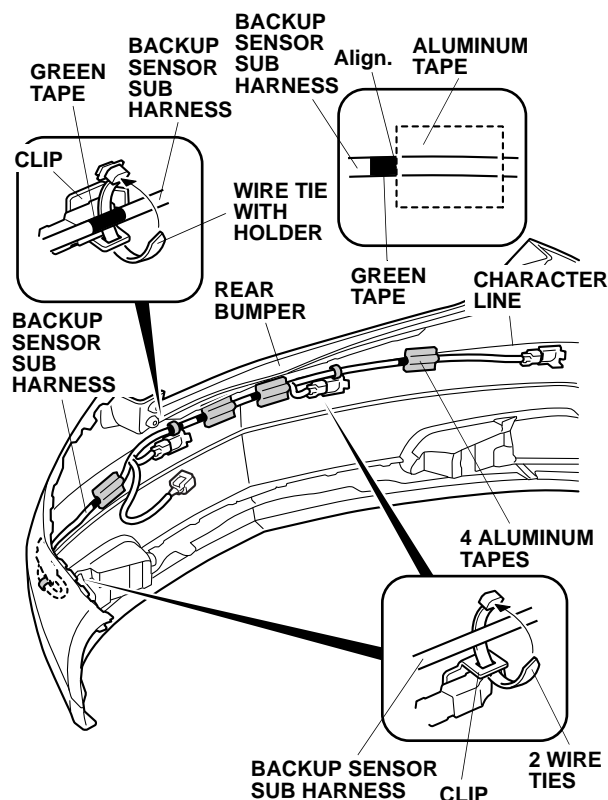

66. Secure the center sensor clip (Black) to the green tape on the backup sensor sub harness with one wire tie with holder.
67. Secure the center sensor clip (Black) to the backup sensor sub harness with two wire ties.

68. Using isopropyl alcohol on a shop towel, thoroughly clean the areas where the aluminum tapes will attach.
69. Secure the backup sensor subharness to the rear bumper with four aluminum tapes at the green tape on the backup sensor subharness as shown.
70. Insert one wire tie with holder into the backup sensor subharness 8-pin connector.

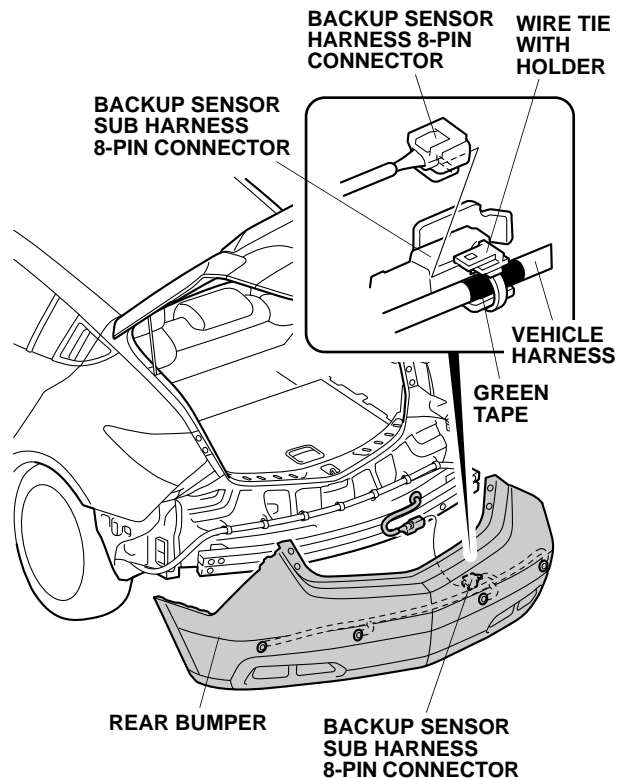

71. Plug the backup sensor sub harness 8-pin connector to the backup sensor harness 8-pin connector.
72. Reinstall the rear bumper.  
NOTE: Have an assistant help you when installing the rear bumper.
73. Check that all wire harnesses are routed properly and all connectors are plugged in.
74. Reconnect the negative cable to the battery.
75. Enter the client's anti-theft code for the audio and navigation system if equipped, and reset the radio station presets.
76. Reset the clock.
77. Adjust the volume control of the buzzer then reinstall all removed parts.
78. Check that the backup sensors work properly as described in the Accessory User's Information Manual supplied with the backup sensor kit.

## Buzzer Volume Control

The original volume setting is turned to maximum volume. The volume level can be adjusted by turning the volume control knob on the control unit using a small flat-tip screwdriver.

