

10001341



Applies To: 2001-03 MDX - ALL

March 31, 2003

2001-03 MDX: Remote Audio Controls Do Not Work Properly

SYMPTOM

When you turn the steering wheel, the remote audio switches do not work properly.

PROBABLE CAUSE

The steering shaft resistance varies because the ground path does not have full contact through the bearing.

CORRECTIVE ACTION

Dimple the copper shield on the steering column ball bearing in eight places.

WARRANTY CLAIM INFORMATION

In warranty: The normal warranty applies.

Operation Number: 510020

Flat Rate Time: 1.5 hours

Failed Part: P/N 53200-S3V-A02

Defect Code: 066

Contention Code: B02

Template ID: 03-015A

Skill Level: Repair Technician

Out of warranty: Any repair performed after warranty expiration may be eligible for goodwill consideration by the District Parts and Service Manager or your Zone Office. You must request consideration, and get a decision, before starting work.

REPAIR PROCEDURE

NOTE: Before doing any repairs or services, review the SRS components in this area (see page 23-15 of the 2001-02 and 2003 MDX Service Manuals) and the precautions and procedures (see page 23-16).

1. Make sure you have the anti-theft codes for the radio and the navigation system (if equipped). Write down your customer's radio station presets.
2. Disconnect the battery negative cable. Wait at least 3 minutes before continuing.

3. Remove the access panel from under the steering wheel.
4. 2001-02 models: Unplug the cable reel 2P connector from the driver's airbag 2P connector.

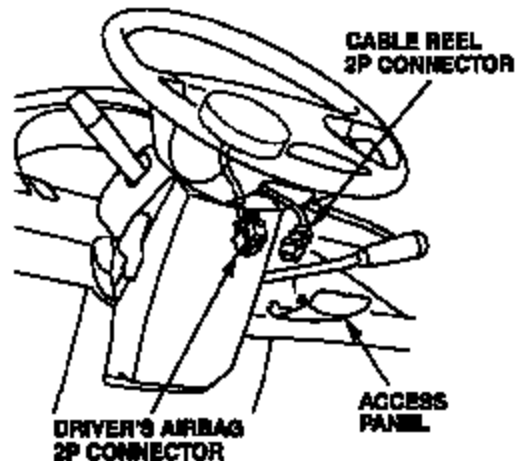

2003 models: Unplug the cable reel 4P connector from the driver's airbag 4P connector.

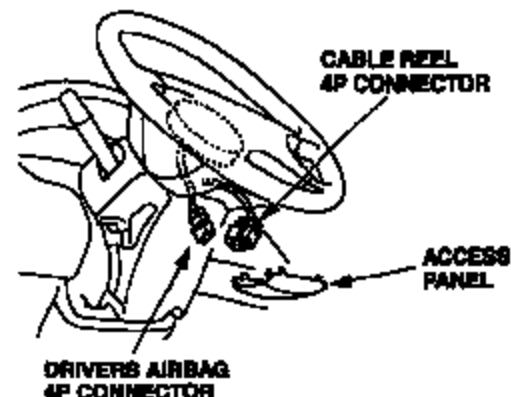

NOTE: When unplugged, the driver's airbag connector is automatically shorted.



10001341

5. Remove the two steering wheel covers. Use a Torx T30 bit to remove the two Torx bolts. Unplug the horn wire, and remove the driver's airbag.

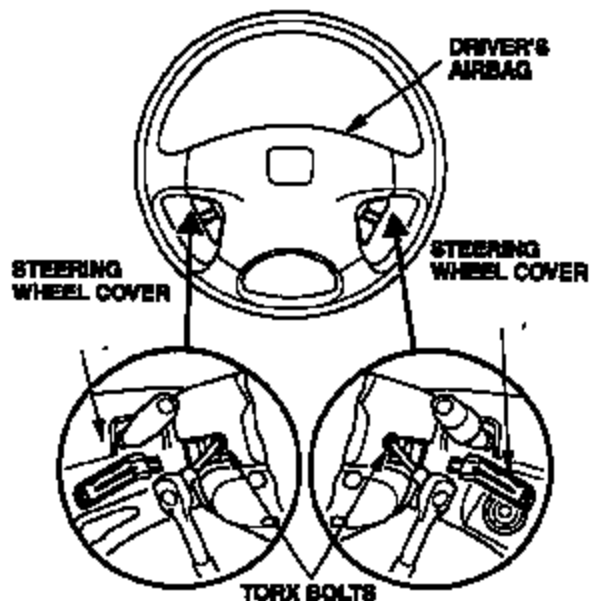

6. 2001-02 models: Unplug the connectors from the remote audio and cruise control switches.

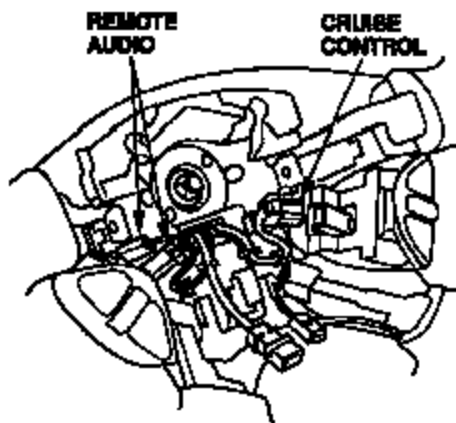

- 2003 models: Unplug the connectors from the horn, remote audio, and cruise control switches.

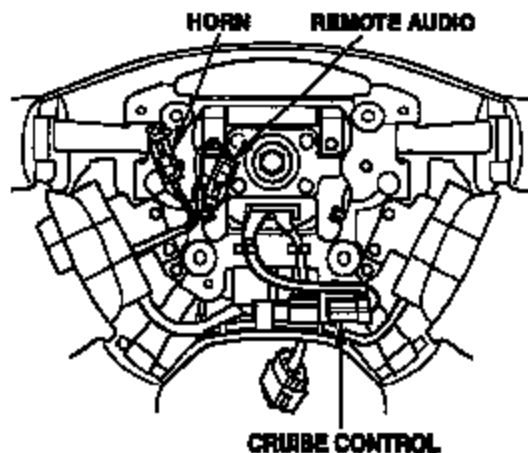

7. Make sure the front wheels are aligned straight ahead.

8. 2001-02 models: Loosen the steering wheel nut. Make an alignment mark on the steering wheel shaft with a paint stripe.

2003 models: Loosen the steering wheel bolt. Make an alignment mark on the steering wheel shaft with a paint stripe.

9. Using a commercially available steering wheel puller, release the steering wheel from the steering shaft. While pulling the steering wheel, note these items:

- Do not tap on the steering wheel or the steering column shaft when removing the steering wheel.
- If you thread the puller bolts into the wheel hub more than five threads, the bolts would hit the cable reel and damage it. To prevent this, install a pair of jam nuts five threads up on each puller bolt.

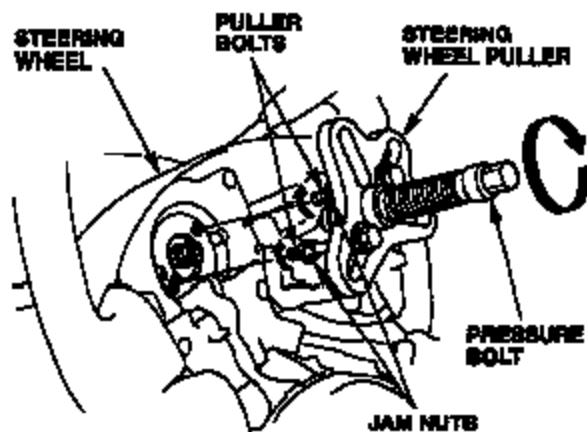

10. Remove the steering wheel puller. Remove the nut or bolt, and then remove the steering wheel from the steering column.

11. Remove the dashboard lower cover.

12. Remove the upper and lower steering column covers.

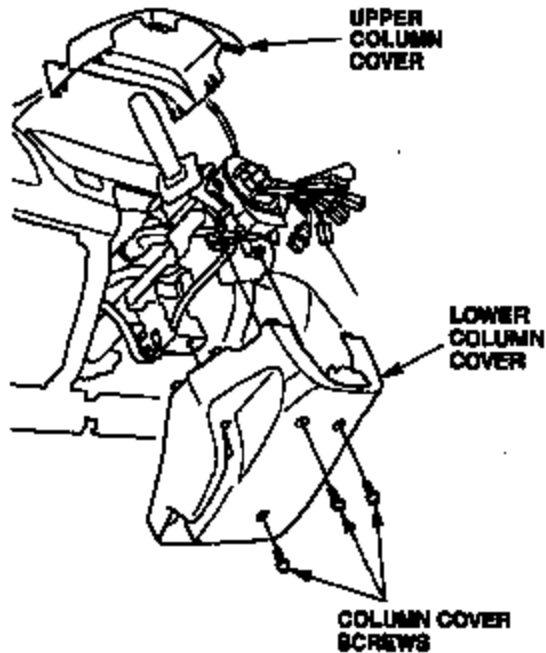

13. 2001-02 models: Unplug the SRS main harness 2P connector, and then detach the dashboard wire harness 4P connector from the cable reel. Remove the screws from the cable reel, and then remove the cable reel from the column.

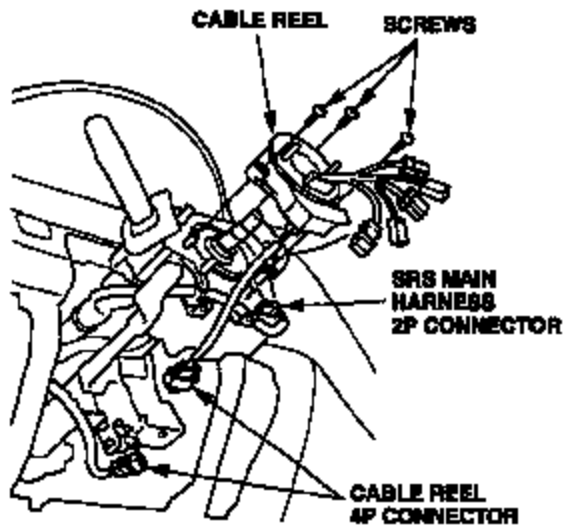

- 2003 models: Unplug the SRS main harness 4P connector and the dashboard wire harness 5P connector from the cable reel 4P and 5P connectors. Release the tab, and then remove the cable reel from the column.

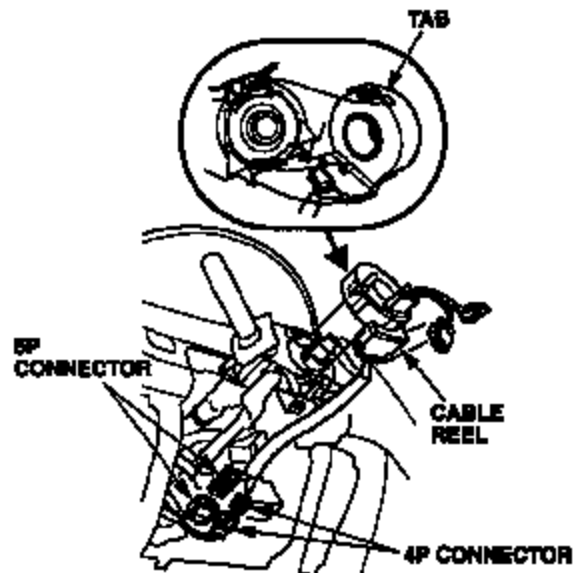

14. 2001-02 models: Unplug the light switch 14P connector and both wiper/washer 8P connectors. Remove the three screws from the combination switch assembly, and then remove the combination switch from the steering column.

- 2003 models: Unplug the light switch 14P connector, the steering angle sensor 5P connector, and both wiper/washer 8P connectors. Remove the three screws from the combination switch assembly, and then remove the combination switch from the steering column.

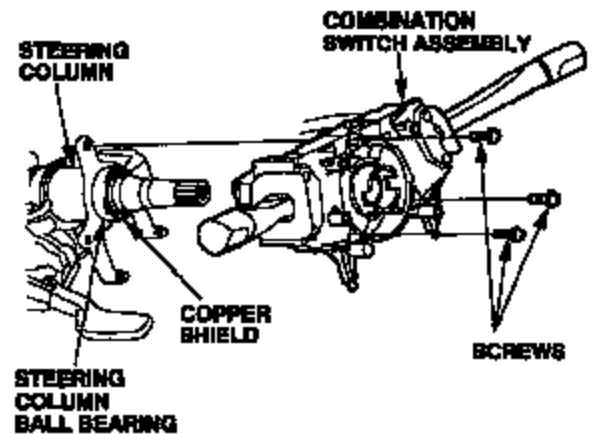

15. Use a small, flat-tipped screwdriver to lightly dimple the shield in eight places as shown.

NOTICE

Do not press too hard with the screwdriver when dimpling the shield. The dimples should be deep enough to catch your fingernail on. If the dimples are too deep, the steering effort will be too high, and the steering column will have to be replaced.

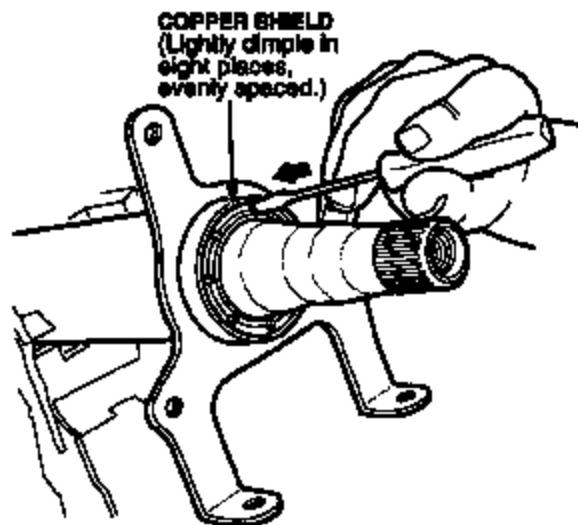

16. 2001-02 models: Reinstall the combination switch assembly, and secure it with the three original screws. Reconnect the light switch 14P connector and both wiper/washer 8P connectors.

2003 models: Reinstall the combination switch assembly, and secure it with the three original screws. Reconnect the light switch 14P connector, the steering angle sensor 5P connector, and both wiper/washer 8P connectors.

17. Position the cancel sleeve on the combination switch assembly so that the projections on the sleeve are aligned vertically.

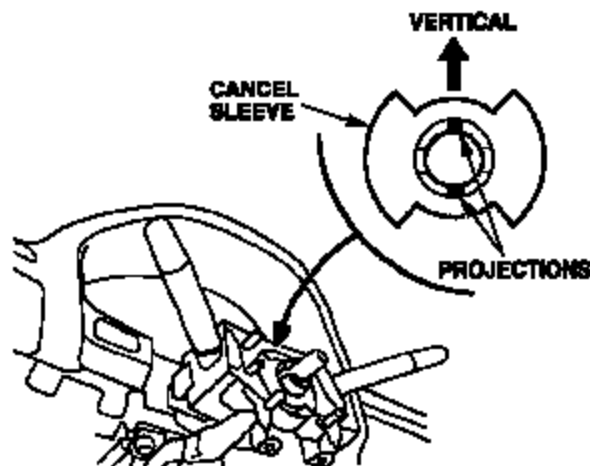

18. Carefully reinstall the cable reel with the original screws.

19. 2001-02 models: Reconnect the SRS main harness 2P connector and the cable reel 2P connector, and then plug the dashboard wire harness 4P connector and cable reel 4P connector together.

2003 models: Reconnect the SRS main harness 4P and dashboard wire harness 5P connectors to the cable reel 4P and 5P connectors.

20. Reinstall the upper and lower steering column covers with the original screws.

21. If needed, center the cable reel by first rotating the reel clockwise until it stops and then rotating it counterclockwise (approximately two and a half turns) until the arrow mark on the reel label points straight up.

22. 2001-02 models: Line up the paint marks, and reinstall the steering wheel. Torque the nut to 49 N-m (36 lb-ft).

2003 models: Line up the paint marks, and reinstall the steering wheel. Torque the bolt to 36 N-m (26 lb-ft).

23. 2001-02 models: Plug in the connectors for the remote audio and cruise control switches.

2003 models: Plug in the connectors for the horn, remote audio, and cruise control switches.

24. Reconnect the horn wire, and reinstall the driver's airbag. Torque the bolts to 9.8 N-m (7.2 lb-ft). Reinstall the steering wheel covers.

25. Reinstall the lower dashboard cover.

26. 2001-02: Reconnect the 2P cable reel connector to the driver's airbag 2P connector.

2003 models: Reconnect the 4P cable reel connector to the driver's airbag 4P connector.

27. Reinstall the upper and lower steering column covers.

28. Reconnect the battery negative cable.

29. Do the Idle learn procedure:

- Make sure all electrical items are turned off, then start the engine.
- Let the engine reach its normal operating temperature (the cooling fan cycles twice).
- Let the engine idle (throttle fully closed and with all electrical items off) for 10 minutes.

30. When you start the engine, check that the SRS system indicator comes on and then goes off after a few seconds.
31. Check the operation of the horn, the turn signals, the remote audio buttons, and the cruise control switches.
32. *2003 models only:* Initialize the driver's window auto-up feature:
 - Turn the ignition switch to ON (II).
 - Make sure the driver's window is fully closed.
 - Push down and hold the window switch. Make sure the window goes all the way down.
 - Pull back and hold the window switch. Make sure the window goes all the way up, then hold the switch for at least 2 more seconds.
33. Enter the anti-theft codes for the radio and the navigation system (if equipped), and then enter your customer's radio station presets.
34. Set the clock.