

theoretical calculations
driving at 1.7V @ 300mA
34.4 ohm
3.09 W

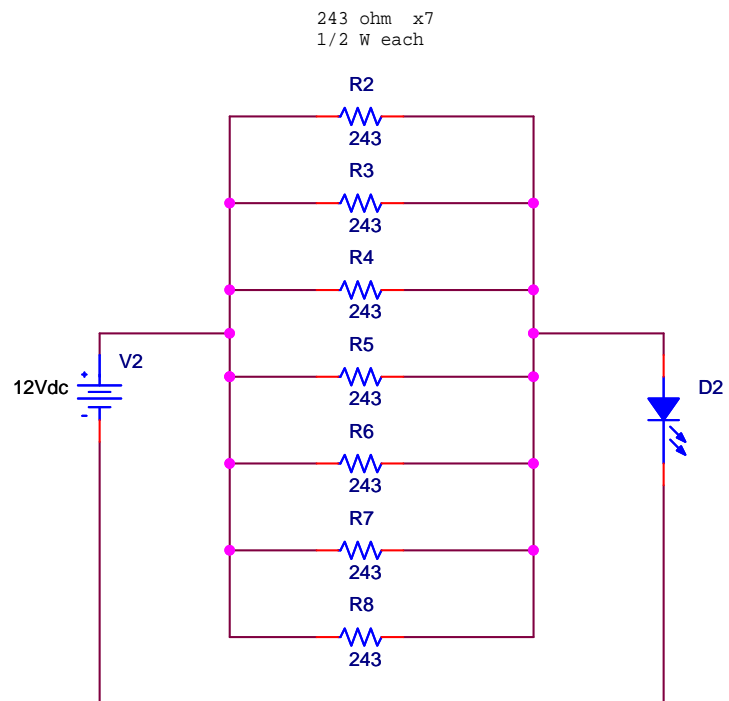

243 ohm x7
1/2 W each

OR

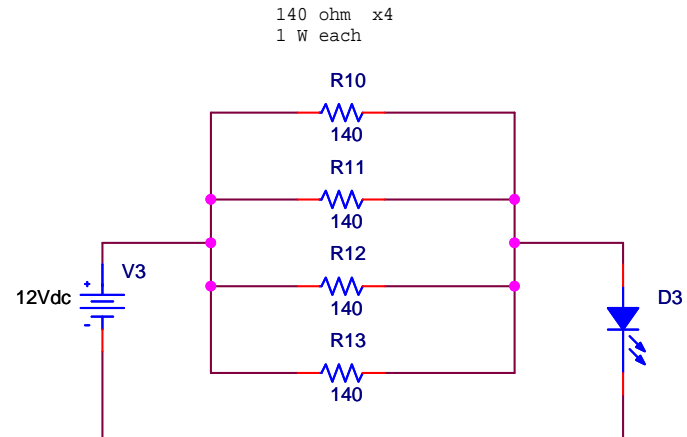

140 ohm x4
1 W each