

4. Apply Super High Temp Urea Grease (P/N 08798-9002) to the release fork (A), the release fork bolt (B), the release bearing (C), and the release fork set spring (D) in the shaded areas.

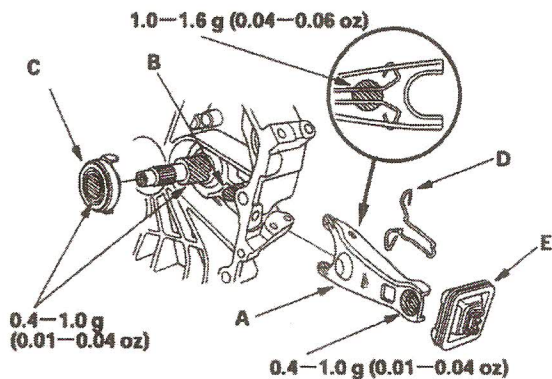

5. With the release fork slid between the release bearing pawls, install the release bearing on the mainshaft while inserting the release fork through the hole in the clutch housing.
6. Align the detent of the release fork with the release fork bolt, then press the release fork over the release fork bolt squarely.
7. Install the release fork boot (E). Make sure the boot seals around the release fork and clutch housing.
8. Move the release fork (A) right and left to make sure that it fits properly against the release bearing (B) and that the release bearing slides smoothly. Wipe off overflowed grease.

