

Applies To: **2014–15 RLX – ALL**  
**2016 RLX** – From VIN JHK4C1...GC000001 thru JHK4C1...GC000408

April 11, 2015

## P-AWS RTC Actuators Moan When Making Small Turns (Supersedes 13-041, dated March 14, 2015, to revise the information marked by the black bars)

### REVISION SUMMARY

Under PARTS INFORMATION, the RTC actuator part numbers were changed.

### SYMPTOM

A moaning or rubbing noise is heard from the rear when driving straight and making small side-to-side turning movements with the steering wheel.

### POSSIBLE CAUSE

There is a lack of lubrication in the P-AWS (precision all wheel steering) RTC (rear toe control) actuators.

### CORRECTIVE ACTION

Replace both RTC actuators.

### PARTS INFORMATION

Bracket-Mounting Bolt (Bolt-washer) (8 mm x 16 mm)  
 (two required):

P/N 93403-08016-08

Inner Self-Locking Nut (12 mm) (two required):

P/N 90213-SJ6-004

RTC Actuator (left):

P/N 52345-TY2-A14

RTC Actuator (right):

P/N 52340-TY2-A14

Outer Self-Locking Nut (12 mm) (two required):

P/N 90370-SJA-000

Rear Control Arm Adjusting Bolt (two required):

P/N 90178-TY2-A01

### WARRANTY CLAIM INFORMATION

The normal warranty applies.

OP#	Description	FRT
4191H6	Replace both RTC actuators.	1.0 hr
4165A0	Four wheel alignment.	0.4 hr

Failed Part: P/N 52340-TY2-A13

Defect Code: 07409

Symptom Code: 04201

Skill Level: Repair Technician

### DIAGNOSIS

Drive the vehicle forward and move the steering wheel slowly side to side to confirm the noise. Then drive the vehicle slowly in reverse and move the steering wheel in the same way that caused the vehicle to make noise when moving forward (the actuators are not operated in reverse).

- If the noise stops, go to REPAIR PROCEDURE.
- If the noise does not stop, this bulletin does not apply. Continue with normal troubleshooting procedures.



**CLIENT INFORMATION:** The information in this bulletin is intended for use only by skilled technicians who have the proper tools, equipment, and training to correctly and safely maintain your vehicle. These procedures should not be attempted by “do-it-yourselfers,” and you should not assume this bulletin applies to your vehicle, or that your vehicle has the condition described. To determine whether this information applies, contact an authorized Acura automobile dealer.

## REPAIR PROCEDURE

### RTC Actuator Removal

1. Raise the vehicle on a lift, and make sure it is securely supported.
2. Remove both rear wheels.
3. Disconnect the RTC actuator connectors.
4. Remove the RTC actuator harness bracket bolt.

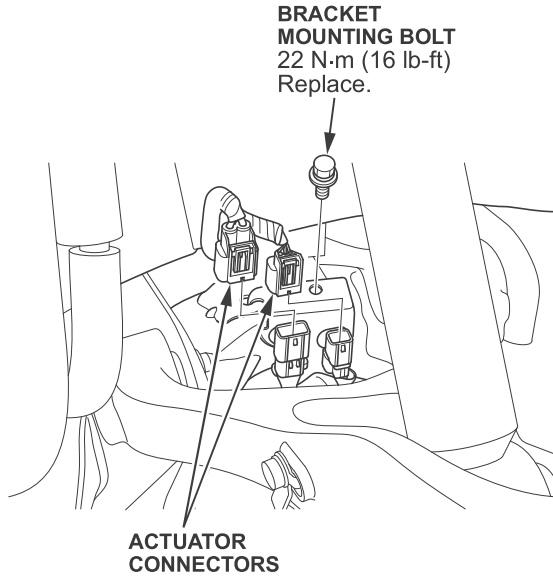

5. Note and mark the position of the adjusting cam plate and adjusting bolt in reference to the frame.
6. Remove the RTC actuator outer self-locking nut and washer.

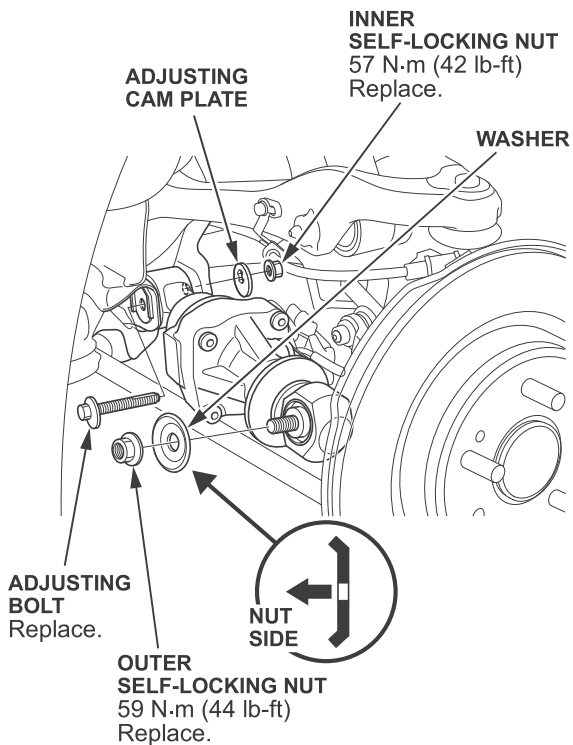

7. Remove the inner self-locking nut, the adjusting cam plate, and the adjusting bolt.
  8. Pry on the RTC actuator to remove it from the inner mount.
- NOTE: Do not loosen or remove the lower arm bolts.

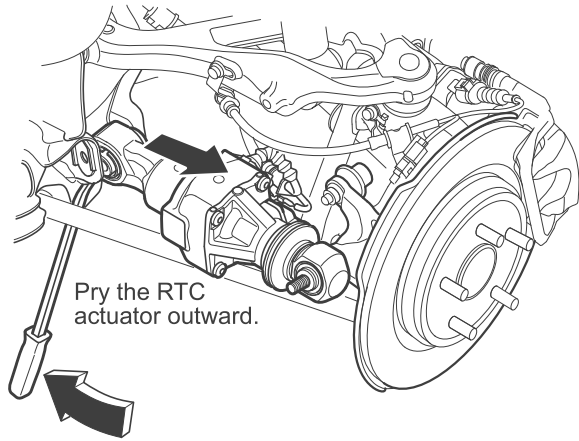

9. Remove the RTC actuator from the vehicle.

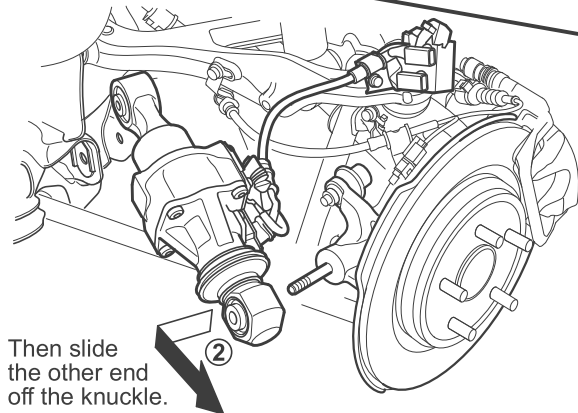
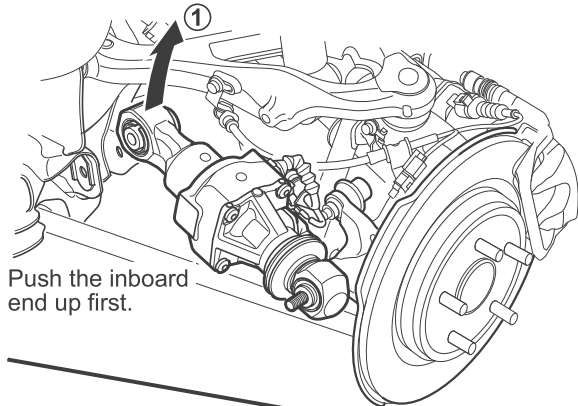

10. Repeat steps 3–9 on the opposite side.

## RTC Actuator Installation

1. Write down the seven-digit number ID of each new RTC actuator for the neutral position wheel memorization.

### RTC ACTUATOR

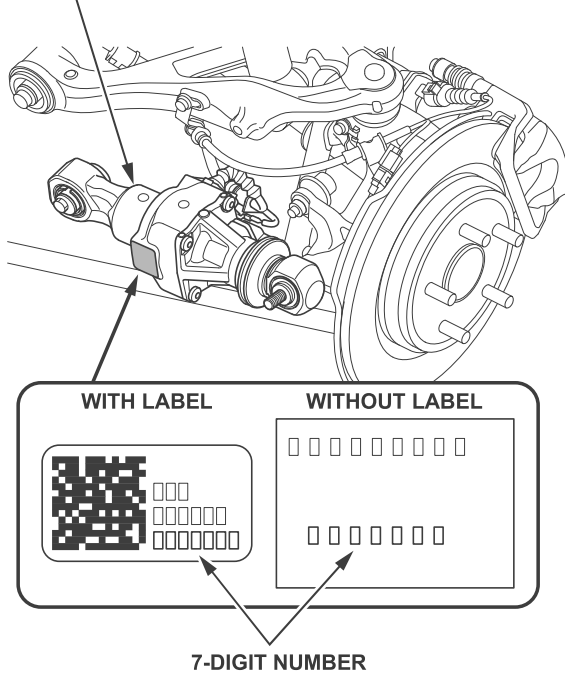

2. Install the new RTC actuator.

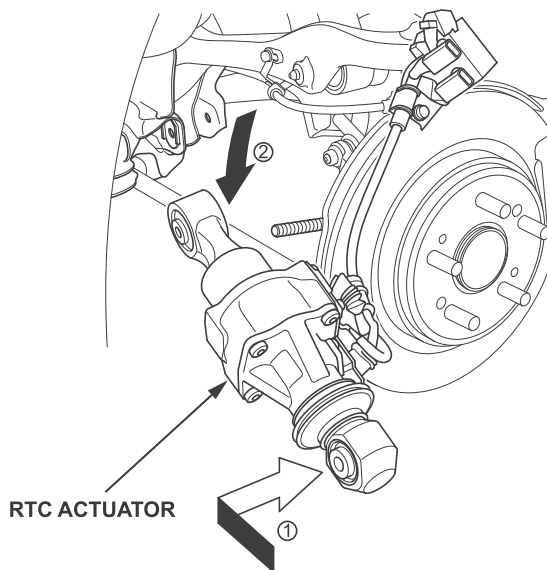

3. Loosely reinstall the original adjusting cam plate using a new inner self-locking nut, and a new adjusting bolt.

NOTE: Align the cam positions of the new adjusting bolt and the adjusting cam plate with the marked positions on the frame.

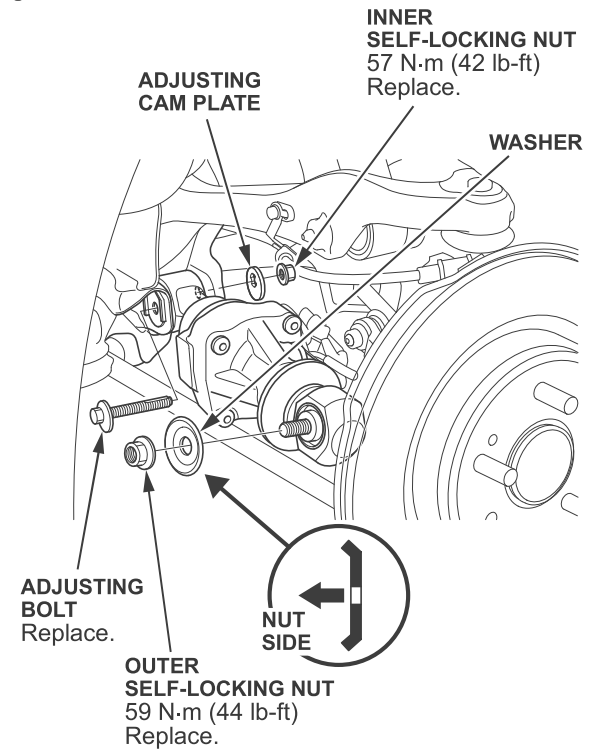

4. Loosely install the new outer self-locking nut and the original washer.
5. Install the new actuator harness bracket mounting bolt and torque it to **22 N·m (16 lb-ft)**, then connect the connectors.

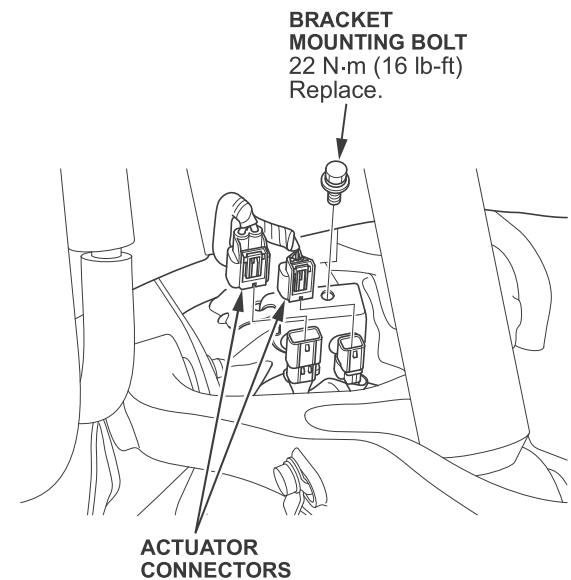

6. Tighten the actuator nuts and bolts until they are snug.
7. Repeat steps 2–6 on the opposite side.
8. Install both rear wheels.
9. Under vehicle load, torque both RTC actuator inner nuts to **57 N•m (42 lb-ft)**.
10. Under vehicle load, torque both RTC actuator outer nuts to **59 N•m (44 lb-ft)**.
11. Connect the HDS to the vehicle and do the neutral position wheel memorization.
12. Select **Precision all wheel steer, Replacement, Continue, Actuator, Right or Left**. Then, enter the seven-digit number ID that you wrote down in step 1 under RTC Actuator installation.
13. Do a wheel alignment.