

July 18, 2017

07047 Version 3

Safety Recall: 2017 MDX Hybrid Fuel Feed and Purge Hose Mis-Installation

Supersedes 17-029, dated June 30, 2017 to revise the information highlighted in **yellow**

AFFECTED VEHICLES

Year	Model	Trim	VIN Range
2017	MDX Hybrid	ALL	Check the iN VIN status for eligibility

REVISION SUMMARY

Added step 10, Vehicle Emissions Recall – Proof of Correction certificate.

BACKGROUND

During vehicle assembly, the factory may have routed the purge and fuel feed hose incorrectly.

CUSTOMER NOTIFICATION

Owners of affected vehicles will be sent a notification of this campaign.

Do an iN VIN status inquiry to make sure the vehicle is shown as eligible.

Some vehicles affected by this campaign may be in your new or used vehicle inventory. These vehicles must be repaired before they are sold.

Failure to repair a vehicle subject to a recall or campaign may subject your dealership to claims or lawsuits from the customer or anyone else harmed as a result of such failure. To see if a vehicle in inventory is affected by this safety recall, do a VIN status inquiry before selling it.

CORRECTIVE ACTION

Inspect the vehicle on the service drive. If the purge and fuel feed hose is misrouted, replace the hoses and route them correctly.

PARTS INFORMATION

NOTE: A disconnected quick connect fitting can be reused, but the retainer on the mating line cannot be reused once it has been removed from the line. Replace the retainer only if needed.

Part Name	Part Number	Quantity
Fuel Feed Hose	16720-5J6-A12	1
Fuel Purge Hose	17717-TRX-A01	1
Quick Connect Fuel Line Retainer (if needed)	17711-S0X-931	1

CLIENT INFORMATION: The information in this bulletin is intended for use only by skilled technicians who have the proper tools, equipment, and training to correctly and safely maintain your vehicle. These procedures should not be attempted by "do-it-yourselfers," and you should not assume this bulletin applies to your vehicle, or that your vehicle has the condition described. To determine whether this information applies, contact an authorized Acura automobile dealer.

WARRANTY CLAIM INFORMATION

The normal warranty applies.

Operation Number	Description	Flat Rate Time	Defect Code	Symptom Code	Template ID	Failed Part Number
3105H6	Inspect the routing of the purge and fuel feed hose.	0.2 hr	6FH00	KF800	17-029N	17717-TRX-A01

3105H6	Inspect the routing of the purge and fuel feed hose.	0.2 hr	6FH00	KF800	17-029P	17717-TRX-A01
A	Replace the purge and fuel feed hose.	0.5 hr				

Skill Level: Repair Technician

INSPECTION PROCEDURE

NOTE: This inspection can be done on the service drive.

1. Open the hood and remove the engine cover.
2. Check if the purge and fuel feed hose is routed **underneath** the breather pipe and not above it.

 **GOOD**

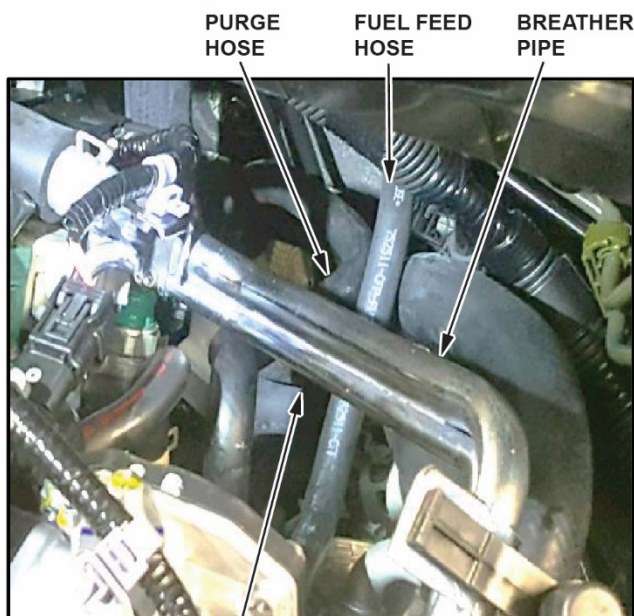

Good condition: Fuel feed hose and purge hose routed underneath the breather pipe.

 **NO GOOD**



No good condition: Fuel feed hose and purge hose routed over the breather pipe.

Is the fuel feed hose and purge hose routed underneath the breather pipe?

Yes – The vehicle is okay, install the engine cover.

No – Go to REPAIR PROCEDURE.

REPAIR PROCEDURE

1. Remove the engine cover.
2. Disconnect and remove the purge hose.

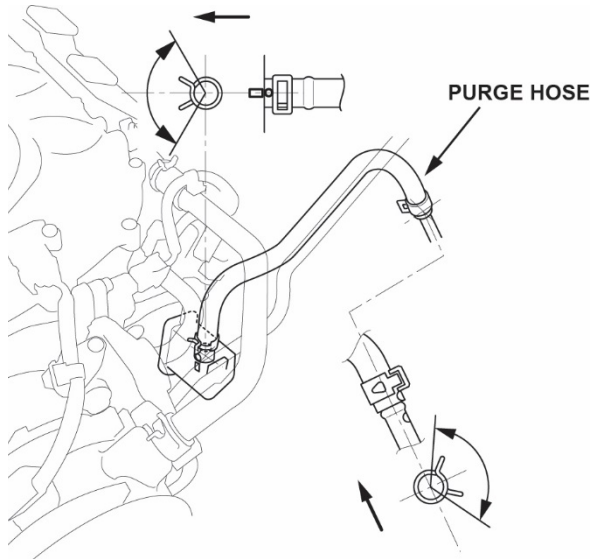

3. Relieve the fuel pressure using the i-HDS.
4. Remove the fuel hose cover.
5. Remove the quick connect fitting cover on the frame side, then disconnect the quick connect fuel line.

NOTE: A disconnected quick connect fitting can be reused, but the retainer on the mating line cannot be reused once it has been removed from the line. Replace the retainer only if needed.

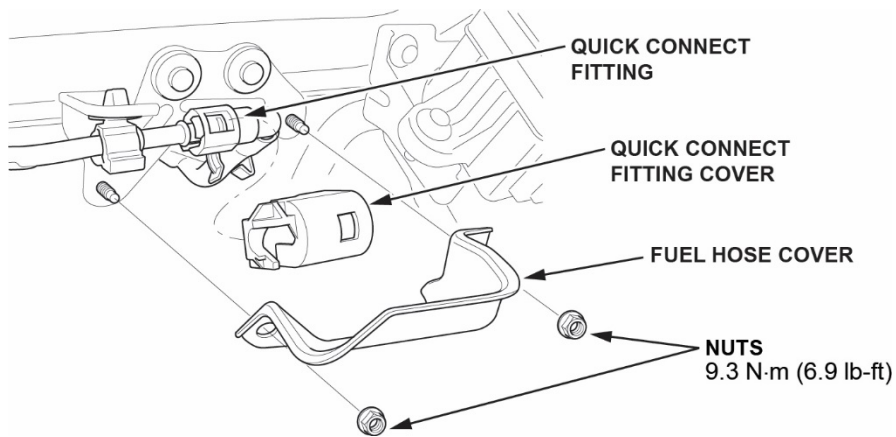

- Remove the fuel feed hose quick connect fitting cover on the engine side, then disconnect the fuel line.

NOTE: A disconnected quick connect fitting can be reused, but the retainer on the mating line cannot be reused once it has been removed from the line. Replace the retainer only if needed.

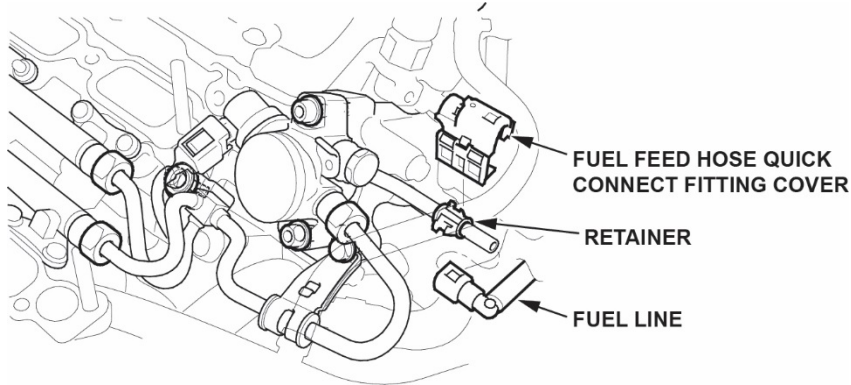

- Install the new purge and fuel hoses in reverse order of removal. Make sure the hoses are routed **underneath** the breather pipe.
- Turn the vehicle to the ON mode (but do not start the engine). The fuel pump runs for about 2 seconds, and fuel pressure rises. Repeat this two or three times, then make sure there are no fuel leaks.
- Install the engine cover.

NOTE: Make sure all the grommets are set.

- For California residents only:** Fill out a Vehicle Emissions Recall – Proof of Correction certificate, and use **KF8** as the recall number. Give the certificate to your customer, and advise him or her to keep it as proof that the recall was completed. Your customer will need to submit this certificate to the DMV only if the DMV requests it. If you need more certificates, use reorder number Y0657.

Vehicle Emission Recall - Proof of Correction				
License Number	Make	Year Model	Body Type	Vehicle Identification Number
Manufacturer			Recall Number KF8	
The above described vehicle has been repaired, modified and/or equipped with new emission control devices to meet applicable California Emission Control Laws.				
Dealer's Name		Address, City, State and Zip		
Date	Dealership's Authorized Signature			
	X			
Return this certificate to DMV only when required - otherwise retain for your records.				

Y0657 ACL 24832 (0212)

END