

October 15, 2020

Version 2

2021 RDX: TQI and New Model Service Information

Supersedes 20-023, dated June 26, 2020, to revise the information highlighted in yellow.

AFFECTED VEHICLES

Year	Model	Trim Level
2021	RDX (2WD, AWD)	Technology Package
		A-Spec Package
		Advance Package
		PMC Edition

REVISION SUMMARY

- Under AFFECTED VEHICLES, PMC Edition was added.
- CLAIM INFORMATION, additional time was added for the PMC Edition.
- NEW MODEL SERVICE INFORMATION was added to include paint care for the PMC Edition.

CLIENT INFORMATION: The information in this bulletin is intended for use only by skilled technicians who have the proper tools, equipment, and training to correctly and safely maintain your vehicle. These procedures should not be attempted by “do-it-yourselfers,” and you should not assume this bulletin applies to your vehicle, or that your vehicle has the condition described. To determine whether this information applies, contact an authorized Acura automobile dealer.

INTRODUCTION

This bulletin covers the total quality inspection (TQI) of the 2021 RDX. It includes these procedures:

1. Install the Fuse
2. Check the Battery
3. Remove the Exterior Protective Coatings
4. Remove the Interior Protective Coverings
5. Install the Floor Mats
6. Check Hands Free Access Power Tailgate Operation (Advance Package Only)
7. Install the Body Plugs
8. Install the Engine Peep Hole Body Plug
9. Install the Front License Plate Holder
10. Set the Tire Pressures
11. Do the PCM Idle Learn Procedure
12. Do the CKP-Pattern Learn Procedure
13. Check the Power Seat Adjustments
14. Exit the Anti-Theft Mode
15. Check/Refresh the SiriusXM® Radio Dealer Demo Service (Except Alaska and Hawaii)
16. Check the Instrument Panel Brightness Control
17. Check the Safety and Driver Assistance Indicators
18. Check the Wipers/Washers Operation
19. Check the Panoramic Glass Roof Operation
20. Check Wi-fi Operation

To do a TQI of the navigation system, be sure to complete S/B 20-024, *2021 RDX: TQI of the Navigation System*

This bulletin also includes this new model service information:

1. New Tire Pressure Sensors
2. Paint Care for PMC Edition

CLAIM INFORMATION

Reimbursement Time: 1.4 hours. Add 0.2 for PMC Edition

TQI PROCEDURES

Before Starting

Review these items:

- Perfect Delivery documents, especially the information on battery maintenance and tire pressures
- TQI checklist in the maintenance journal

Make sure you record the TQI on the appropriate pages of the checklist. The TQI is not done until this bulletin and the checklist are both complete. Note on the repair order any repairs or problems that cannot be fixed within a few minutes.

Remove all TQI items from the cargo area, glove box, and cup holders.

Starting the Engine Without the Backup Fuse

To lower parasitic draw, the vehicle comes from the factory with the No. 18 BACKUP (10 A) fuse removed from the under-hood fuse/relay box. With the backup fuse removed, the engine will not start when you apply the brake pedal and press the ENGINE START/STOP button.

To start the engine with the fuse removed, do the following:

1. Make sure the transmission is in Park. Press the ENGINE START/STOP button once. The indicator will blink.



2. Touch the keyless remote to the ENGINE START/STOP button.



The indicator will switch from blinking to steady when communication is complete.



3. Start the engine by pressing the ENGINE START/STOP button while applying the brake pedal. You must start the engine within **10 seconds** of touching the remote to the button.

1. Install the fuse.

To lower battery drain during vehicle shipping, the No. 18 BACKUP (10 A) fuse is removed from the under-hood fuse/relay box and stored in the cup holder. Make sure you turn the ignition to OFF and wait for at least **1 minute** before installing it.

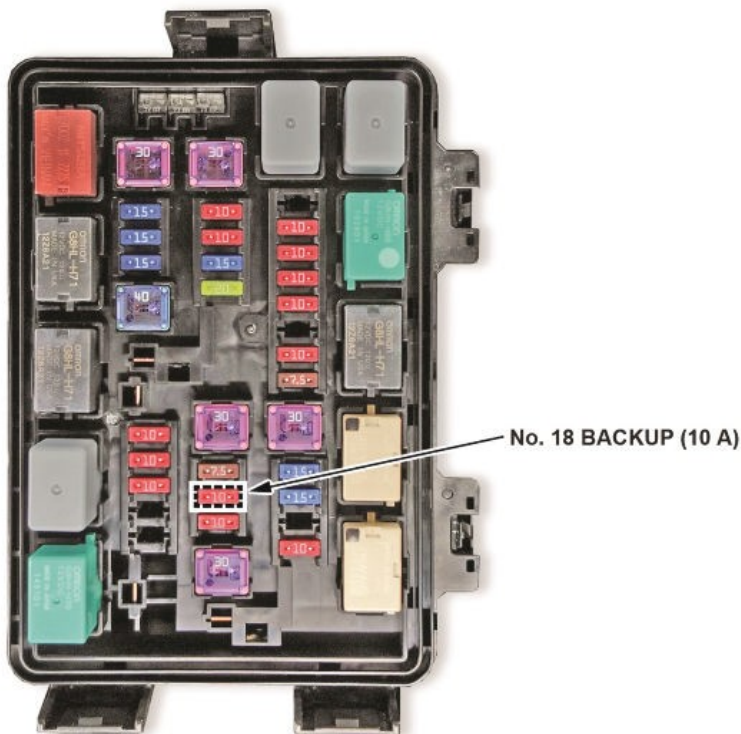

2. Check the battery.

To ensure long battery life and that the client gets a fully charged battery, you must check it at these times:

- When the vehicle first arrives at the dealership
- During the TQI (if done at a later date)
- At regular intervals (if stored)
- Just before vehicle delivery

Test the battery with the ED-18 battery tester using S/B 88-016, *Battery Testing and Replacement*. Make sure the ED-18 has the latest software installed before using it. See S/B 09-027, *ED-18 Battery Tester Update Information*.

Write down the **GOOD BATTERY** 10-digit code in the Before Starting the TQI section. Test the battery again at vehicle delivery, and charge it if needed. Write down the new code in the Final Inspection (At Delivery) section.

Always check the battery cables and terminal tightness when testing the battery.

If the ED-18 does not show **GOOD BATTERY** or shows **GR8 DIAGNOSTIC NEEDED**, you must charge the battery with the GR8 battery diagnostic station. Make sure the GR8 has the latest software installed before using it. See S/B 09-034, *GR8 Battery Diagnostic Station Update Information*.

3. Remove the Exterior Protective Coatings

Vehicle Interior

Carefully remove all of the exterior protective coatings. See S/B 96-009, *Removal of Protective Coatings During TQI*.

4. Remove the Interior Protective Coverings

There are several protective coverings on the interior trim pieces and some areas of the carpet. Carefully remove all interior protective coverings with clean hands to avoid soiling any surfaces.

If any of the interior is dirty, clean it with mild soap or a Acura cleaning product such as the Acura Genuine Interior Car Care Kit (P/N 08700-9311B), Leather & Vinyl Cleaner (P/N 08700-9214), or Carpet Spot Remover (P/N 08700-9215).

If the vehicle has a leather-wrapped steering wheel, remove the protective covering by pulling the top towards you. Do not try removing it by pulling the top away and down from you, or you will damage the cable reel. Also, do not use any cutting tools to remove the covering; you could damage the leather.

Clean real wood surfaces with a mild detergent and a soft, damp cloth. Be sure to wipe off any excess liquid to avoid damaging the wood. Do not use other cleaning agents like household detergents on this wood. These products could damage it.



Clean real wood surfaces with a mild detergent and a soft, damp cloth. Be sure to wipe off any excess liquid to avoid damaging the wood. Do not use other cleaning agents like household detergents on this wood. These products could damage it.

5. Install the Floor Mats

Install the floor mats where they belong. Be sure to place the driver's floor mat eyelets over the anchors in the floor and turn the knobs clockwise to the lock position.

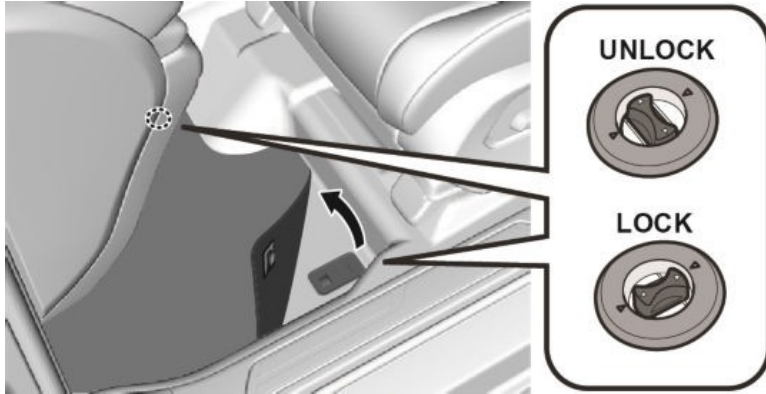

Vehicle Exterior

6. Check Hands Free Access Power Tailgate Operation (Advance Package Only)

To check the hands free access power tailgate operation, make sure you have the keyless remote with you, then kick your foot up under the rear bumper in the target area to activate the hands free access power tailgate control unit/ sensor. With the accessory trailer hitch installed, the target area is only on the driver's side. Make sure you are kicking straight up and straight back (no side-to-side motion). The kick should be smooth and continuous, lasting no more than **1 second** from ground to tailgate to ground.

NOTE

If the tailgate does not immediately open after the first kick, wait at least **5 seconds** before trying a second kick. The hands free access system may not respond if it detects multiple kicks in a short period.

Without Trailer Hitch:

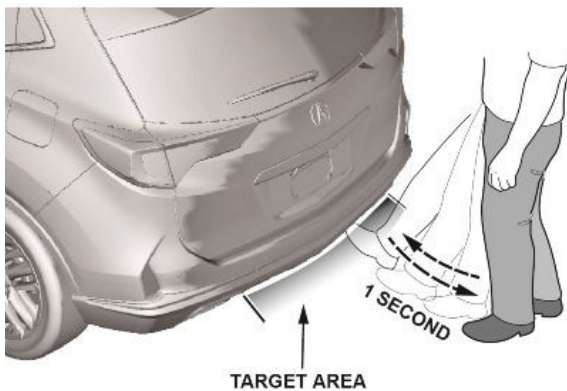

With Trailer Hitch:

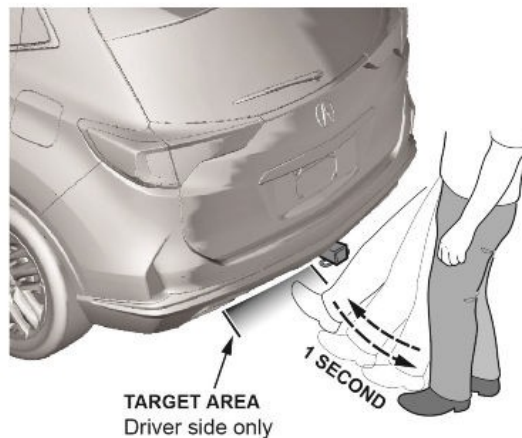

Under Vehicle (Vehicle Raised to Full Height)

7. Install the Body Plugs

Install the body plugs as shown.

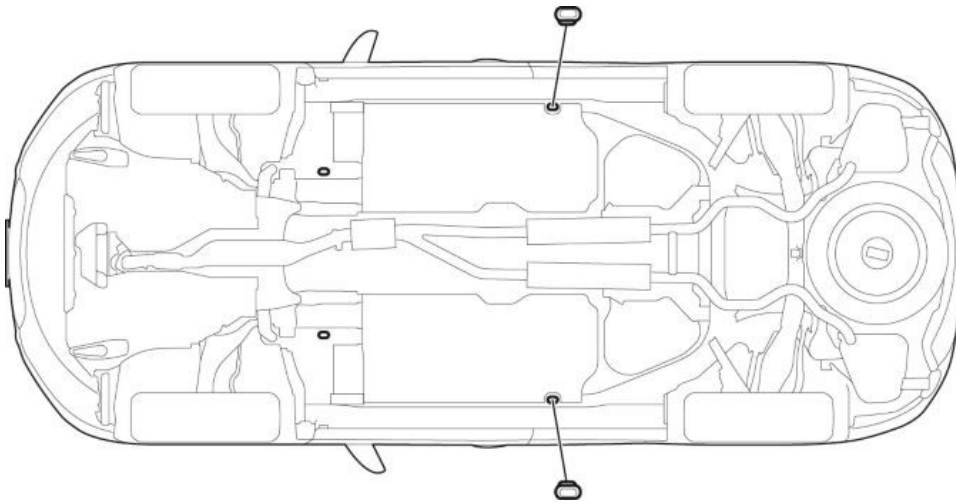

Once installed, the body plugs may not sit flush with the body. This is normal.

VEHICLE EXTERIOR (VEHICLE LOWERED TO HALF HEIGHT)

8. Install the Engine Peep Hole Body Plug

Open the hood, and install the engine peep hole body plug as shown.



9. Install the Front License Plate Holder

If state regulations require the use of a front license plate, install the front license plate holder as shown using the longer rounded Phillips-head screws.

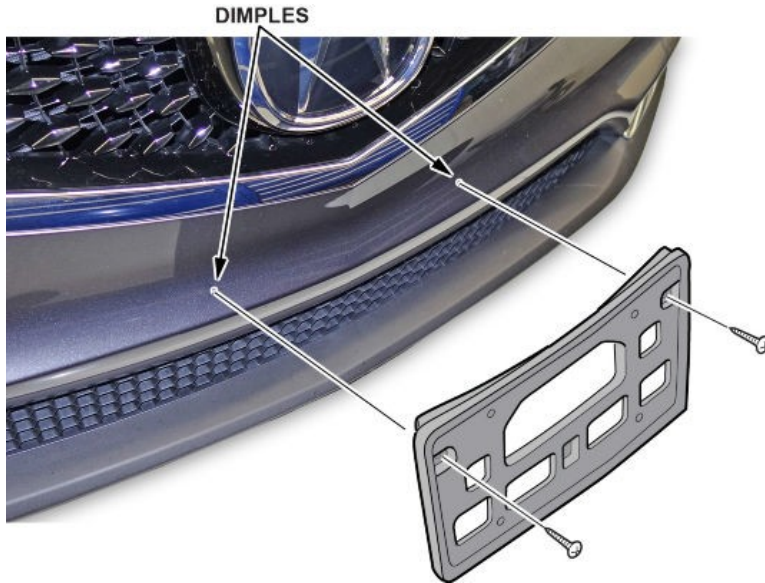

Four Hex-head screws are used to attach the front plate to the holder. The remaining four rounded Phillips-head screws are used to attach the rear license plate.

Vehicle Exterior (Vehicle Lowered to Ground)

10. Set the Tire Pressures

To prevent flat spots during vehicle shipping and storage, the tires are inflated to over **40 psi**. If the vehicle is going into dealer storage, leave the tire pressures at **40 psi** until it is sold. When the vehicle is moved to the sales lot or is sold, adjust the tire pressures.

1. Turn the ignition to ON.
2. Set the pressure in each tire to the recommended value listed on the driver's doorjamb label, and check it with a hand-held gauge. If you are in a cold climate region, make sure the tires are at the same temperature as the outside air before adjusting the pressures, otherwise the Low Tire Pressure/TPMS indicator may come on in cold weather.
3. Test-drive the vehicle for at least **1 minute** above **22 mph**. If the MID does not show the tire pressures, make sure you completed the test-drive as specified.

Be sure to check the pressure in the spare tire (if equipped).

NOTES

Some trim levels do not have a spare tire; instead, they come with a tire repair kit stored under the cargo floor. For those trim levels, an optional spare tire wheel kit can be ordered separately

When checking the pressure in the spare tire, make sure to lower the tire all the way to the ground. Set the pressure according to the driver's doorjamb label. Before raising the spare tire back into the vehicle, make sure the spare tire bracket is centered. With it centered, the tire will be close to level as it is raised back into the vehicle. Failure to center the bracket may result in a failure of the bracket cable over time. Do not use power tools to raise the spare tire as this may damage the bracket cable.

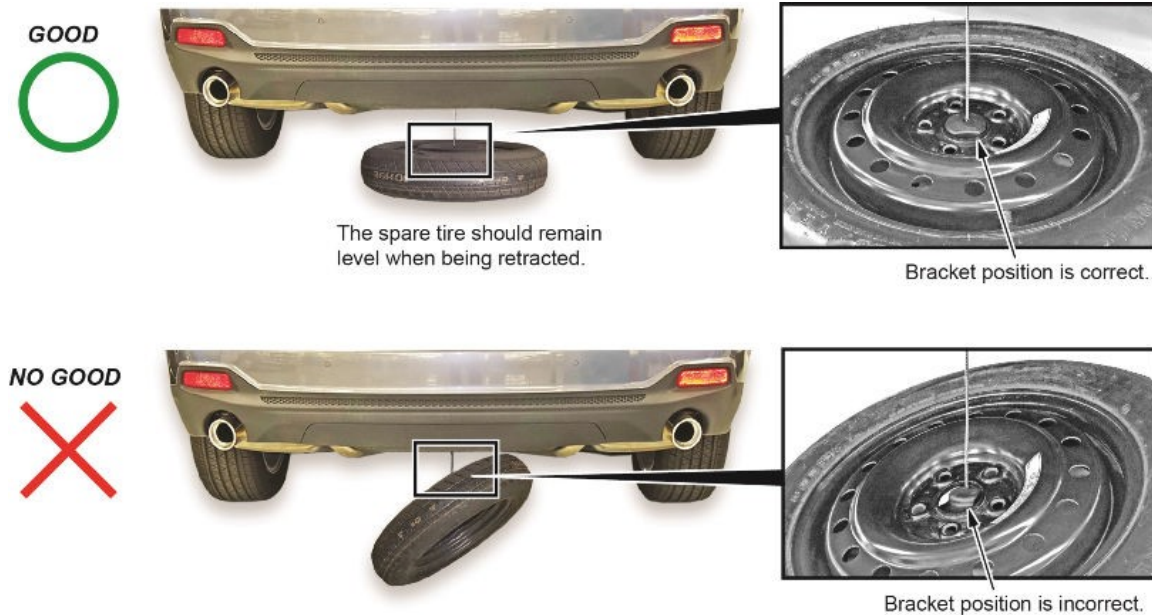

NOTE

After checking the spare tire pressure, make sure all three cargo floor lid clips are properly engaged and the floor lid is properly installed. Failure to secure all three clips could result in a rattle.

Under-Hood (Engine Idling)

11. Do the PCM Idle Learn Procedure

To ensure a steady engine idle, do the PCM idle learn procedure as follows after installing the fuse (see 1. Install the Fuse).

NOTES

- The PCM idle learn procedure must also be done after updating or replacing the PCM. It does not need to be done after clearing DTCs.
- Failure to do this procedure correctly may result in poor shift quality.
- Start the engine with the transmission in Park, and make sure all electrical items (A/C, audio unit, rear window defogger, lights, etc.) are turned off.
- Wait for the engine to reach operating temperature (the cooling fans cycle twice).
- Let the engine idle for **10 minutes** with the throttle fully closed.
- Turn the ignition to OFF.

12. Do the CKP-Pattern Learn Procedure

To ensure proper engine operation, do the CKP-pattern learn procedure after doing the PCM idle learn procedure. Do it on a level road during your TQI test-drive.

NOTES

- Make sure all electrical loads (A/C, heated seats, audio unit, etc.) are turned off before doing this procedure.
- Failure to do this procedure correctly may result in poor driveability along with misfire DTCs.
- While driving on a level road, decelerate from **2,500 rpm to 1,000 rpm** with the transmission in 2nd gear and the throttle fully closed. Repeat this three times.

Vehicle Interior

13. Check the Power Seat Adjustments

- Check the power seat slide, height, and tilt adjustments.
- Check the 4-way power lumbar adjustment.

NOTE

You can move the lumbar up/down and expand it outward/retract it inward. Controls for lumbar adjustment are next to the seat-back tilt adjustment on the bottom outer sides of the seat.

POWER SEAT ADJUSTMENT
MODE SELECTOR



MODE
SELECTOR ADJUSTMENT
SWITCH

SEAT ADJUSTMENT INFORMATION ON THE
AUDIO/INFORMATION SCREEN

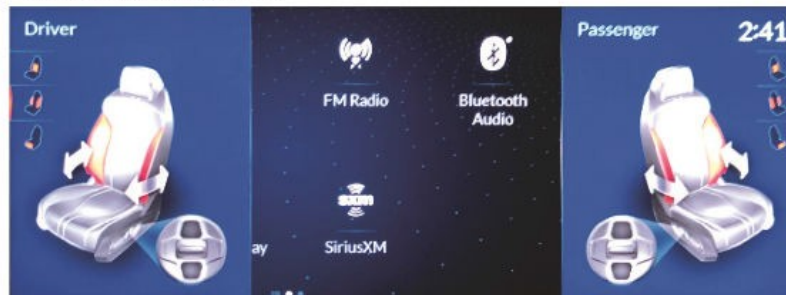

- Check the side bolster adjustment (if equipped).
- Check the power thigh extension (if equipped).

14. Exit the Anti-Theft Mode

The vehicle ships in anti-theft mode. To exit this mode, do this:

1. Start the engine.
2. Wait for the message below to appear on the display. If needed, press and hold the Power/VOL knob to turn on the audio/navigation unit.

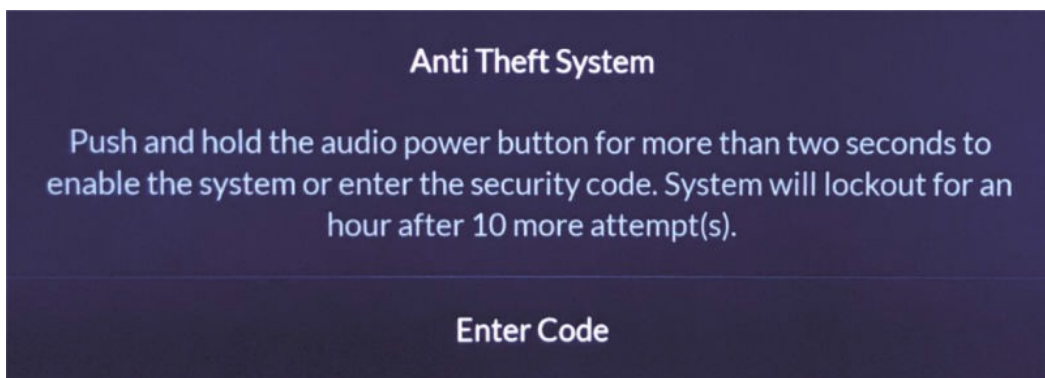

3. Press and hold the Power/VOL knob for about **2 seconds**. This lets the PCM check that the vehicle's VIN matches the one saved in the unit. You will hear a long beep when the unit exits the anti-theft mode. Release the knob.

15. Check/Refresh the SiriusXM® Radio Dealer Demo Service (Except Alaska and Hawaii)

The audio system comes from the factory activated with the SiriusXM® Radio dealer demo service. Once you install the fuse (see 1. Install the Fuse), the system receives the full range of available channels. You can see a full list of available channels at www.siriusxm.com.

While watching the display, tune to several channels within the full channel lineup. The dealer demo service is activated when you can tune to all of the channels.

16. Check the Instrument Panel Brightness Control

To check the instrument panel brightness control, turn on the headlights and adjust the panel brightness using the buttons under the panel. The panel cannot be dimmed when the headlight settings are on Auto and it is daylight outside.



INSTRUMENT
BRIGHTNESS CONTROL

17. Check the Safety and Driver Assistance Indicators

When you first turn the ignition to ON, these indicators should come on for a few seconds and then go off.

- ACC (Adaptive Cruise Control)
- LKAS (Lane Keeping Assist System)
- Road Departure Mitigation
- CMBS (Collision Mitigation Braking System™)

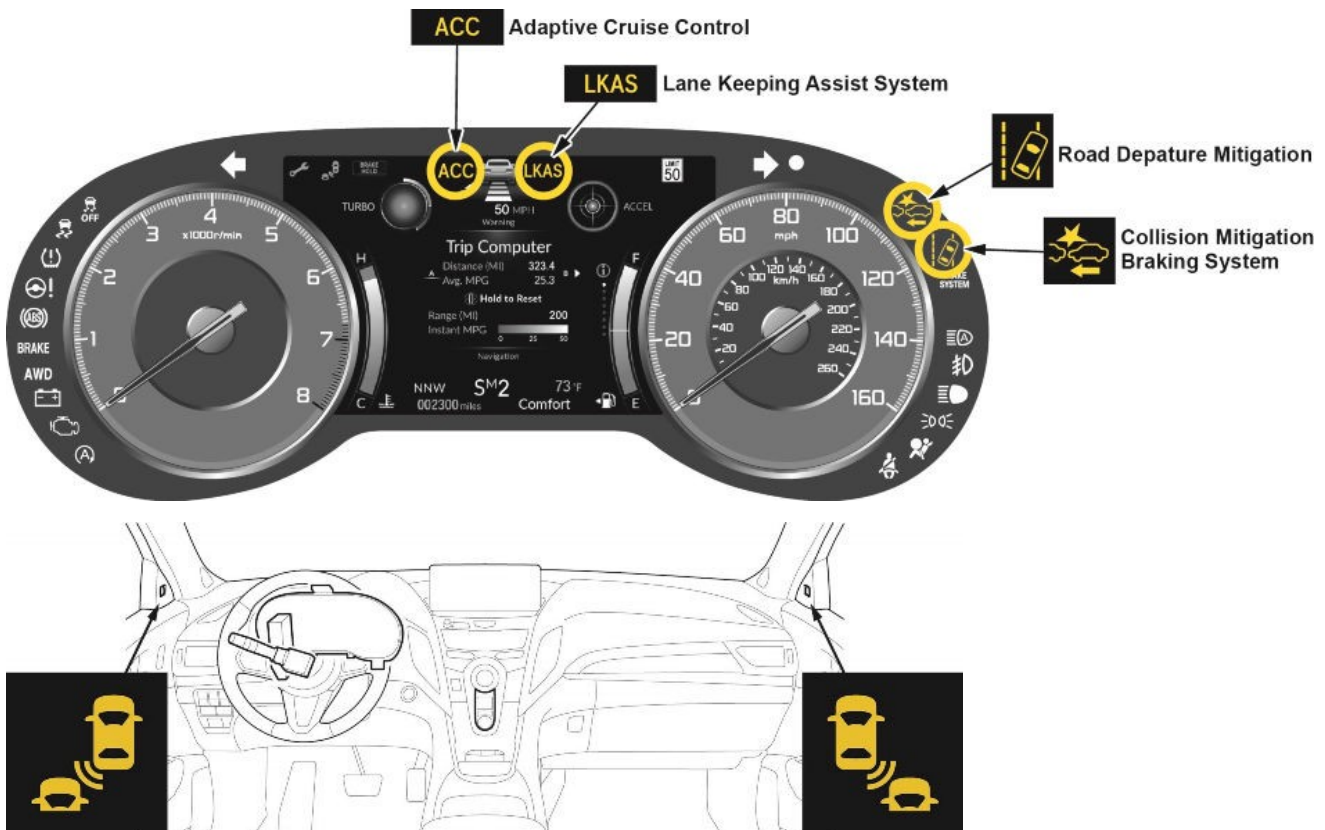

18. Check the Wipers/Washers Operation

Check operation of the windshield and rear window wipers.

Check operation of the windshield and rear window washers as well as the rear camera washer (Advance Package only).

NOTE

The rear camera washer comes on at the same time as the rear window washer.



19. Check the Panoramic Glass Roof Operation

Make sure the panoramic glass roof and shade one-touch feature work properly.

1. Firmly pull the glass roof open/close and tilt switch backward. The glass roof should open to about $\frac{3}{4}$ of its max position.
2. Firmly push up on the switch, and release it. The glass roof will tilt up, and the shade will open a small amount.
3. Firmly pull the glass roof shade open/close switch backward. The shade should open to its full position.



20. Check Wi-fi Operation

1. Press the Home button, then select **Settings, Connections, and Wi-Fi**.
2. Make sure the vehicle is in **Network** mode. If needed, select **Change Mode** to switch to **Network**, then select **Save**.
3. Look for wireless access points under **Available Networks**. When wireless access points are displayed, the Wi-Fi is working.

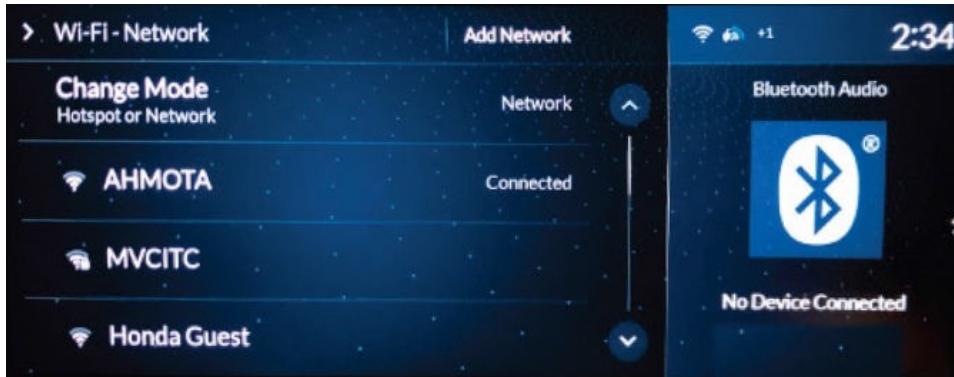

NEW MODEL SERVICE INFORMATION

1. New Tire Pressure Sensors

Beginning with the 2021 model year RDX, Base and Tech trim levels will come with rubber valve stem tire pressure sensors. Advanced and A-Spec trim levels will keep their metal valve stem tire pressure sensors.

2. Paint Care for PMC Edition

Never run the PMC Edition through a conveyor-style car wash or use any type of motorized cleaning device that could damage the vehicle and the paint.

Always wash the vehicle by hand with a mild car wash detergent and plenty of fresh water.

Review the job aid [RDX PMC Edition Exterior Paint Handling Information](#). You will find useful tips about caring for this special edition paint.

END