

Audio System

Circuit Diagram

ELS audio system

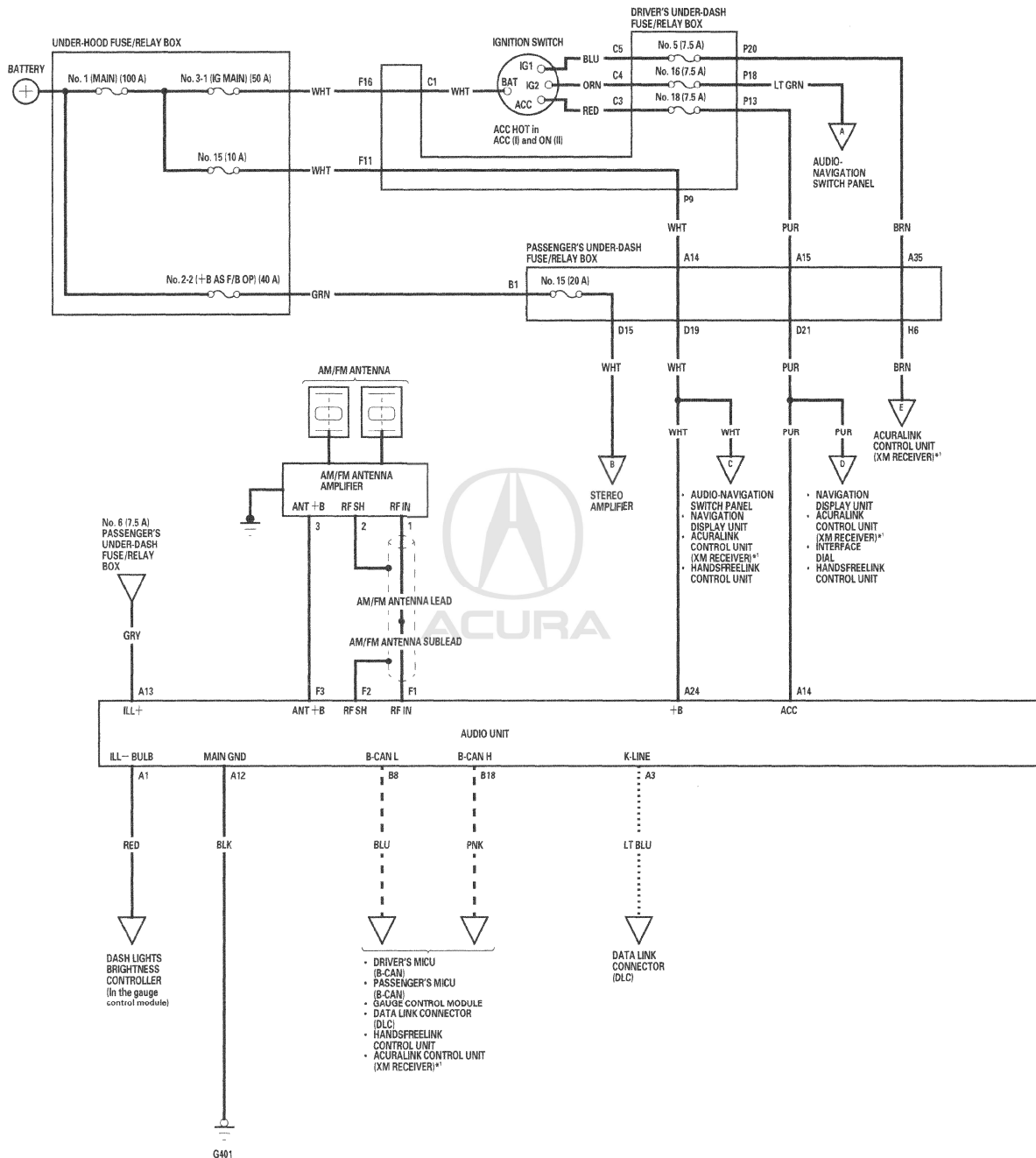



*1: USA models
 *2: The shielded wires have a heat-shrink tube insulating the outside of the wire. The color of the insulating tube, typically black or dark gray, may not match the color of the wire shown on the circuit diagram.

--- CAN line
 Other communication line
 - - - - - Shielding

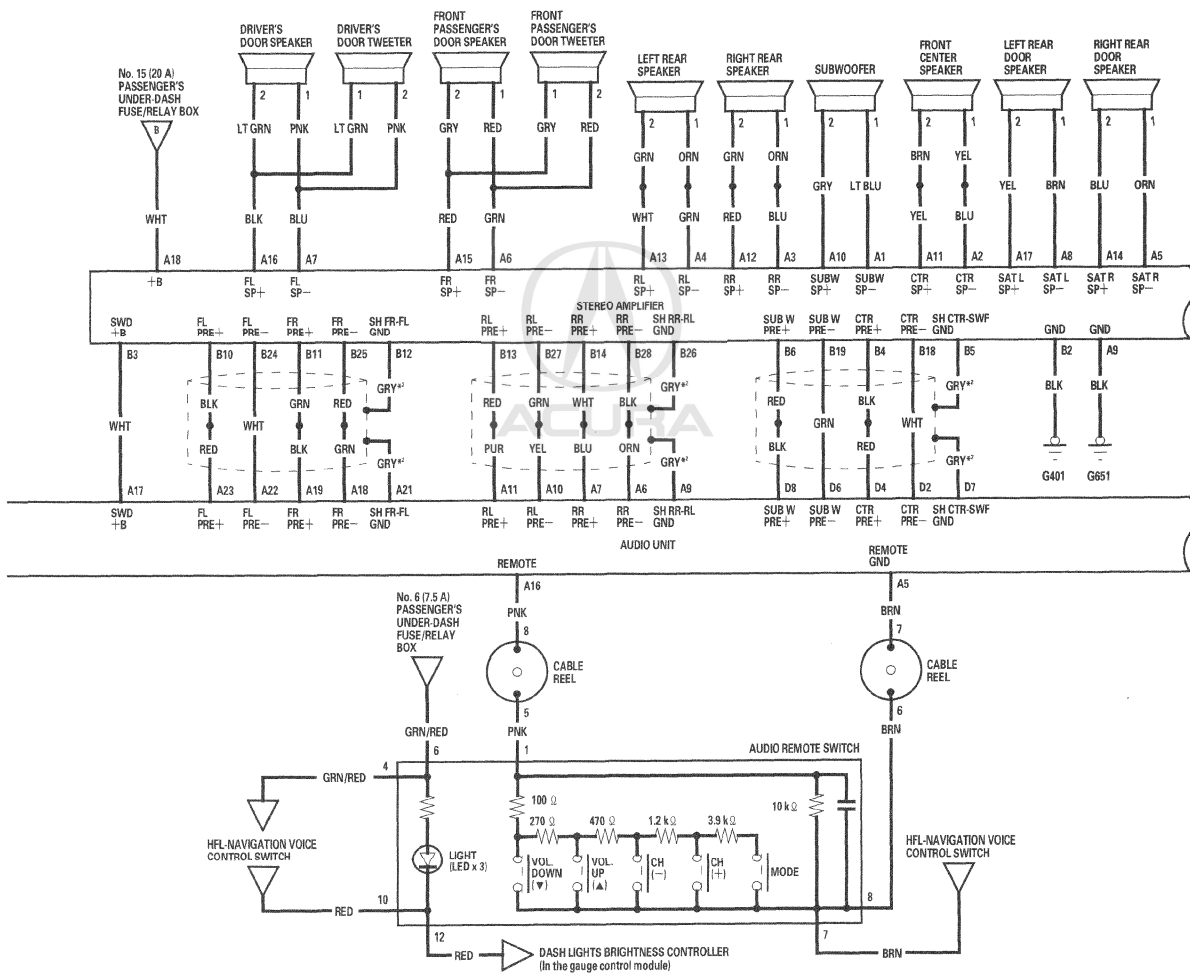

(cont'd)

Audio System

Circuit Diagram (cont'd)

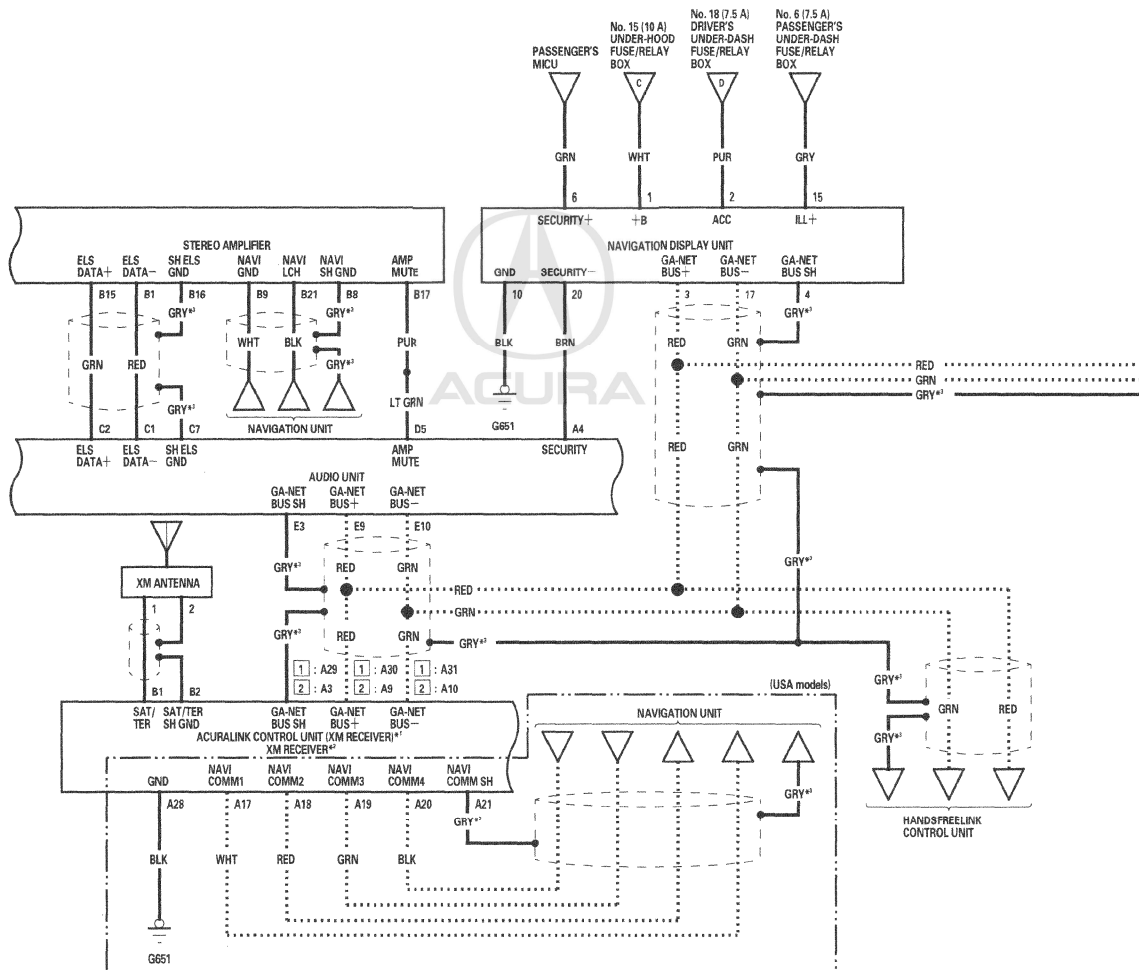



*1: USA models
 *2: Canada models
 *3: The shielded wires have a heat-shrink tube insulating the outside of the wire. The color of the insulating tube, typically black or dark gray, may not match the color of the wire shown on the circuit diagram.

1: USA models
 2: Canada models

--- : CAN line
 : Other communication line
 - - - - : Shielding

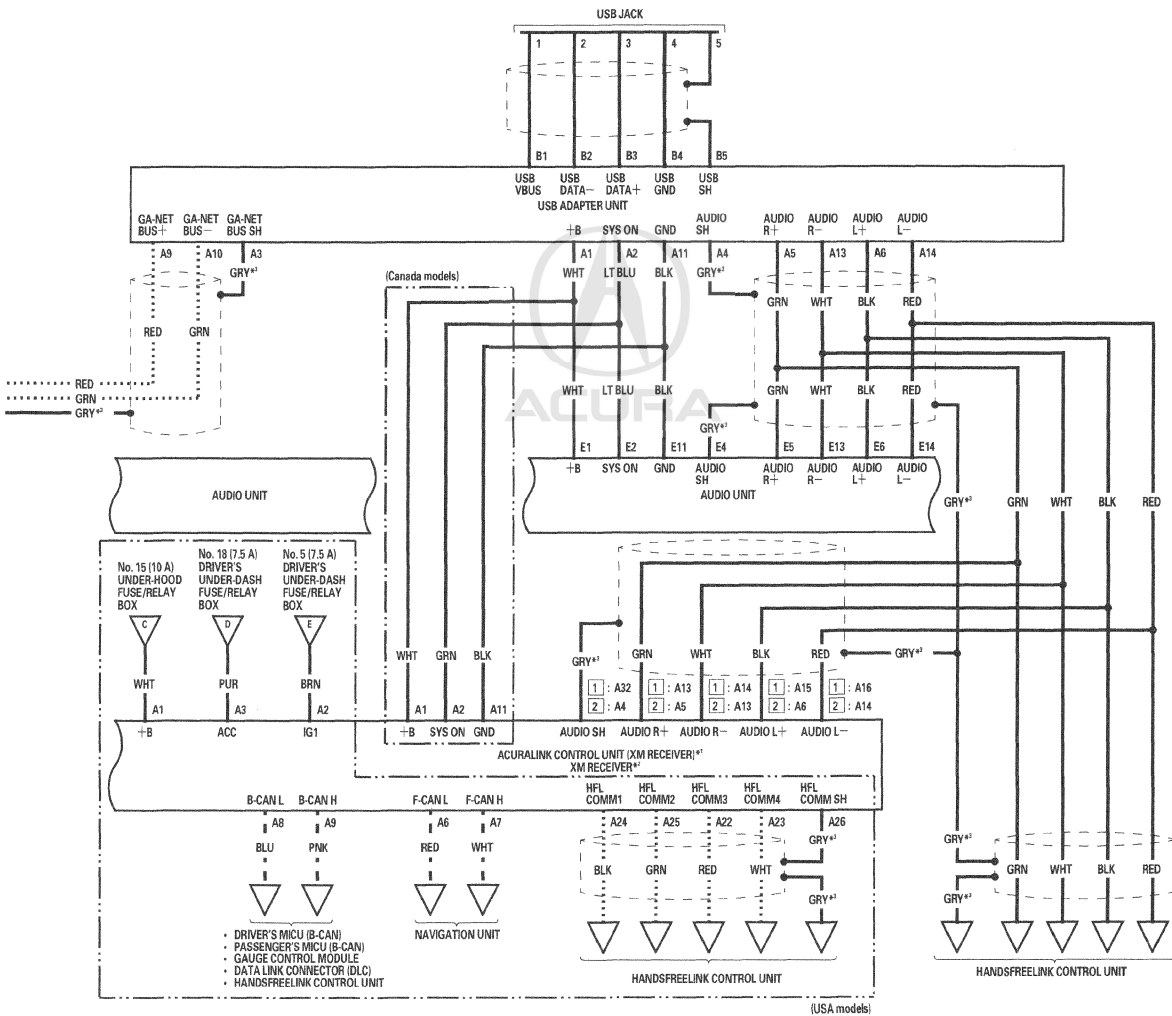

(cont'd)

Audio System

Circuit Diagram (cont'd)

*: The shielded wires have a heat-shrink tube insulating the outside of the wire. The color of the insulating tube, typically black or dark gray, may not match the color of the wire shown on the circuit diagram.

.....: Other communication line
 - - - - -: Shielding

