

A/T Gear Position Indicator

Transmission Range Switch Replacement

1. Raise the front of the vehicle, and make sure it is securely supported (see page 1-11).
2. Set the parking brake, and block both rear wheels securely.
3. Shift to the **N** position.
4. Remove the transmission range switch connector (A) from the connector bracket (B), then disconnect the connector.

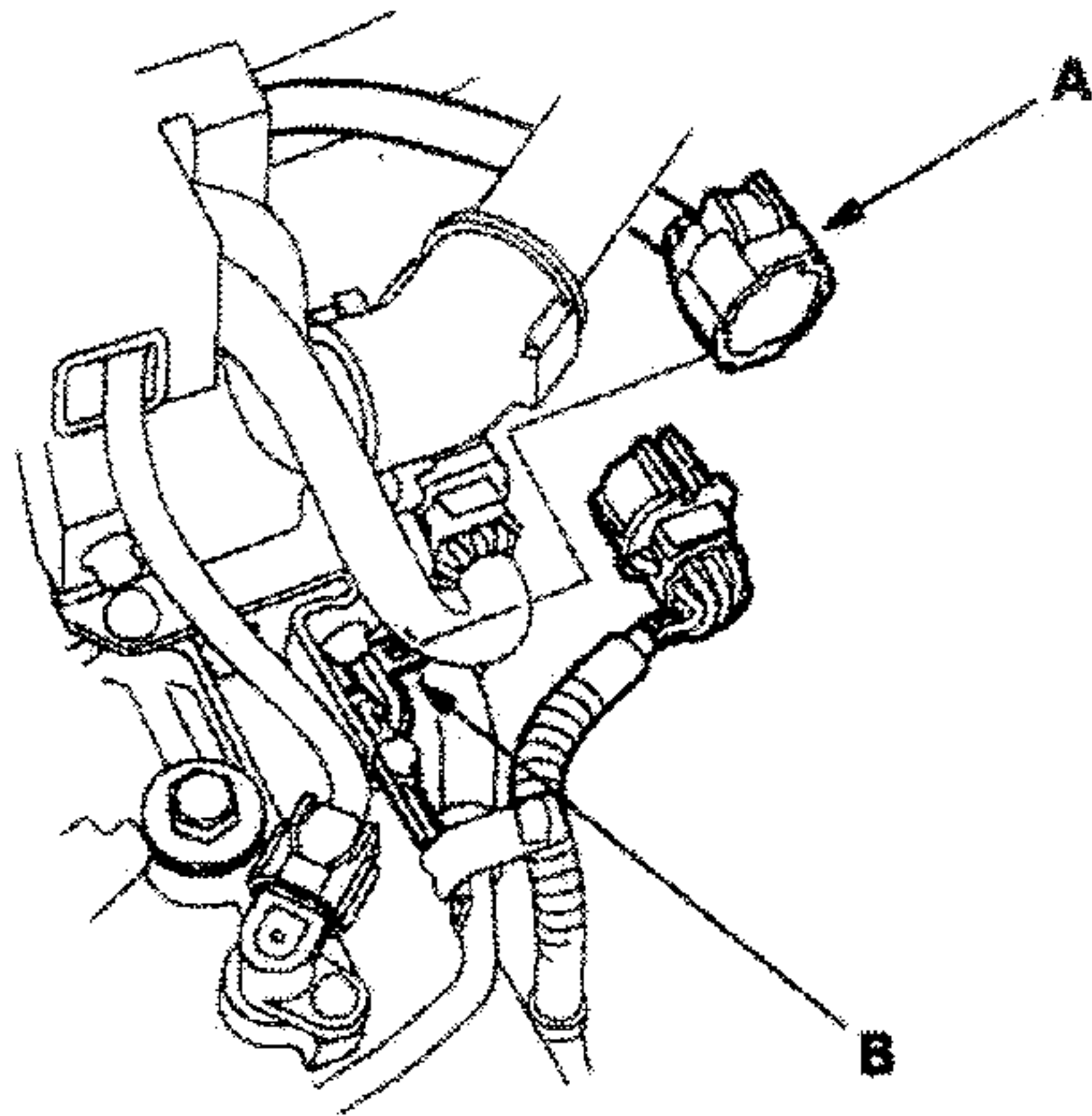

5. Remove the clamp from the harness clamp bracket on the transmission housing, and remove the harness clamp (A) from the end cover (B).

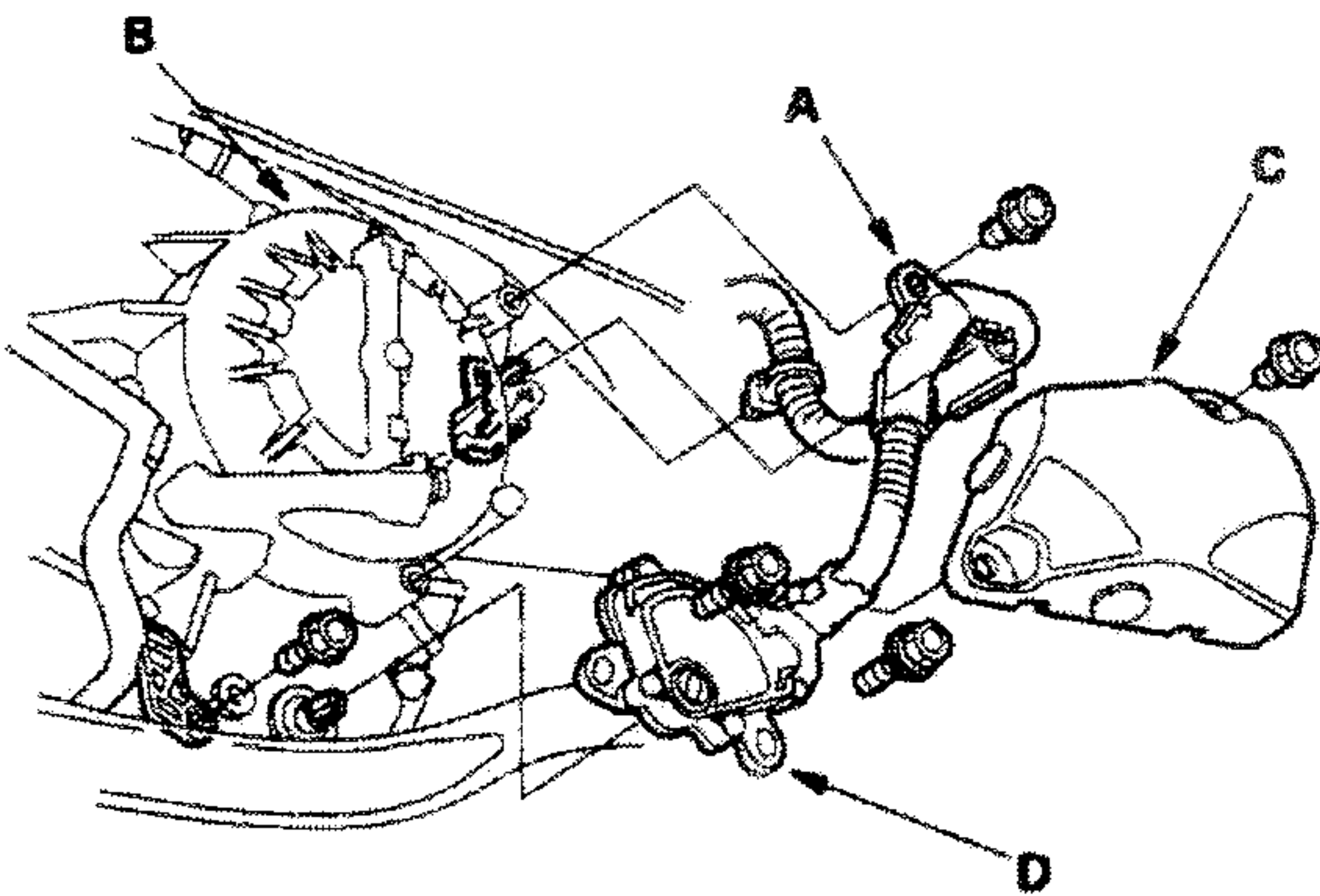

6. Remove the transmission range switch cover (C), then remove the transmission range switch (D) from the end cover.

7. Set the transmission range switch to the **N** position.

NOTE: The transmission range switch clicks in the **N** position.

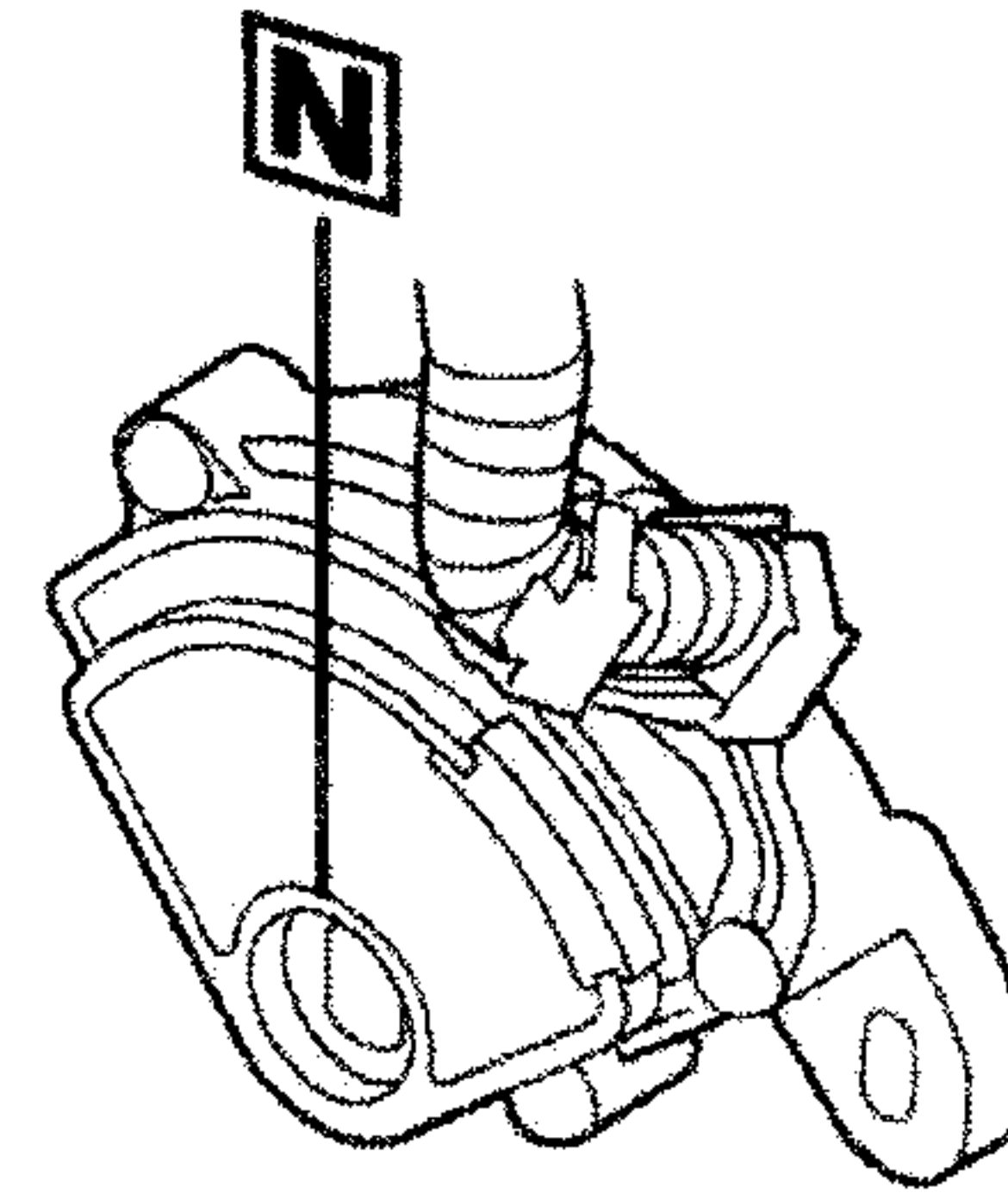

8. Set the control shaft to the **N** position.

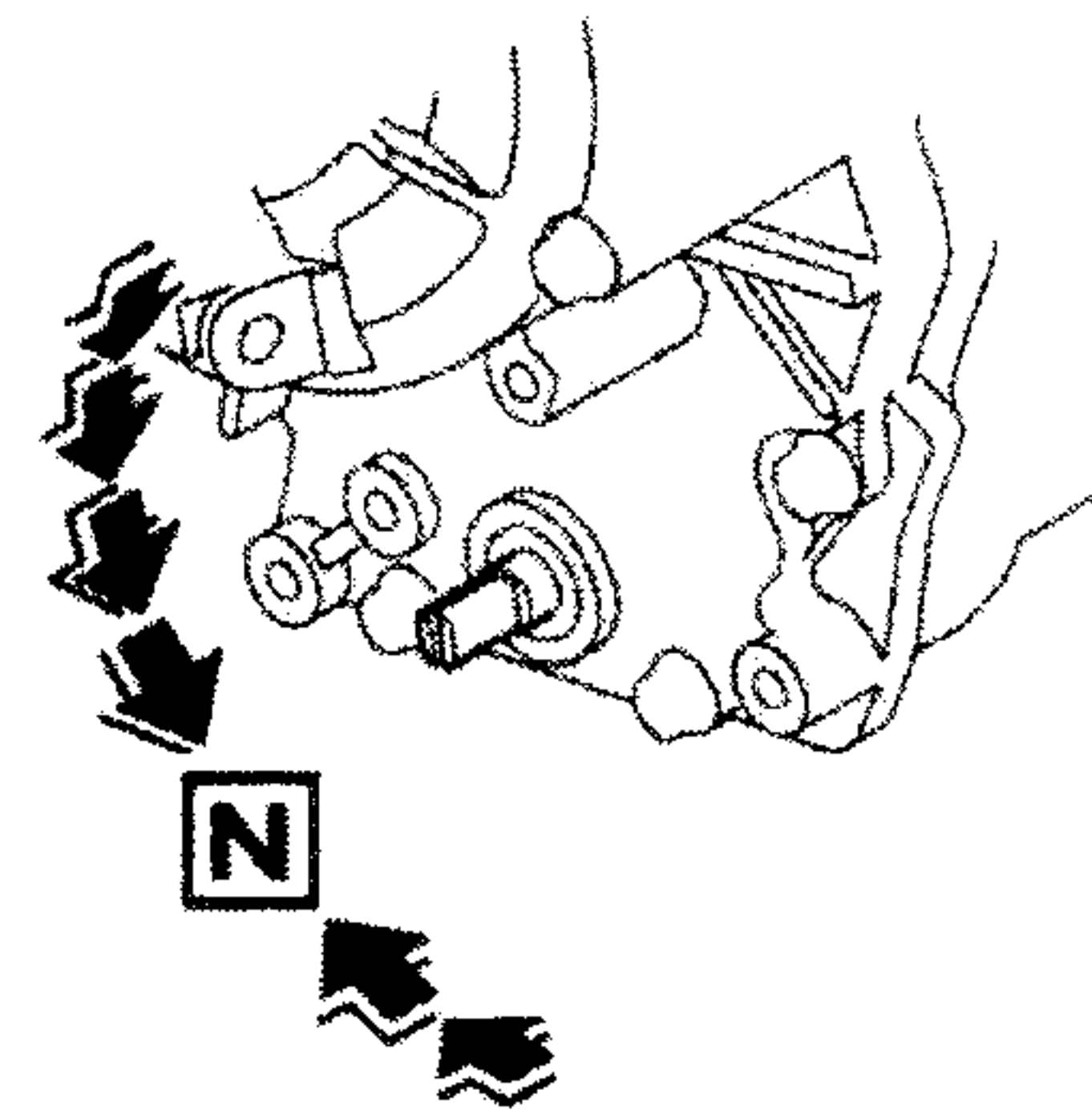



9. Install the transmission range switch (A) on the control shaft (B), then secure it with the bolts.

NOTE: Take care not to move the transmission range switch when tightening the bolts.

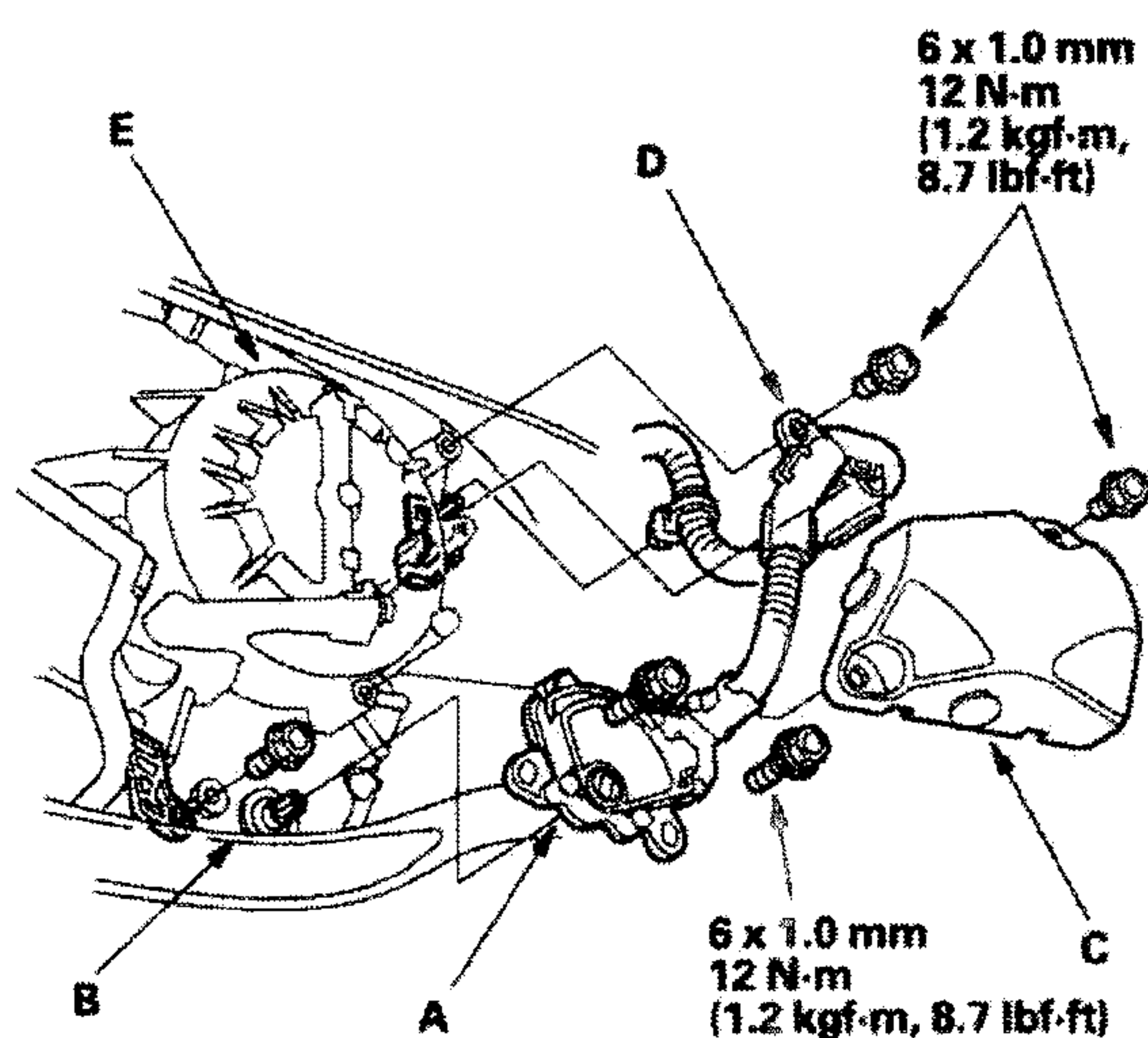

10. Install the transmission range switch cover (C), and the harness clamp (D) on the end cover (E).

11. Connect the transmission range switch connector (A), then install it on the connector bracket (B).

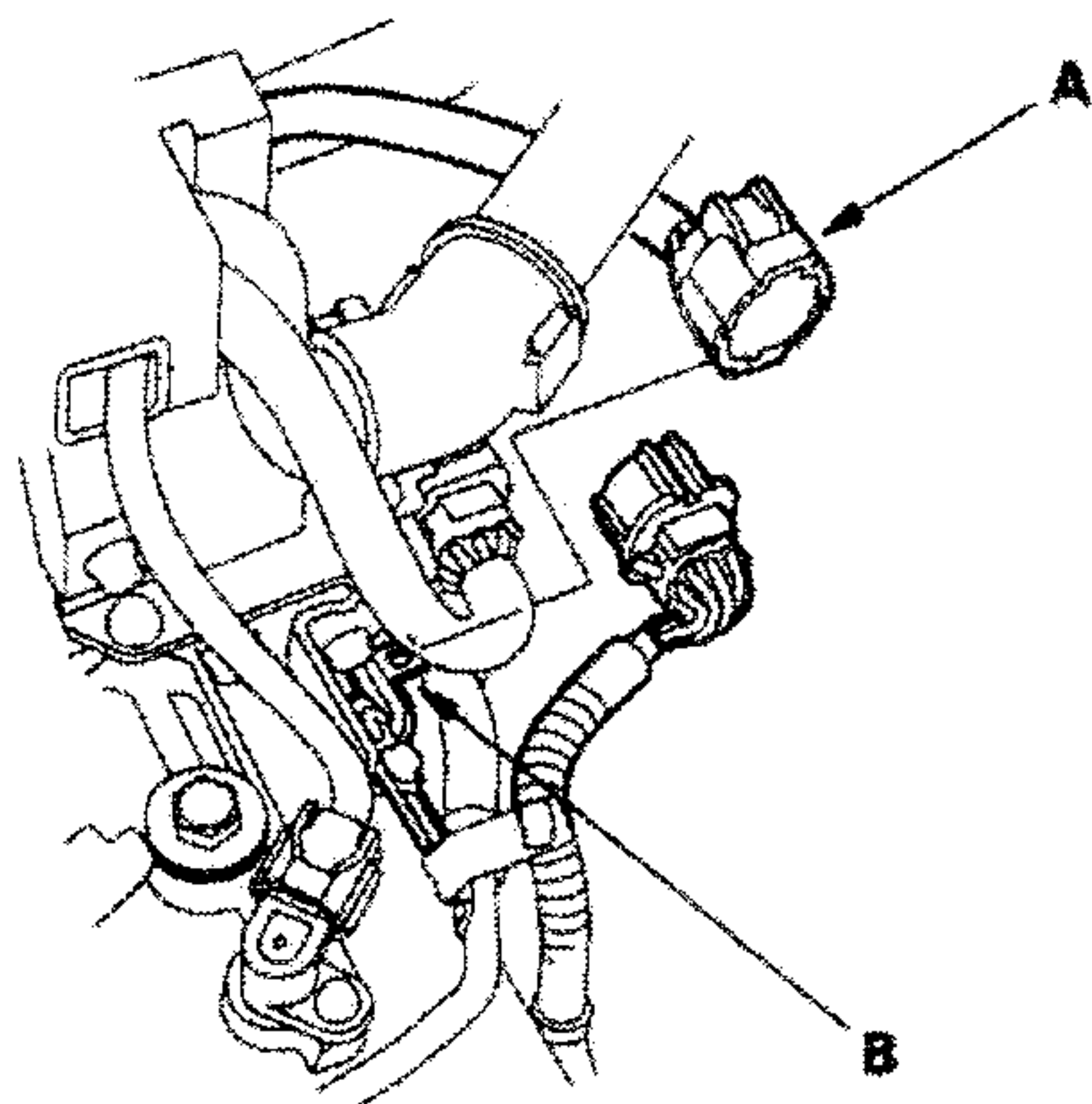

12. Turn the ignition switch ON (II). Move the shift lever through all gears, and check the transmission range switch synchronization with the A/T gear position indicator.

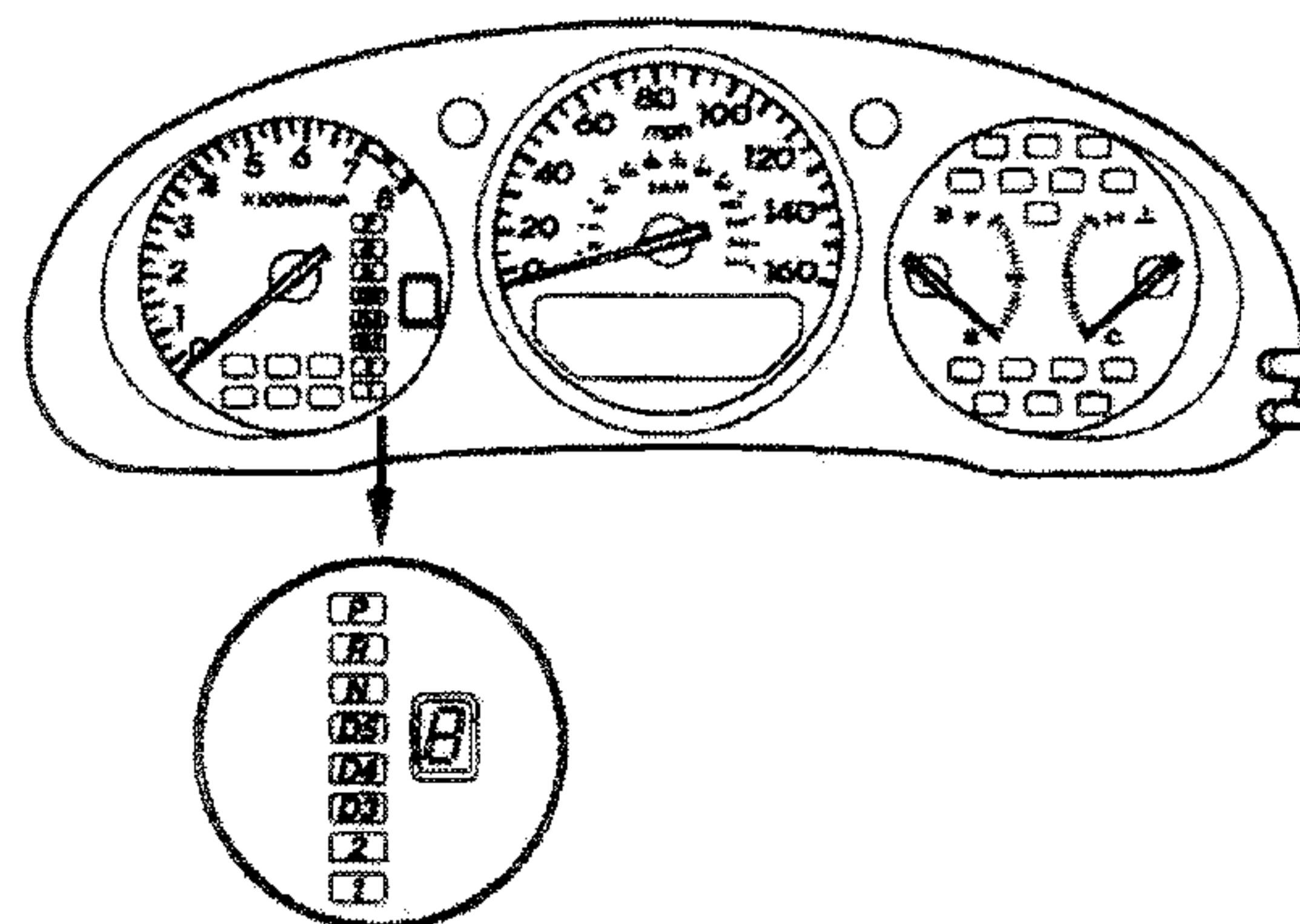

13. Start the engine. Move the shift lever through all gears, and verify the following:

- The engine will not start in any position other than **N** or **P**.
- The back-up lights come on when the shift lever is in the **R** position.