

2. Remove the front bumper:

- Remove the eight clips, two bolts, and two self-tapping screws.
- Unplug the fog light connectors.
- Remove the bumper and rest it on a blanket to prevent it from being scratched, while you install the under spoiler.

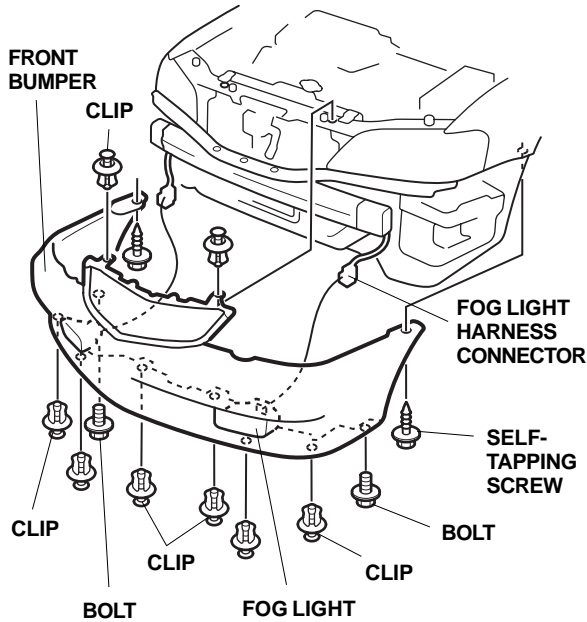

3. Remove the three clips, and release the three hooks that secure the front grille; then remove the front grille.

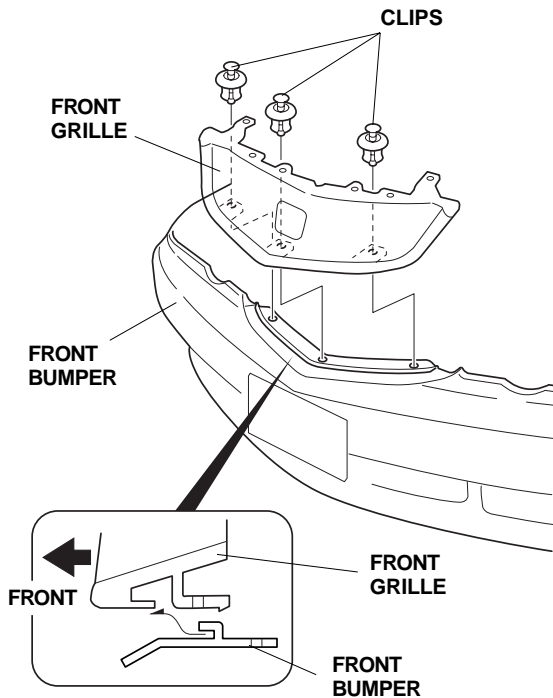

4. Locate the nine dimple marks on the bottom of the front bumper. If necessary, place the under spoiler on the bumper to locate the marks.

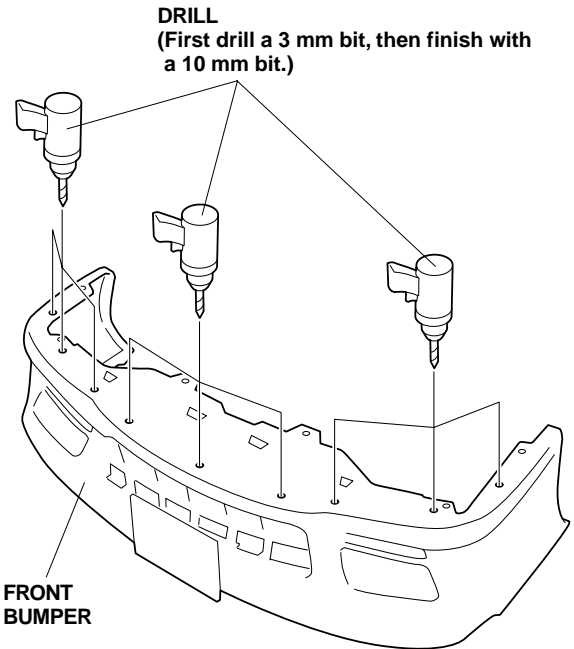

5. Center-punch each mark, and, drill a 3 mm hole, then a 10 mm hole through each mark. Remove all burrs from the edges of the holes.
6. At each end of the bumper, slide two spring nuts over the dimpled areas of the bumper.

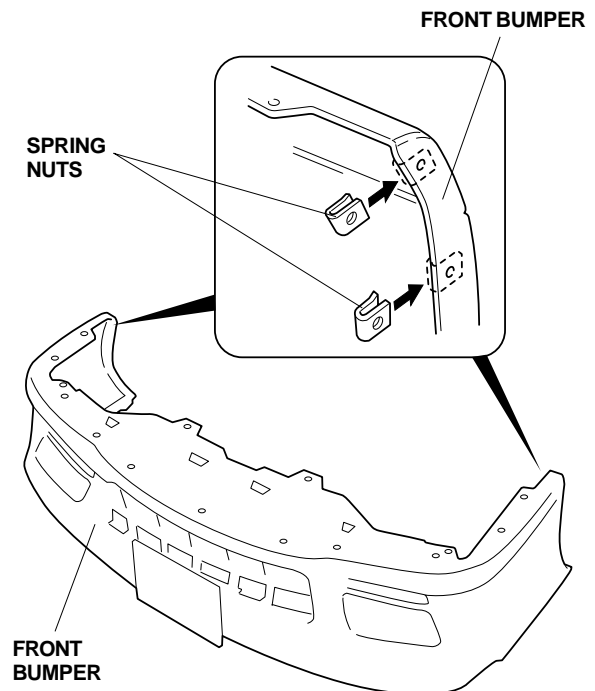

- On the inside of the front under spoiler, locate the two adhesive tapes. Attach a small strip of masking tape to the end of each adhesive tape backing to help peel back the adhesive backing. Remove about 2 inches of the adhesive backing, fold it downward, and attach it to the front of the under spoiler with a strip of masking tape.

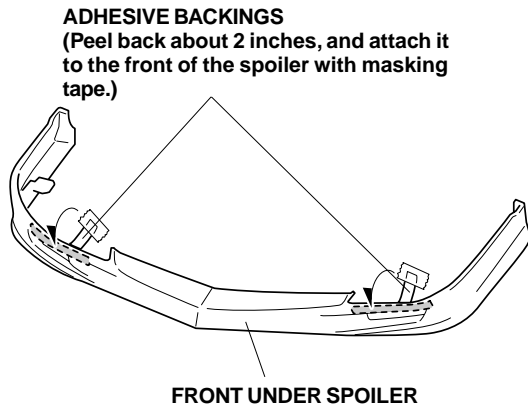

- Using isopropyl alcohol on a shop towel, thoroughly clean the front bumper where the front under spoiler will be attached.

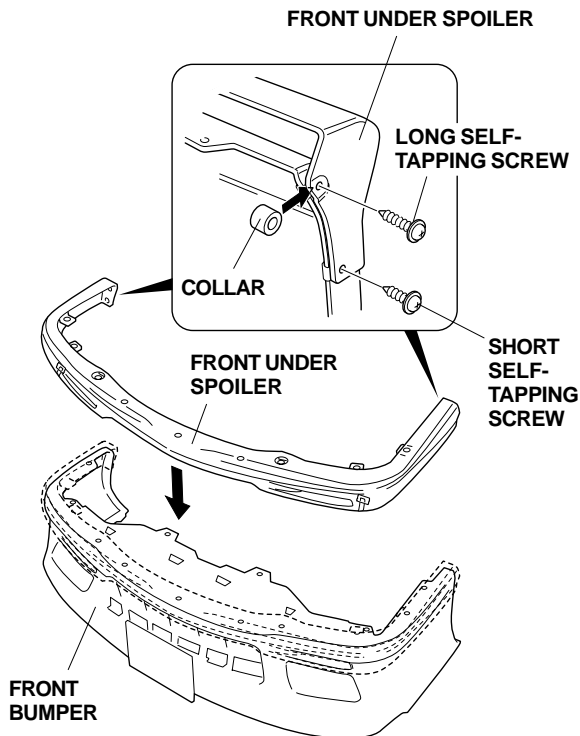

- Position the front under spoiler on the front bumper, and install the two long and two short self-tapping screws with one collar on each side placed between the front under spoiler and the front bumper.

- Secure the front under spoiler to the front bumper with the three bumper bolts, six flange bolts, and nine flange nuts in the kit. Be careful not to mix up the bumper bolts with the flange bolts.

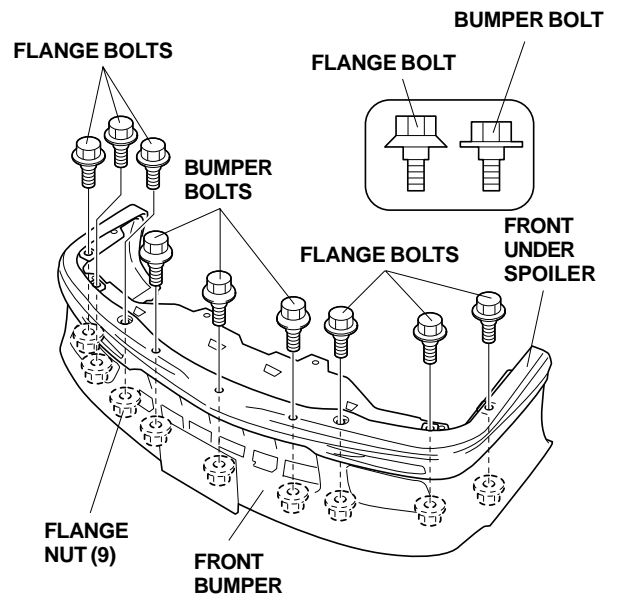

- While holding light pressure against the front under spoiler, slowly and carefully remove the adhesive backings. In several places, press the front under spoiler firmly against the front bumper with the palm of your hand for 30 seconds.

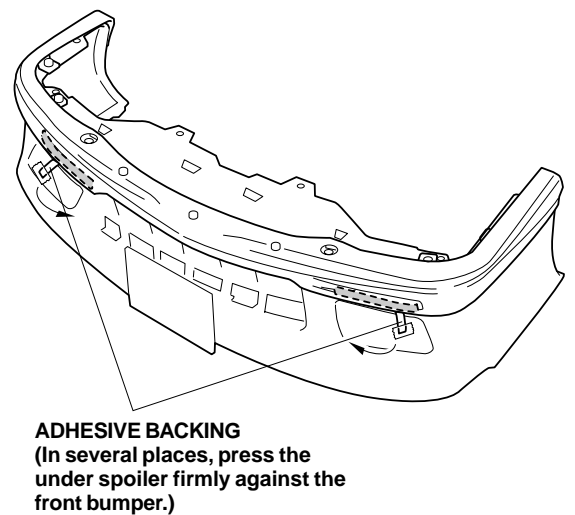

- Reinstall the front grille, the front bumper and the front bulkhead cover. Make sure that all clips are installed securely.