

REMOVAL & INSTALLATION > FRONT BRAKE DISC REMOVAL AND INSTALLATION > REMOVAL**NOTE:** Keep grease away from the brake disc and the brake pads.

1. Vehicle - Lift

1. Raise and support the vehicle .

2. Front Wheel - Remove

1. Remove the front wheel .

3. Brake Caliper - Remove

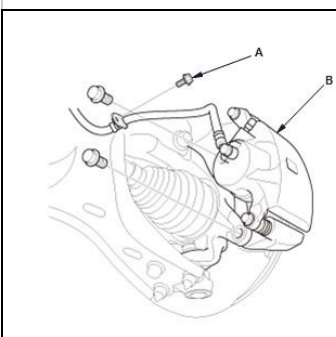

Courtesy of HONDA, U.S.A., INC.

1. Remove the brake hose mounting bolt (A).
2. Remove the brake caliper assembly (B).

NOTE:

1. To prevent damage to the caliper assembly or brake hose, use a short piece of wire to hang the caliper assembly from the undercarriage.
2. Do not twist the brake hose excessively.

4. Brake Disc - Remove

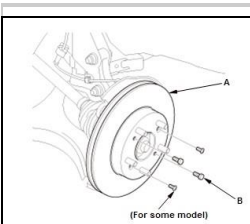
Courtesy of HONDA,
U.S.A., INC.

1. Remove the brake disc (A).

NOTE: If the brake disc is stuck to the front hub, thread two 8 x 1.25 mm bolts (B) into the brake disc to push it away from the front hub. Turn each bolt 90 degrees at a time to prevent the brake disc from binding.

REMOVAL & INSTALLATION > FRONT BRAKE DISC REMOVAL AND INSTALLATION > INSTALLATION**NOTE:** Keep grease away from the brake disc and the brake pads.

1. Brake Disc - Install

Fig 1: Brake Disk Retaining Bolts Torque Specifications

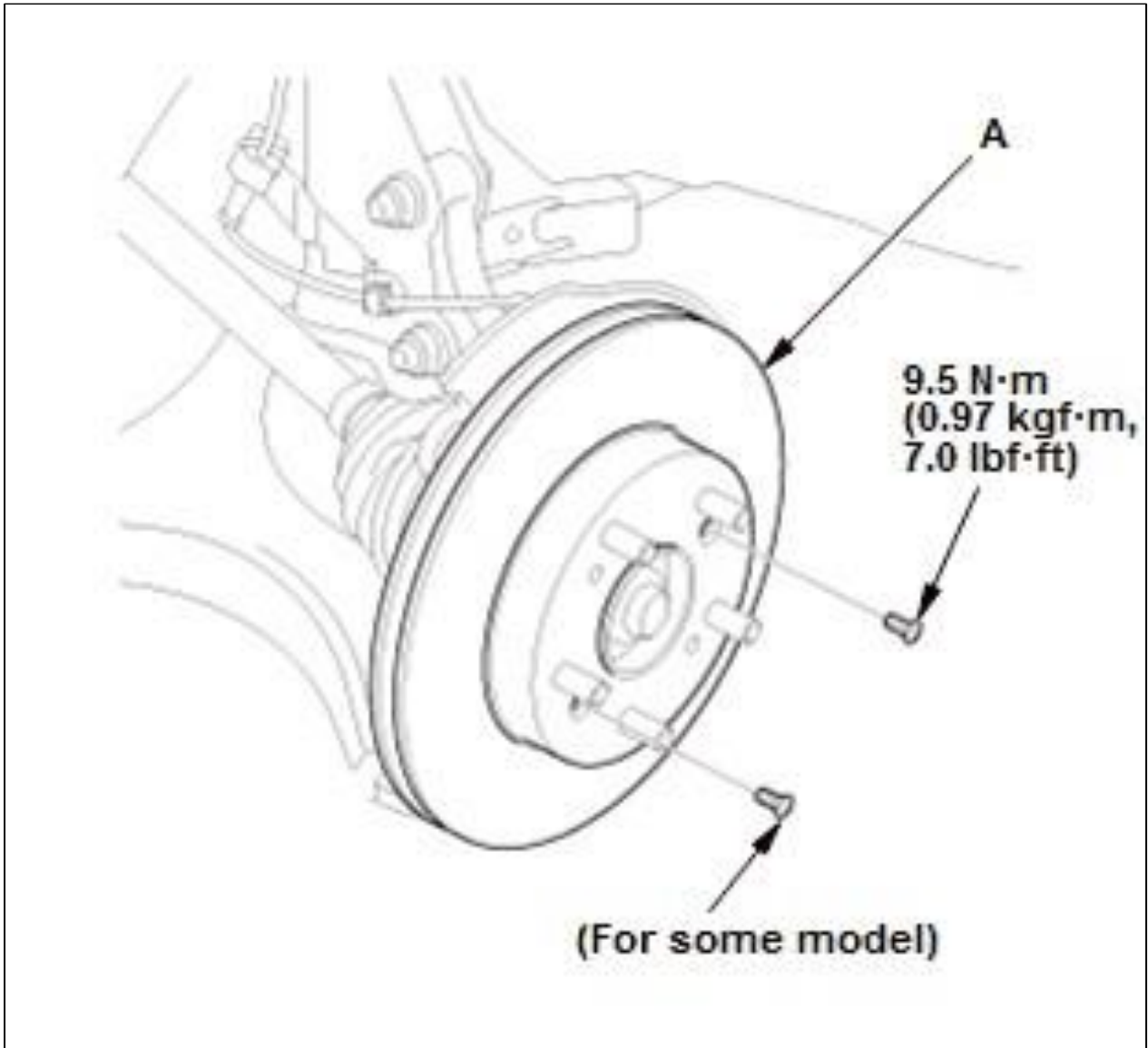

Courtesy of HONDA, U.S.A., INC.

1. Install the brake disc (A).

NOTE: Before installing the brake disc, clean the mating surfaces between the front hub and the inside of the brake disc.

2. Brake Disc Runout - Inspect

1. Inspect the brake disc runout - Refer to: Front Brake Disc Inspection (2013-15), or Front Brake Disc Inspection (2016-19) .

3. Brake Caliper - Install

Fig 2: Brake Caliper Bolts And Brake Hose Mounting Bolt Torque Specifications

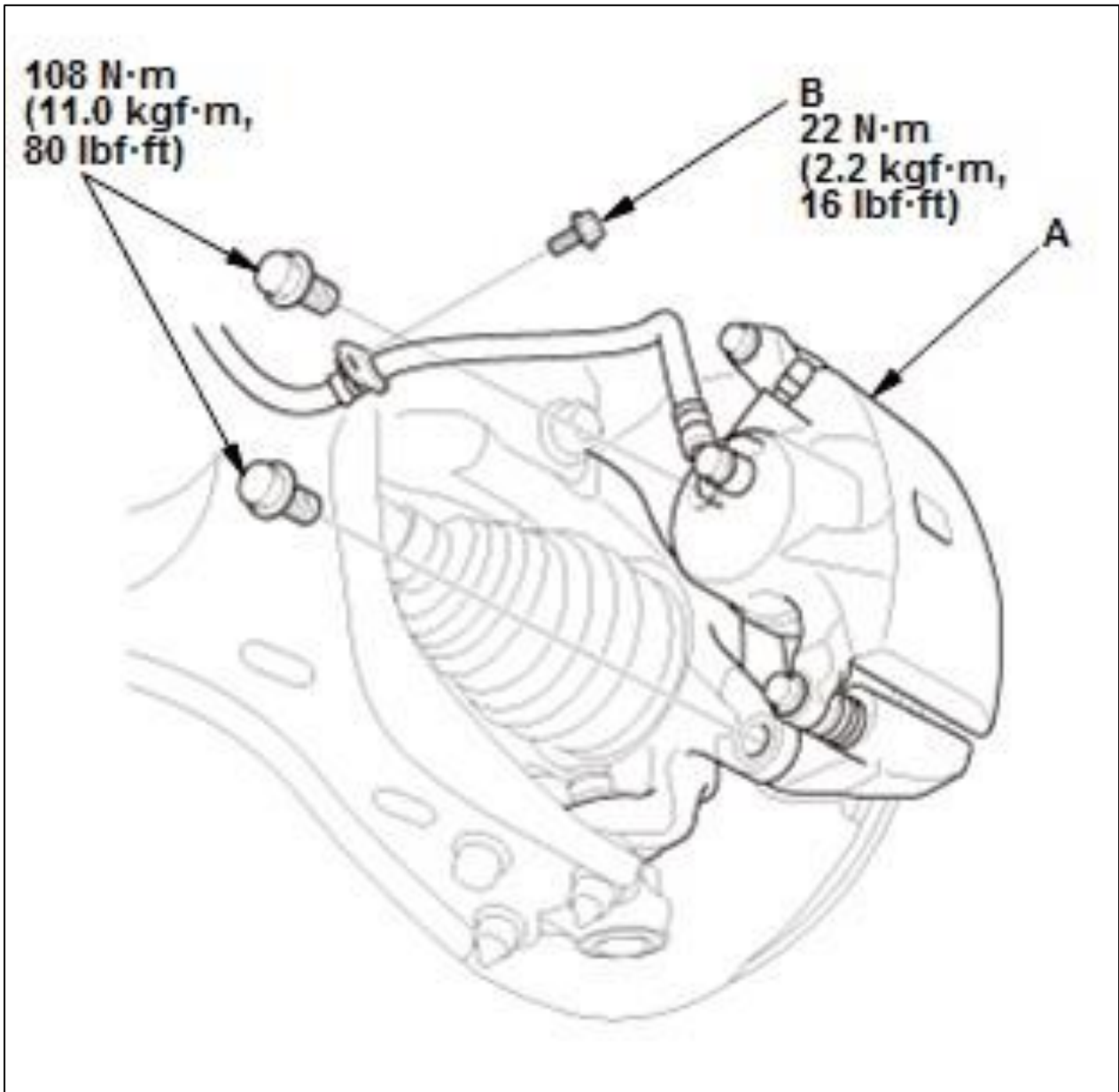

Courtesy of HONDA, U.S.A., INC.

1. Install the brake caliper assembly (A).
2. Install the brake hose mounting bolt (B).

4. Front Wheel - Install

1. Install the front wheel .