

DESCRIPTION > POWER TAILGATE SYSTEM DESCRIPTION - COMPONENTS (2013-15)

Driver's Power Tailgate Switch

The power tailgate can be open/closed automatically by using the driver's power tailgate switch.

Remote

The power tailgate can be open/closed automatically by pressing the power tailgate button of the remote.

Tailgate Outer Handle Switch

The tailgate outer handle switch can be used to manually open the power tailgate.

Power Tailgate Inside Switch

The power tailgate inside switch is equipped on the lower tip of the tailgate, and it can be used to automatically close the power tailgate.

Power Tailgate Sensor

The power tailgate sensor detects the opening/closing angle and the opening/closing speed of the power tailgate.

Power Tailgate Inside Beeper

The tailgate inside beeper generates a sound during the operation of the power tailgate.

Power Tailgate Drive Unit

The power tailgate drive unit consists of the motor, magnet clutch, gear, and power tailgate sensor, and receives signals from the power tailgate control unit to open or close the tailgate. When the power tailgate drive unit receives signals from the power tailgate control unit, it activates the magnet clutch, motor, and gear to rotate the arm.

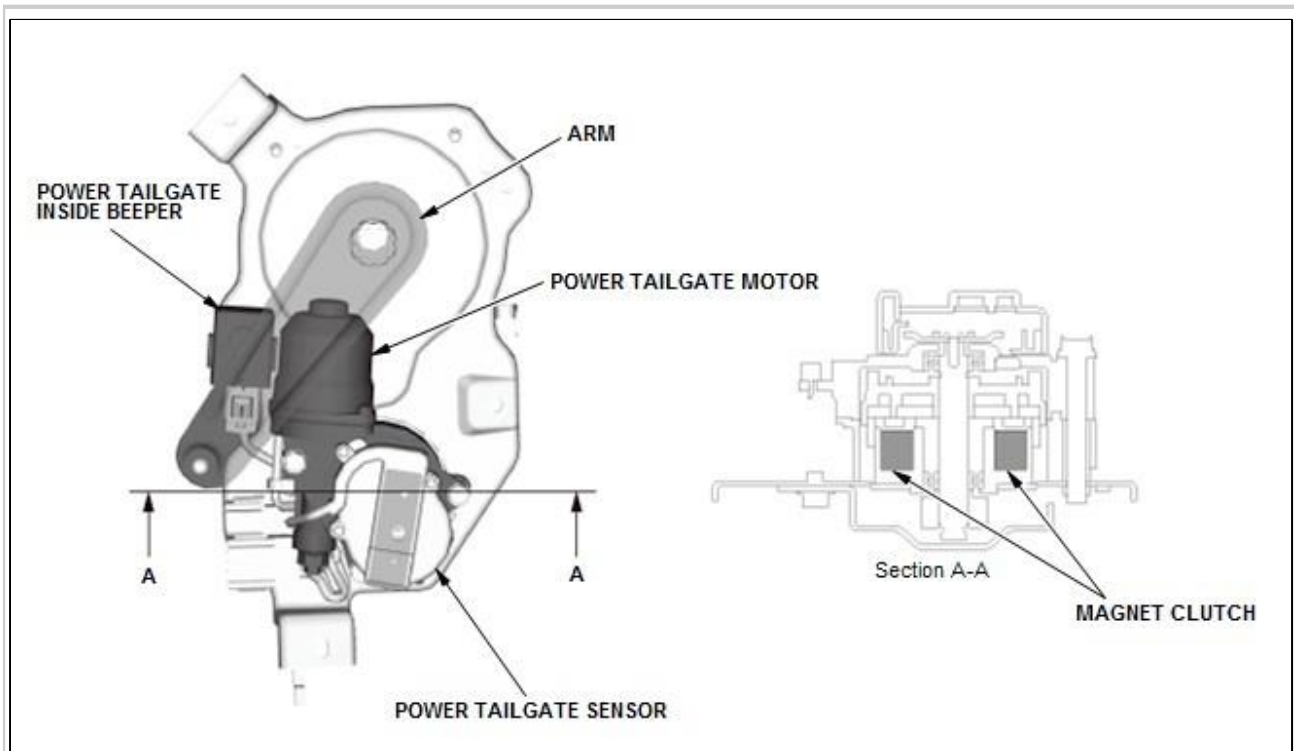

Courtesy of HONDA, U.S.A., INC.

Power Tailgate Closer Unit

The power tailgate closer unit consists of the closer motor, the sector gear, the latch, and so forth.

Several switches are used to detect the position of the component parts.

Upon a tailgate close request, the latch switch detects that the tailgate is in the half-shut position. Then, the closer motor begins to rotate in the closing direction until the tailgate reaches the full-close position.

Upon a tailgate open request, the closer motor begins to rotate in the opening direction until the sector gear unlocks the latch.

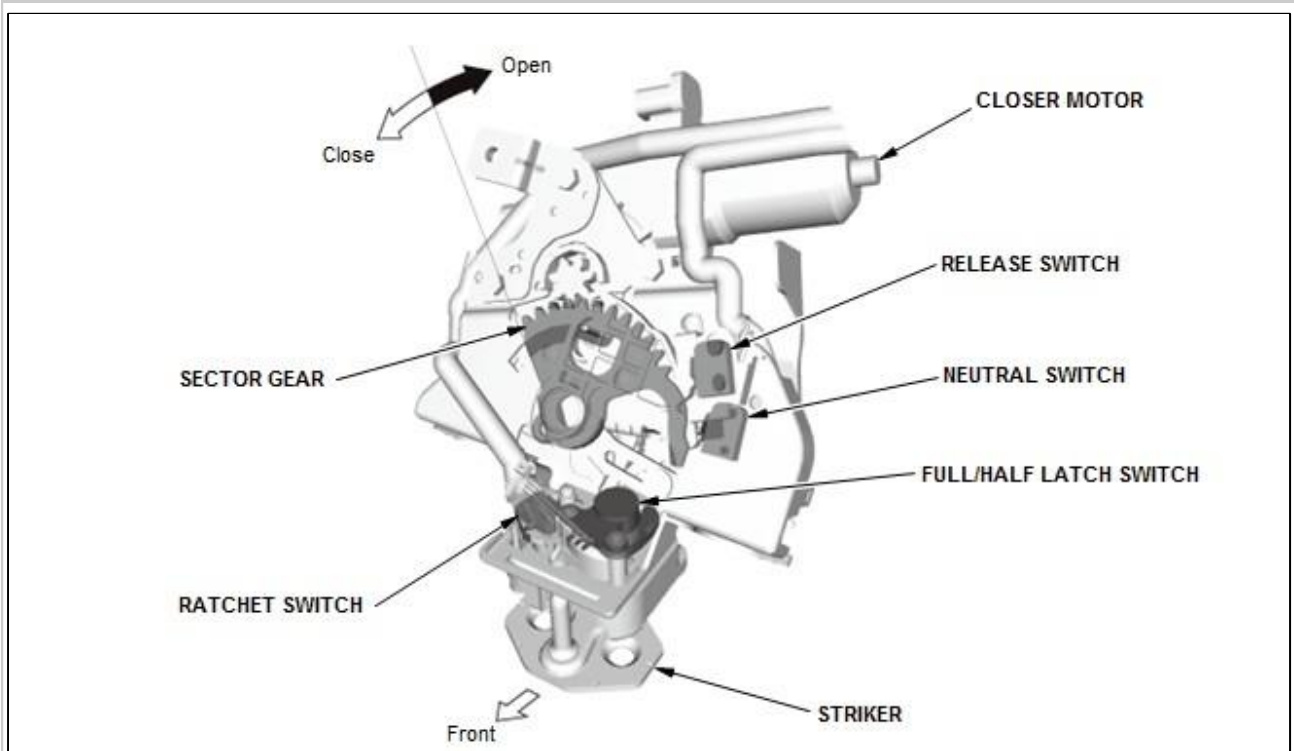

Courtesy of HONDA, U.S.A., INC.

Pinch Sensor

The pinch sensor is attached at either end of the tailgate and is equipped to prevent the pinching during auto close. When the pinch sensor is compressed, the embedded conductive rubbers contact each other and the resistance value of the sensor varies. This signal is transmitted to the power tailgate control unit and the unit reverse the operation from the auto close to the auto open based on the information.

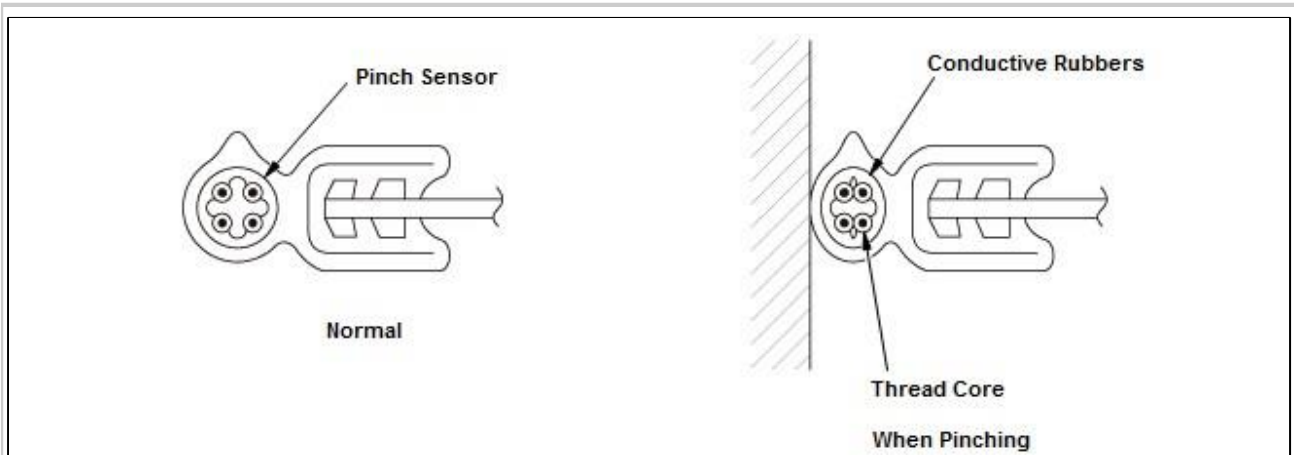

Courtesy of HONDA, U.S.A., INC.

DESCRIPTION > POWER TAILGATE SYSTEM DESCRIPTION - COMPONENTS (2016-17)

Driver's Power Tailgate Switch

The power tailgate can be open/closed automatically by using the driver's power tailgate switch.

Remote

The power tailgate can be open/closed automatically by pressing the power tailgate button of the remote.

Tailgate Outer Handle Switch

The power tailgate can be automatically opened by operating the tailgate outer handle switch within one second. The tailgate can be manually opened by operating the tailgate outer handle switch more than one second.

Power Tailgate Inside Switch

The power tailgate inside switch is equipped on the lower tip of the tailgate, and it can be used to automatically close the power tailgate.

Power Tailgate Sensor

The power tailgate sensor detects the opening/closing angle and the opening/closing speed of the power tailgate.

Power Tailgate Inside Beeper

The tailgate inside beeper generates a sound during the operation of the power tailgate.

Power Tailgate Drive Unit

The power tailgate drive unit consists of the motor, magnet clutch, gear, and power tailgate sensor, and receives signals from the power tailgate control unit to open or close the tailgate. When the power tailgate drive unit receives signals from the power tailgate control unit, it activates the magnet clutch, motor, and gear to rotate the arm.

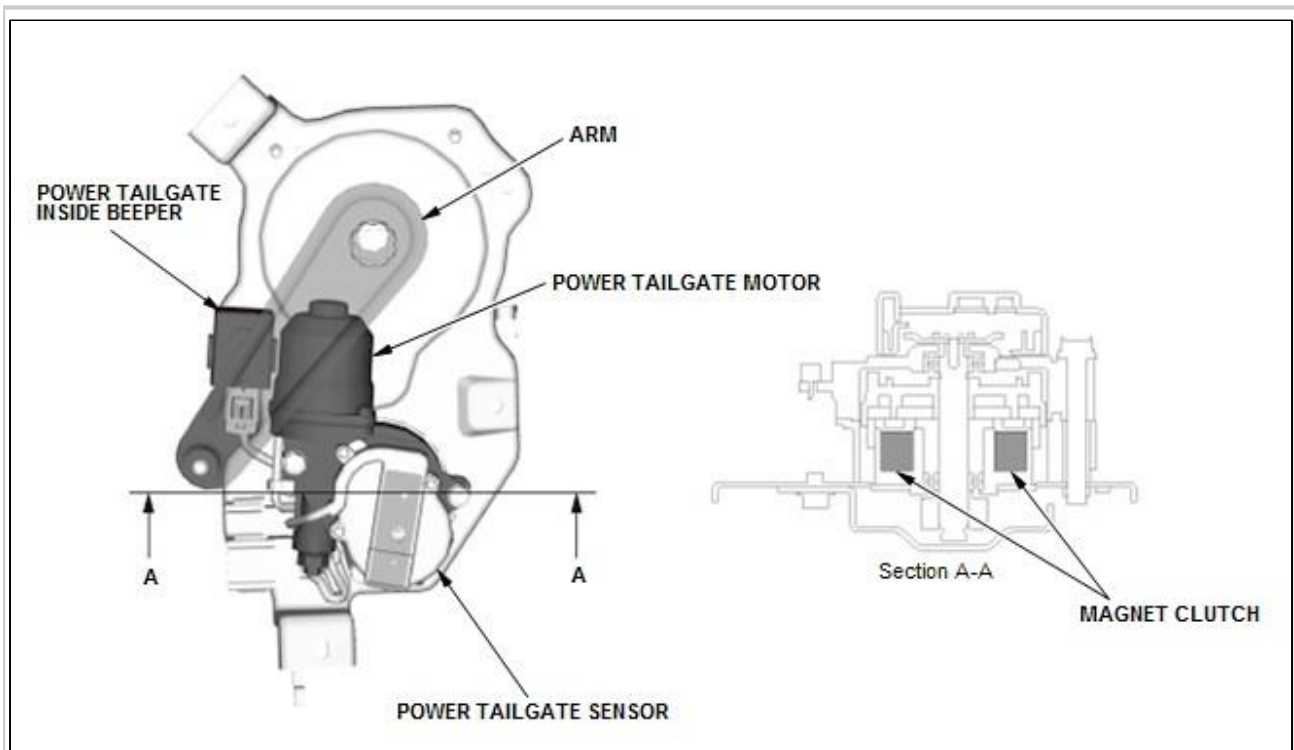

Courtesy of HONDA, U.S.A., INC.

Power Tailgate Closer Unit

The power tailgate closer unit consists of the closer motor, the sector gear, the latch, and so forth. Several switches are used to detect the position of the component parts.

Upon a tailgate close request, the latch switch detects that the tailgate is in the half-shut position. Then, the closer motor begins to rotate in the closing direction until the tailgate reaches the full-close position. Upon a tailgate open request, the closer motor begins to rotate in the opening direction until the sector gear unlocks the latch.

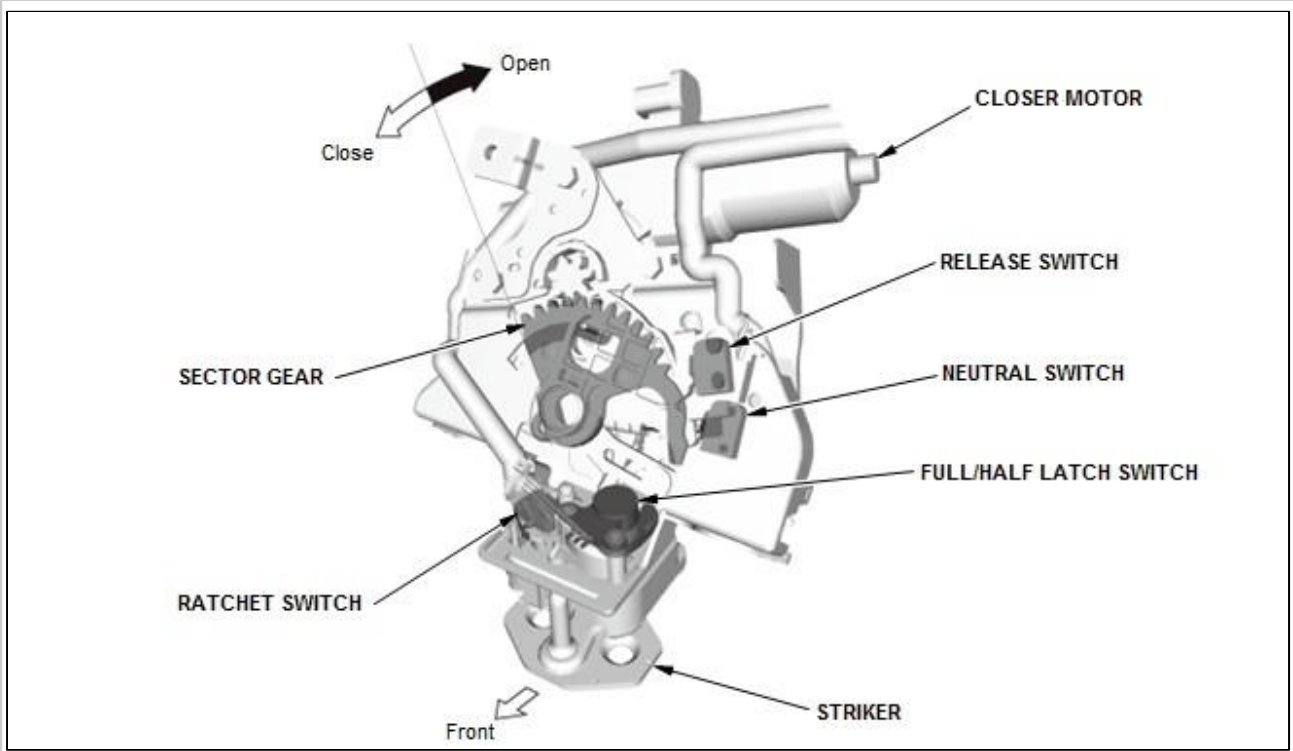

Courtesy of HONDA, U.S.A., INC.

Pinch Sensor

The pinch sensor is attached at either end of the tailgate and is equipped to prevent the pinching during auto close. When the pinch sensor is compressed, the embedded conductive rubbers contact each other and the resistance value of the sensor varies. This signal is transmitted to the power tailgate control unit, and the control unit reverses the operation from the auto close to the auto open based on the information.

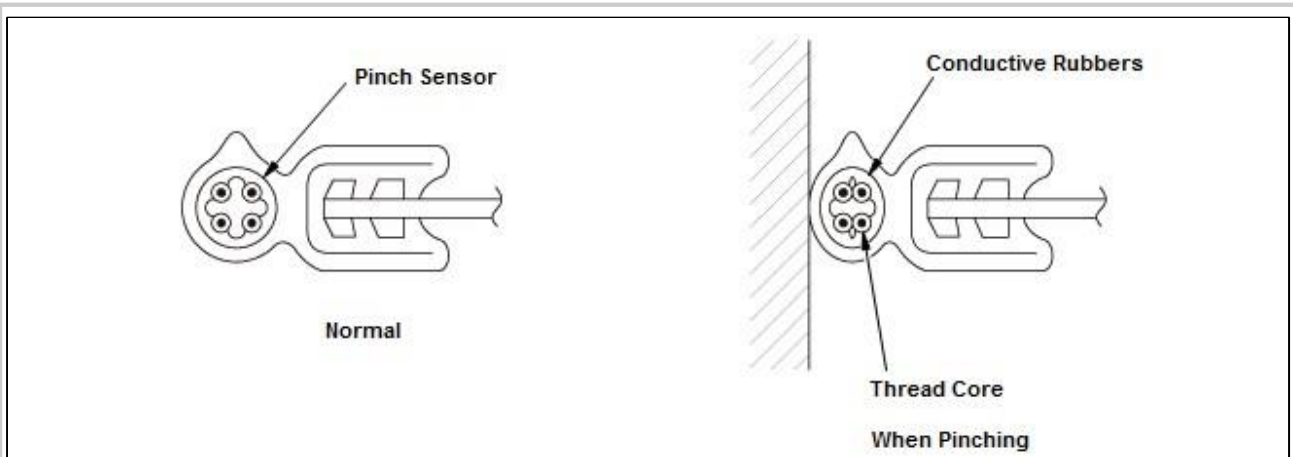

DESCRIPTION > POWER TAILGATE SYSTEM DESCRIPTION - CONTROL/FUNCTION (2013-15)

Basic Operation

The power tailgate can be opened and closed automatically by operating the driver's power tailgate switch, the tailgate inside switch (for close), the tailgate outer handle switch, and the remote.

Auto Open Operational Conditions

The power tailgate can be opened by operating the driver's power tailgate switch, the tailgate outer handle switch, and the remote under the following conditions:

Operational Conditions (In the turn the vehicle to the ON mode (the keyless operations are disabled in the vehicle to the ON mode))

- Tailgate is fully closed.
- The vehicle speed is less than 1.2 mph (2 km/h).
- The transmission range is P.
- Door lock knob switches of all doors are unlocked.
- Power tailgate closer unit detects the neutral position.
- System is not in failsafe mode.
- The power supply voltage is 11 V or higher.

Operational Conditions (in the turn the vehicle to the OFF (LOCK) mode)

- Tailgate is fully closed (full-latched position is detected).
- Vehicle OFF (LOCK) mode (keyless operation only).
- The vehicle speed is less than 1.2 mph (2 km/h).
- Door lock knob switches of all doors are unlocked.
- Closer unit detects the neutral position.
- System is not in fail-safe mode.
- The power supply voltage is 11 V or higher.

Auto Close Operational Conditions

The power tailgate can be closed by operating the driver's power tailgate switch, tailgate inside switch, and the remote under the following conditions:

- Tailgate is fully open.
- Power tailgate closer unit detects the neutral position.
- Pinch sensor detects no obstruction.
- System is not in failsafe mode.
- The power supply voltage is 11 V or higher.
- Half latch switch is ON.

Operation Stop Conditions

Operation stop occurs in the following conditions:

- During the open operation, and the detected vehicle speed is 1.2 mph (2 km/h) or more.
- During the open or close operation, and the tailgate outer handle switch is ON.
- During the open or close operation, and failsafe is detected. (Except for the power tailgate closer unit failure.)

- During the open or close operation, and the current at the power tailgate motor is 30 A or more for at least 0.5 seconds.

Pinching Detection Control

When something is pinched (hit) during the open/close operation of the power tailgate, pinching is detected and the motor of the power tailgate drive unit is stopped to reverse the rotation. There are two types of detection methods, the direct detection method and the indirect detection method.

1. Direct Detection Method (Pinch Sensor Detection)

In this method, the change in the internal resistance due to oppression of the pinch sensor during the auto close operation is detected to determine the existence of pinching.

2. Indirect Detection Method

- Pulse detection (Overload detection)
In this method, the change in the pulse width output from the pulse sensor during the auto open/close operation is detected to determine the existence of pinching.
- Current detection
In this method, the change in the load calculated value from the power tailgate motor current during the auto open/close operation is detected to determine the existence of pinching.

Power Tailgate Open/Close Speed Control

The power tailgate open/close speeds are detected from the pulse signals of the pulse sensor and, based on the open/close position of the tailgate, the speed control is carried out to follow the preset target speed.

Fall-down Detection Function

This function prevents the tailgate from suddenly falling down because of an accumulation of snow, or other causes. If the power tailgate drive unit detects abnormal pulses, the tailgate starts to open. If this operation is activated twice, the tailgate will close automatically. If the obstruction detection function detects any obstruction several times during this fall-down detection function, the tailgate stops moving.

Power Tailgate Answer Back Control

Power tailgate causes the front side marker lights/parking lights to blink 3 times by the answer back feature, which is activated by operating the power tailgate button on the remote, or by operating the driver's power tailgate switch.

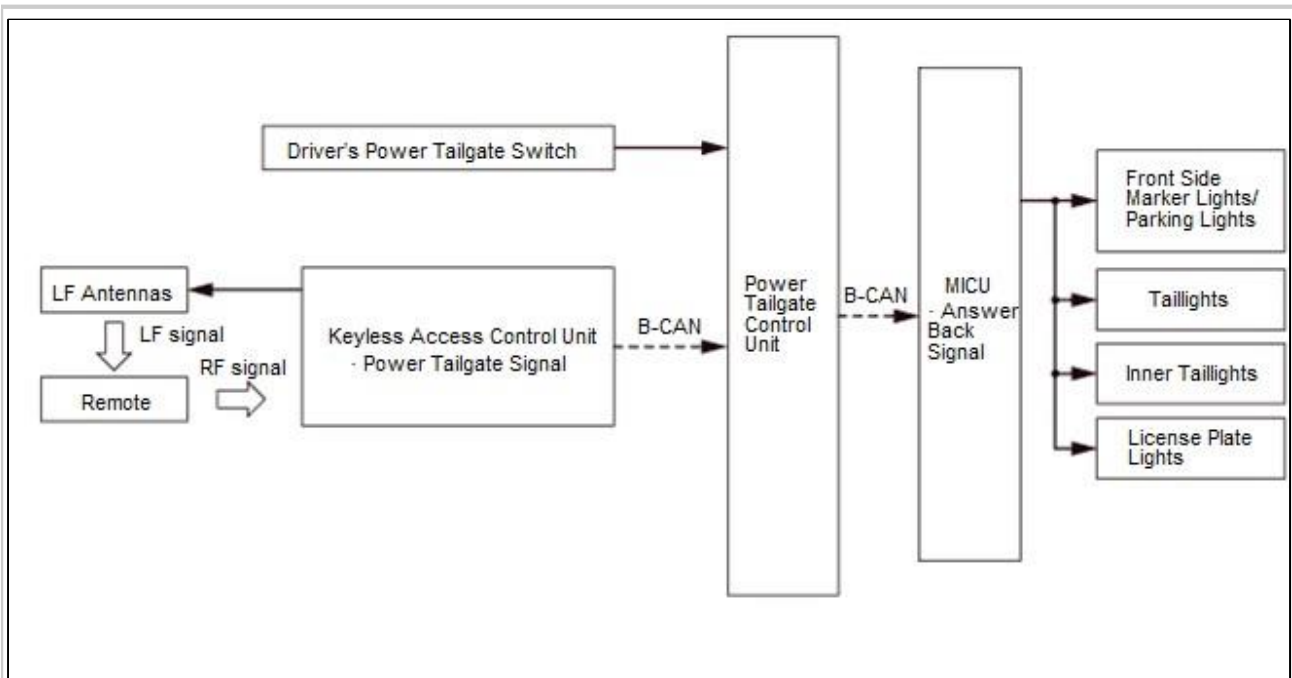

Beeper Sound Function

The beeper sound function activates the beeper sound when the operation is stopped, pinching is detected, the close operation is performed while the vehicle speed is detected, the auto operation is carried out while the door fall prevention function, etc. There are some beeper sound patterns as shown below.

Warning Sound (1)

- When the tailgate starts to open automatically (excluding when operating the tailgate outer handle switch)
- When the tailgate starts to close automatically

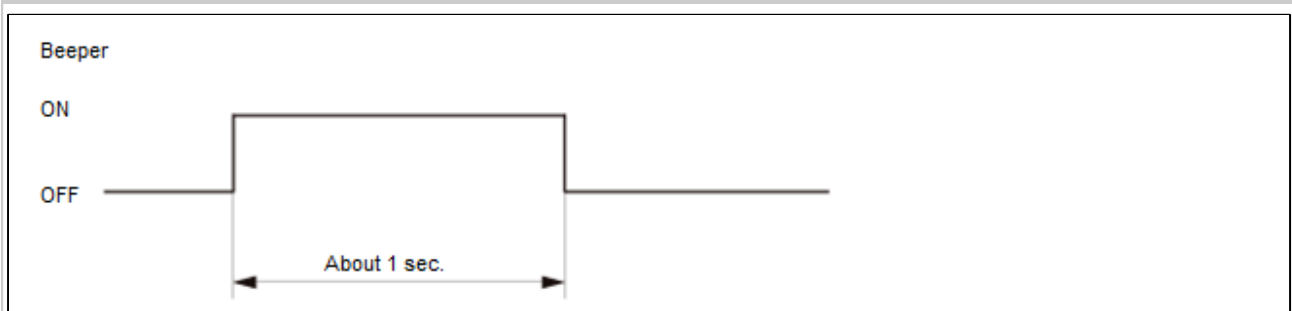

Courtesy of HONDA, U.S.A., INC.

Warning Sound (2)

- When the reverse operation is started after the tailgate has detected any obstruction.
- When the reverse operation is started by each switch operation.
- When the following stopping conditions are met when auto is operating:
 - During the open operation, and the vehicle speed is 1.2 mph (2 km/h) or more is detected.
 - When failsafe is detected. (Except for the power tailgate closer unit failure.)
- When the operating time is over.
- When the following release conditions are met when the power tailgate closer unit is operating:
 - The pinch sensor ON is detected.
 - Failsafe of the pinch sensor is detected.

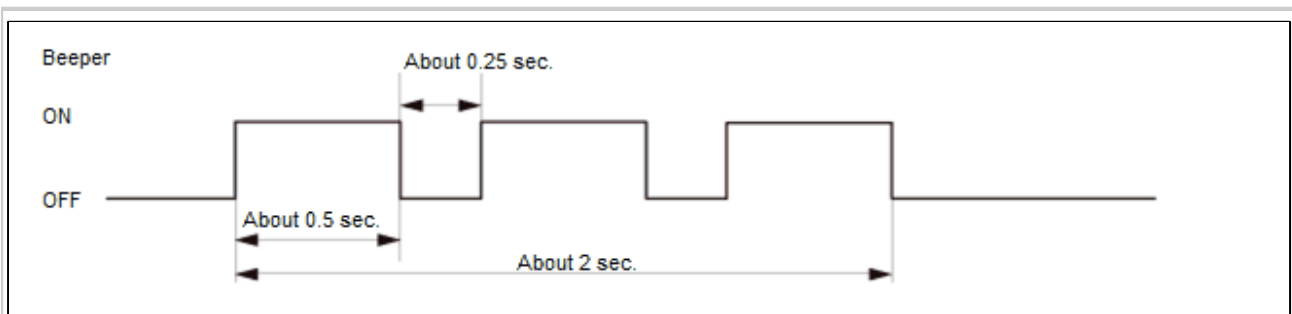

Courtesy of HONDA, U.S.A., INC.

Warning Sound (3)

- When the vehicle speed exceeds 1.2 mph (2 km/h) while the tailgate is closing automatically

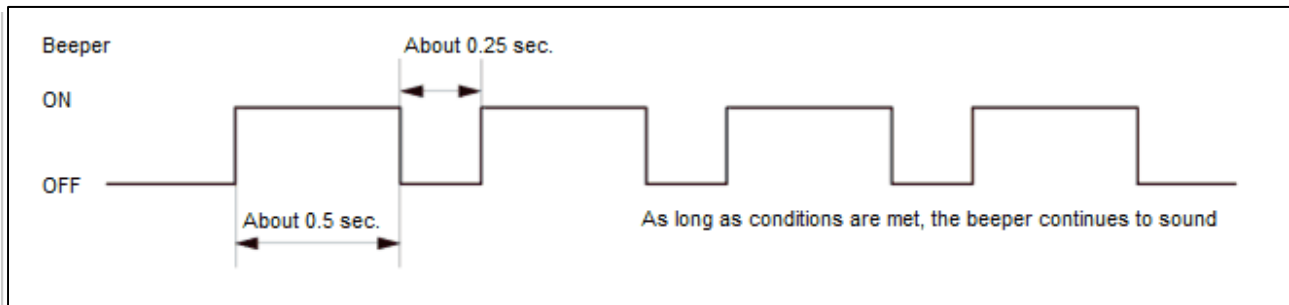

Courtesy of HONDA, U.S.A., INC.

The beeper sound is stopped when the following conditions are met.

- When the full latch switch OFF and the latchet switch ON is detected.
- Vehicle speed of 1.2 mph (2 km/h) or less is detected.
- Close operation is stopped.

Warning Sound (4)

When the tailgate fall-down detection function is activated. (Closing operation when the tailgate fall-down detection function is activated or after second inspection.)

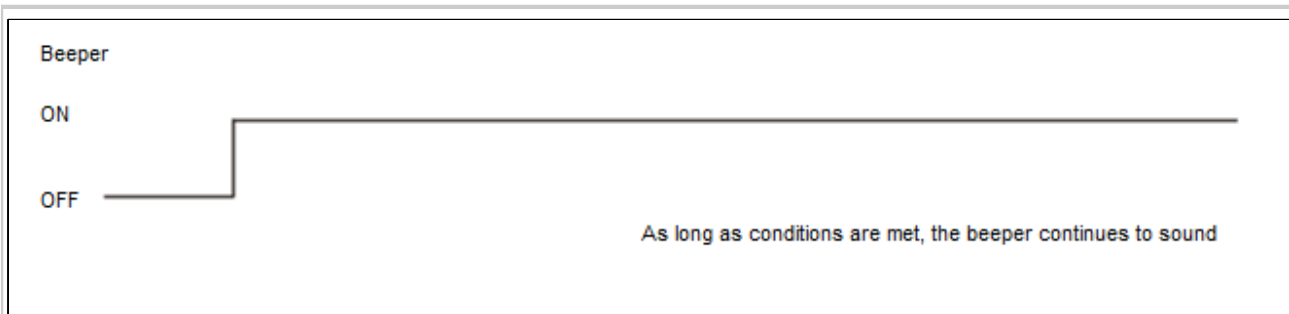

Courtesy of HONDA, U.S.A., INC.

The beeper sound is stopped when the following conditions are met.

- When the full latch switch OFF or the half latch switch OFF is detected.
- Fall-down detection operation is stopped.

Warning Sound (5)

When the tailgate is not fully-latched, and the following condition is met: The shift lever is in any position other than P, the brake pedal position switch, and the parking brake switch is OFF, and the vehicle speed exceeds 1.2 mph (2 km/h).



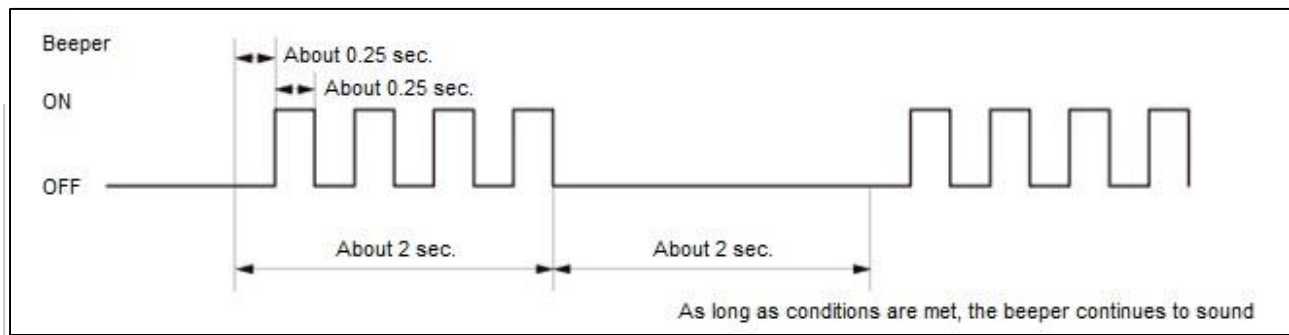

Courtesy of HONDA, U.S.A., INC.

The beeper sound is stopped when the following conditions are met.

- 31 cycles beeper sound is completed.
- Vehicle OFF (LOCK) mode.
- When the full latch switch OFF and the latchet switch ON is detected.
- Vehicle speed is 1.2 mph (2 km/h) or below and the ATP or the foot brake and the parking brake is ON.

Sector Gear Neutral Position Reset Control

The power tailgate closer unit operates normally (within standard) with the neutral switch OFF, so when starting an operation, it resets the sector gear to neutral position.

DESCRIPTION > POWER TAILGATE SYSTEM DESCRIPTION - CONTROL/FUNCTION (2016-17)

Basic Operation

The power tailgate can be opened and closed automatically by operating the driver's power tailgate switch, the tailgate inside switch (for close), the tailgate outer handle switch, and the remote.

Auto Open Operational Conditions

The power tailgate can be opened by operating the driver's power tailgate switch, the tailgate outer handle switch (operating within one second), and the remote under the following conditions (The keyless operations are disabled with the vehicle in the ON mode):

- Tailgate is fully closed.
- The vehicle speed is less than 1.2 mph (2 km/h).
- The transmission range is P.
- Power tailgate closer unit detects the neutral position.
- System is not in failsafe mode.
- The power supply voltage is 11 V or higher.

Auto Close Operational Conditions

The power tailgate can be closed by operating the driver's power tailgate switch, the tailgate inside switch, and the remote under the following conditions:

- Tailgate is fully open.
- Power tailgate closer unit detects the neutral position.
- Pinch sensor detects no obstruction.
- System is not in failsafe mode.
- The power supply voltage is 11 V or higher.
- Half latch switch is ON.

Operation Stop Conditions

Operation stop occurs in the following conditions:

- During the open operation, the detected vehicle speed is 1.2 mph (2 km/h) or more.
- During the open or close operation, the tailgate outer handle switch is ON.
- During the open or close operation, and failsafe is detected. (Except for the power tailgate closer unit failure.)
- During the open or close operation, the current at the power tailgate motor is 30 A or more for at least 0.5 seconds.

Pinching Detection Control

When something is pinched (hit) during the open/close operation of the power tailgate, pinching is detected and the motor of the power tailgate drive unit is stopped to reverse the rotation. There are two types of detection methods, the direct detection method and the indirect detection method.

1. Direct Detection Method (Pinch Sensor Detection)

In this method, the change in the internal resistance due to oppression of the pinch sensor during the auto close operation is detected to determine the existence of pinching.

2. Indirect Detection Method

- Pulse detection (Overload detection)
In this method, the change in the pulse width output from the pulse sensor during the auto open/close operation is detected to determine the existence of pinching.
- Current detection
In this method, the change in the load calculated value from the power tailgate motor current during the auto open/close operation is detected to determine the existence of pinching.

Power Tailgate Open/Close Speed Control

The power tailgate open/close speeds are detected from the pulse signals of the pulse sensor, and based on the open/close position of the tailgate, the speed control is carried out to follow the preset target speed.

Fall-down Detection Function

This function prevents the tailgate from suddenly falling down because of an accumulation of snow, or other causes. Even if the power tailgate drive unit detects abnormal pulses, the tailgate starts to open. If this operation is activated twice, the tailgate will close automatically. If the obstruction detection function detects any obstruction several times during this fall-down detection function, the tailgate stops moving.

Power Tailgate Answer Back Control

Power tailgate causes the turn signal lights to blink 4 times by the answer back feature, which is activated by operating the power tailgate button on the remote, or by operating the driver's power tailgate switch.

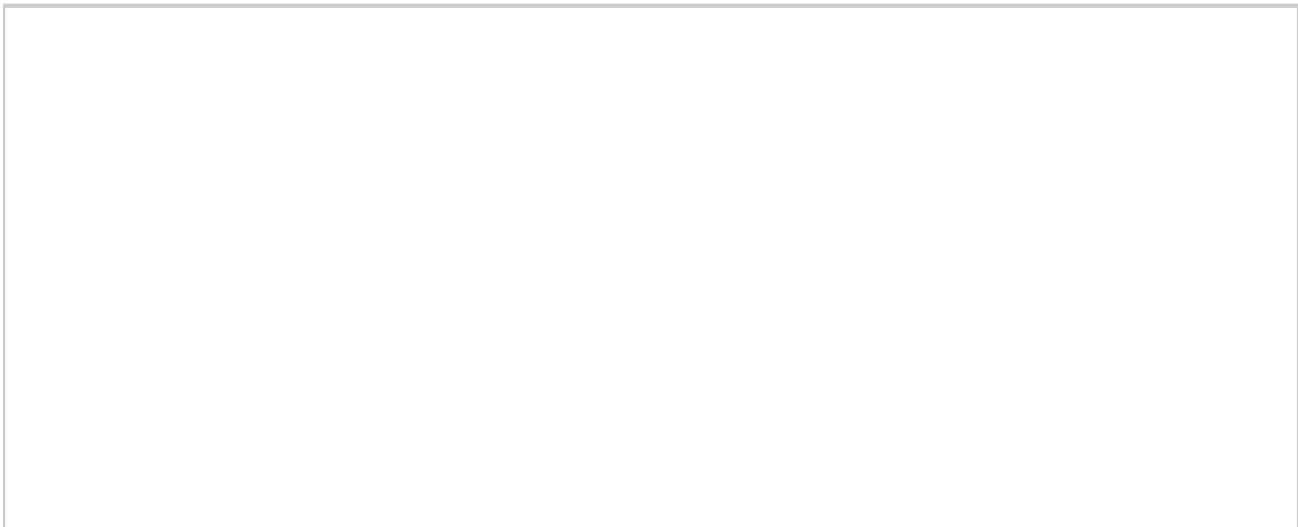

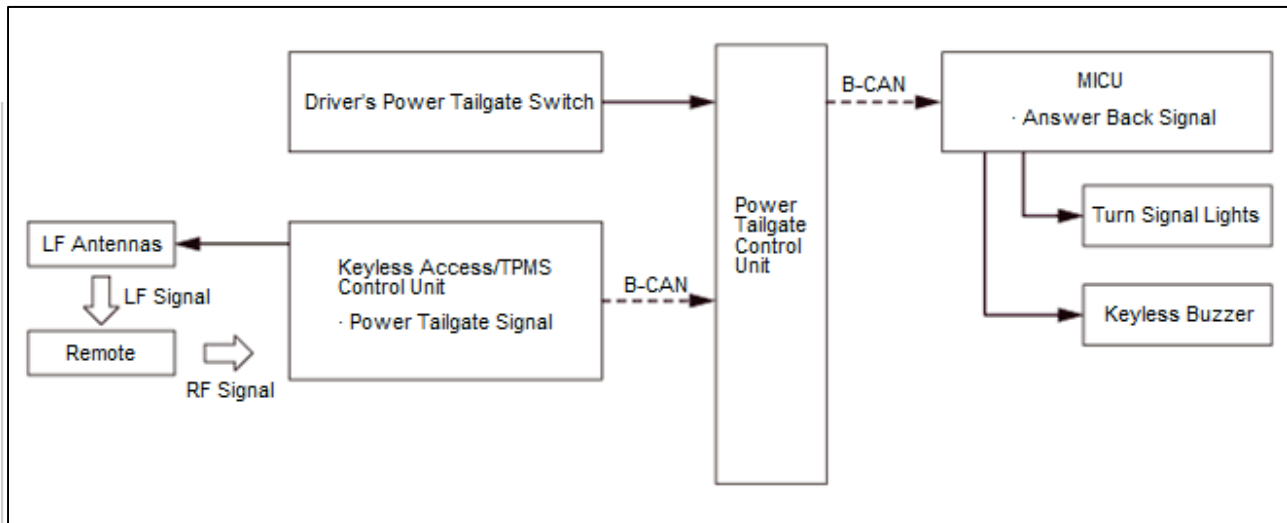

Courtesy of HONDA, U.S.A., INC.

Beeper Sound Function

The beeper sound function activates the beeper sound when the operation is stopped, pinching is detected, the close operation is performed while the vehicle speed is detected, the auto operation is carried out while the door fall prevention function, etc.. There are some beeper sound patterns as shown below.

Warning Sound (1)

- When the tailgate starts to open automatically (excluding when operating the tailgate outer handle switch)
- When the tailgate starts to close automatically

Beeper

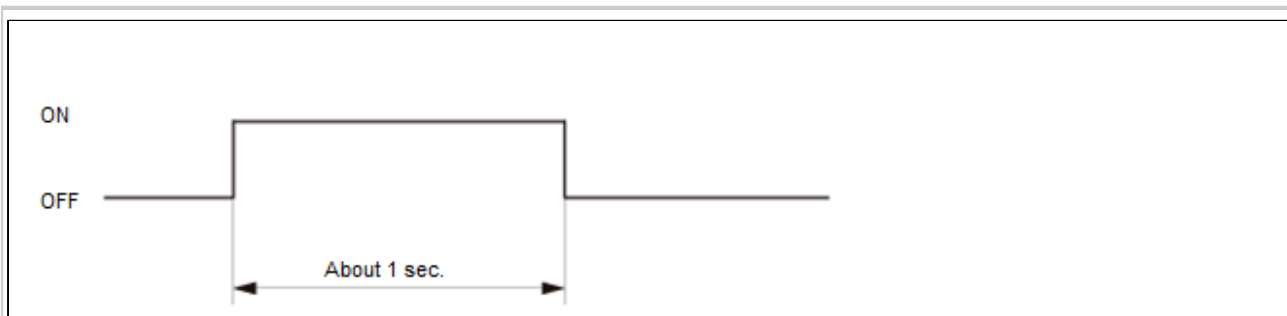

Courtesy of HONDA, U.S.A., INC.

Warning Sound (2)

- When the reverse operation is started after the tailgate has detected any obstruction.
- When the reverse operation is started by each switch operation.
- When the following stopping conditions are met when auto is operating:
 - During the open operation, the vehicle speed of 1.2 mph (2 km/h) or more is detected.
 - When failsafe is detected. (Except for the power tailgate closer unit failure.)
- When the operating time is over.
- When the following release conditions are met while the power tailgate closer unit is operating:
 - The pinch sensor ON is detected.

- Failsafe of the pinch sensor is detected.

Beeper

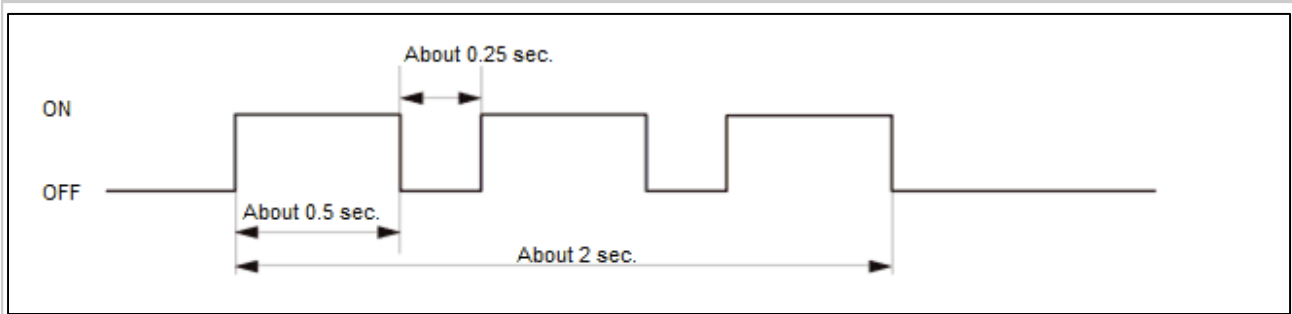

Courtesy of HONDA, U.S.A., INC.

Warning Sound (3)

- When the vehicle speed exceeds 1.2 mph (2 km/h) while the tailgate is closing automatically

Beeper

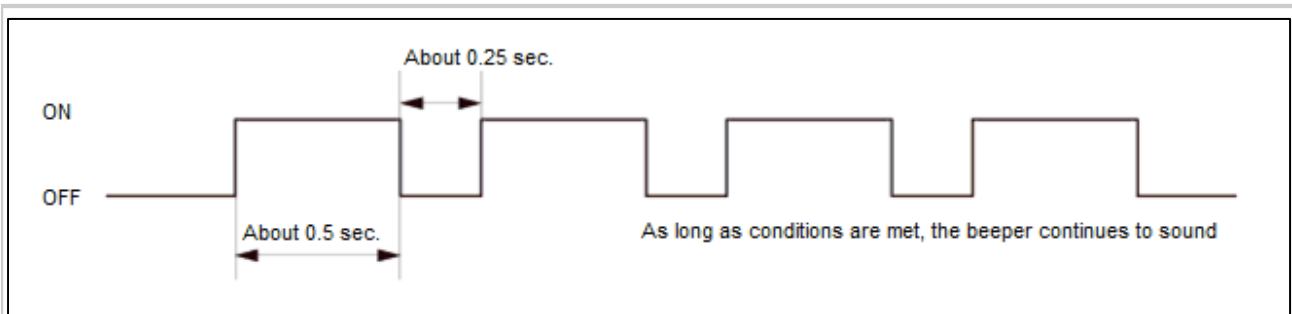

Courtesy of HONDA, U.S.A., INC.

The beeper sound is stopped when the following conditions are met.

- When the full latch switch OFF and the latchet switch ON are detected.
- Vehicle speed of 1.2 mph (2 km/h) or less is detected.
- Close operation is stopped.

Warning Sound (4)

When the tailgate closing operation works, after the tailgate fall-down detection function activated two times.

Beeper

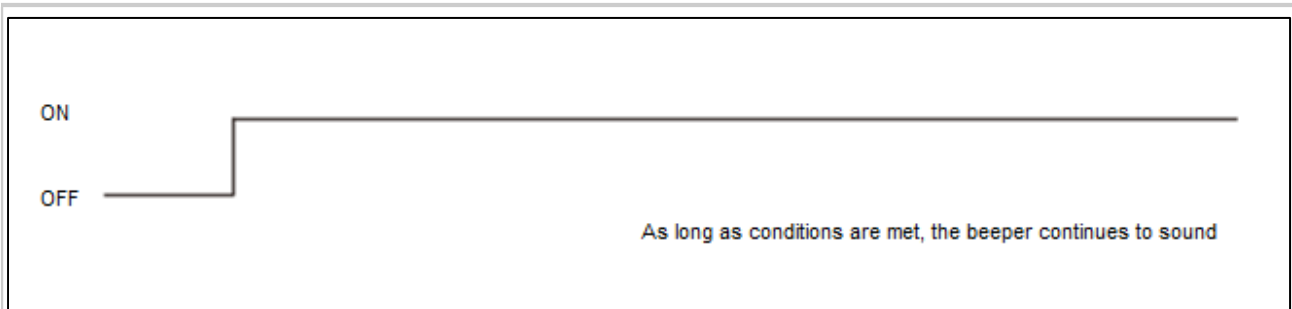

The beeper sound is stopped when the following conditions are met.

- When the full latch switch OFF or the half latch switch OFF is detected.
- Fall-down detection operation is stopped.

Warning Sound (5)

When the tailgate is not fully-latched, and the following condition is met: The shift lever is in any position/mode other than P, the brake pedal position switch, and the parking brake switch are OFF, and the vehicle speed exceeds 1.2 mph (2 km/h).

Beeper

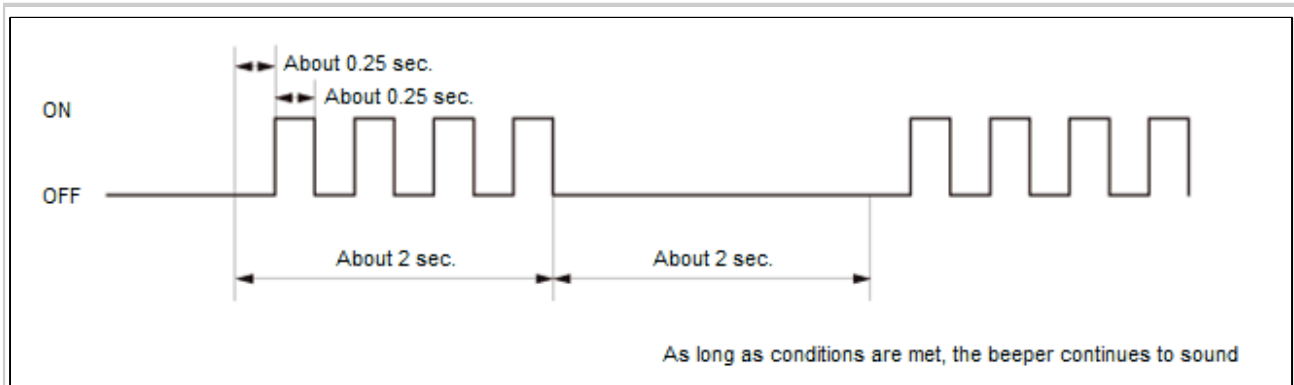

The beeper sound is stopped when the following conditions are met.

- 31 cycles of beeper sound is completed.
- Vehicle OFF (LOCK) mode.
- When the full latch switch OFF and the latchet switch ON is detected.
- Vehicle speed is 1.2 mph (2 km/h) or below and the P position/mode, the foot brake, or the parking brake are applied.

Warning Sound (6)

When the tailgate starts to open automatically. (when operating the tailgate outer handle switch within one second)

Beeper

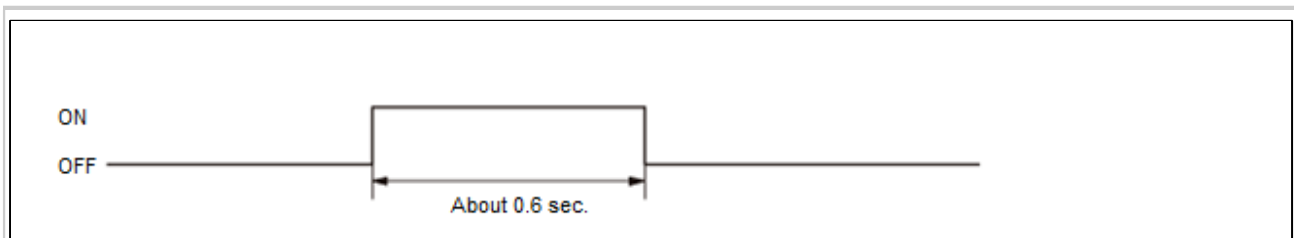

Warning Sound (7)

When the tailgate starts to open manually. (when operating the tailgate outer handle switch more than one second)

Beeper

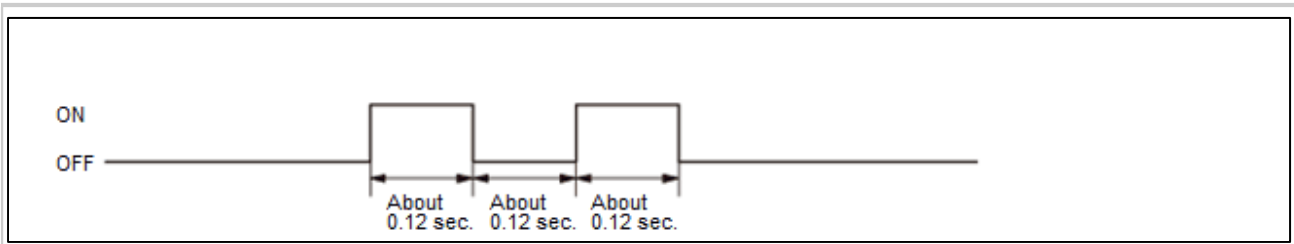

Courtesy of HONDA, U.S.A., INC.

Sector Gear Neutral Position Reset Control

The power tailgate closer unit operates normally (within standard) with the neutral switch OFF, so when starting an operation, it resets the sector gear to neutral position.

DESCRIPTION > POWER TAILGATE SYSTEM DESCRIPTION - FAILSAFE FUNCTION (2013-17)

A malfunction among the sensors, the switches, or the control units cancels the function of power tailgate as a failsafe. At the same time, the warning message on the gauge control module comes on.

DESCRIPTION > POWER TAILGATE SYSTEM DESCRIPTION - OVERVIEW (2013-15)

Operating one of the following a switch on the driver's power tailgate switch, the tailgate outer handle switch, or the power tailgate button on the remote, will open or close the tailgate.

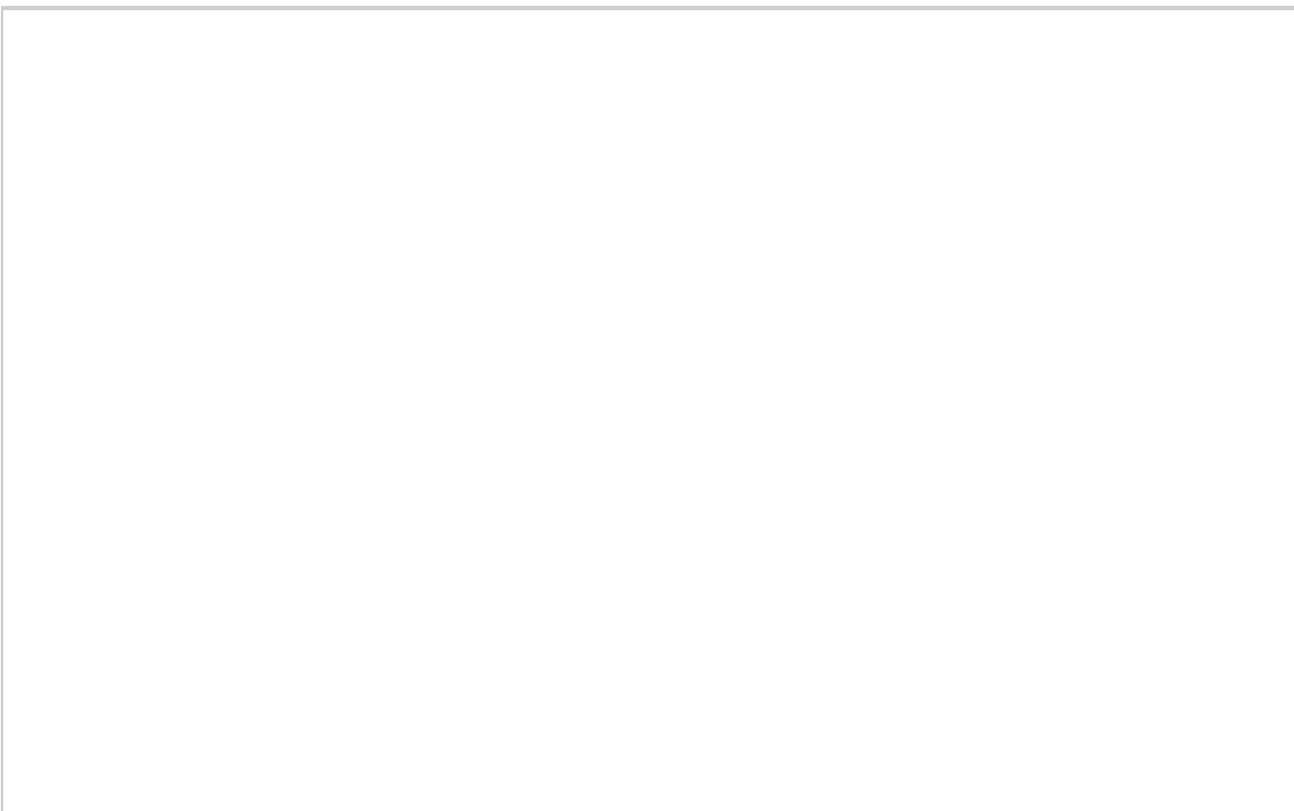

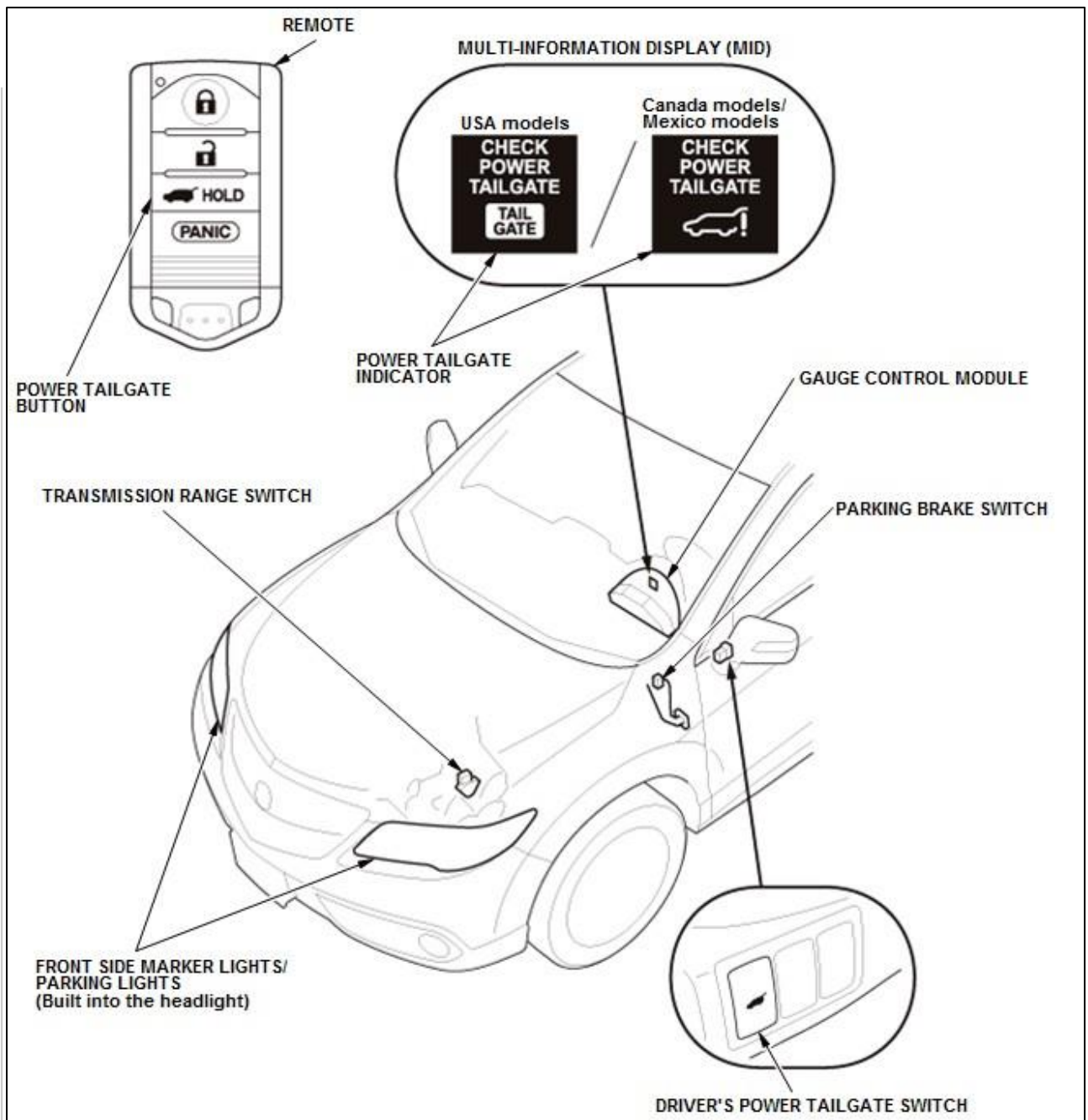

Courtesy of HONDA, U.S.A., INC.

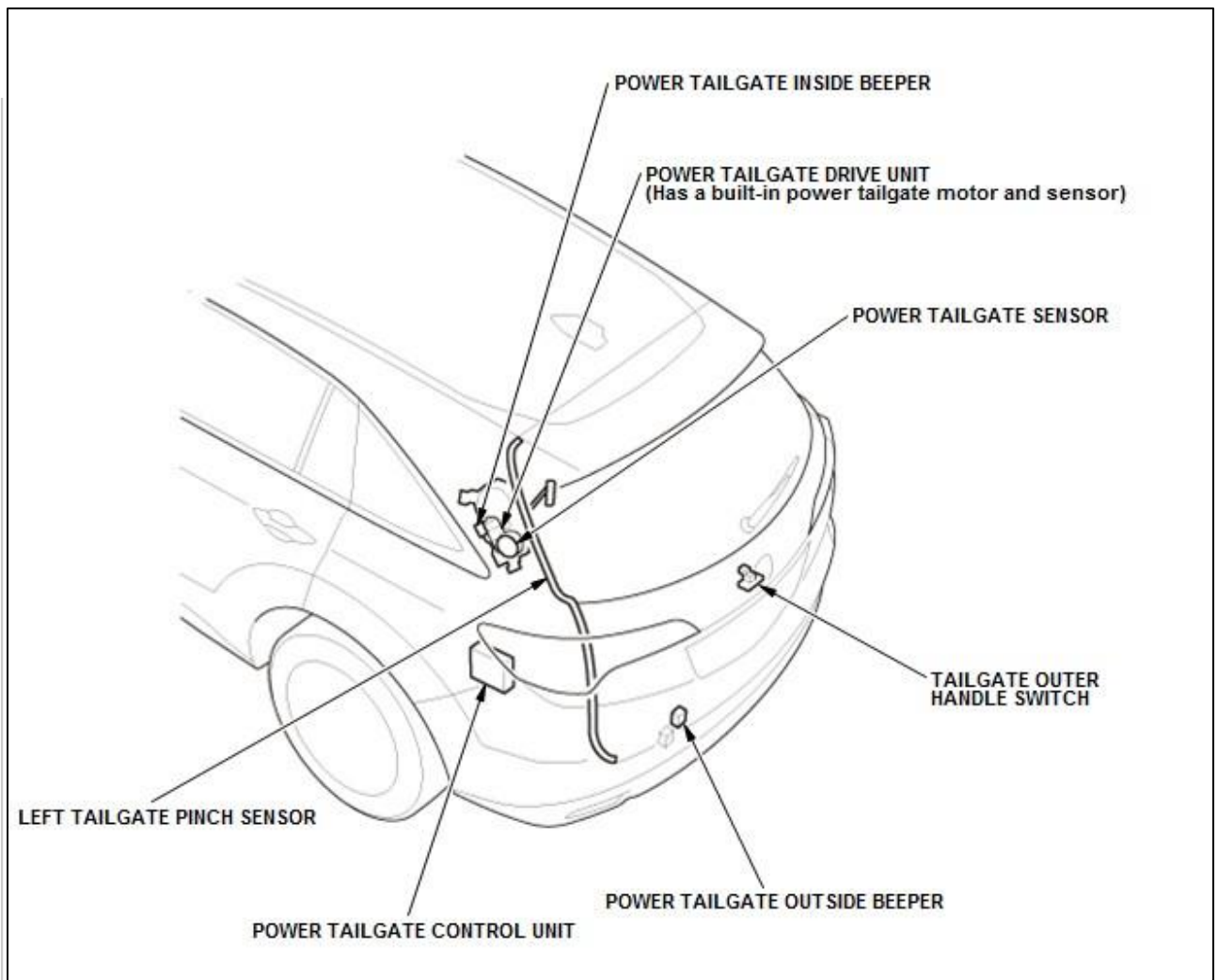

Courtesy of HONDA, U.S.A., INC.

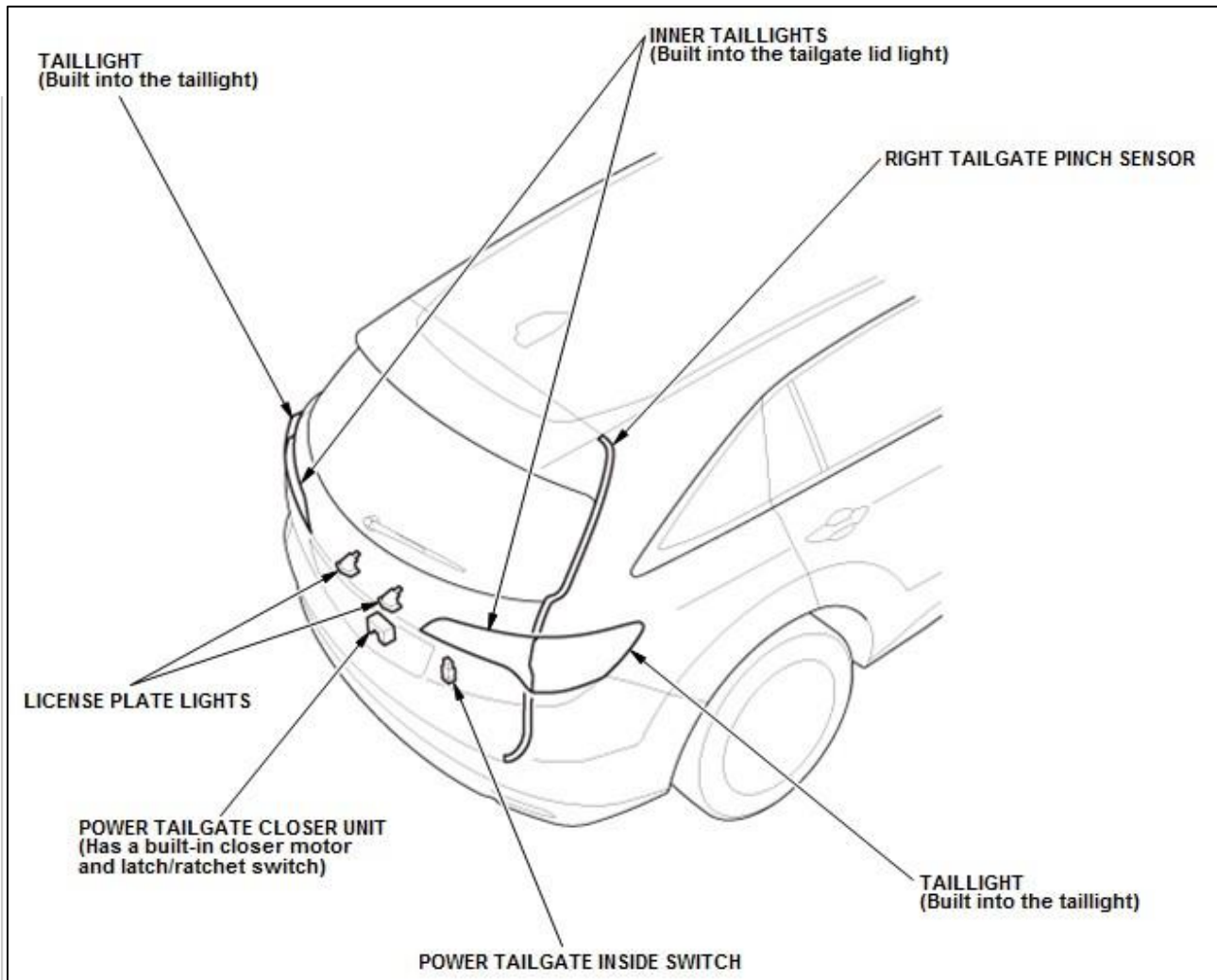

Courtesy of HONDA, U.S.A., INC.

DESCRIPTION > POWER TAILGATE SYSTEM DESCRIPTION - OVERVIEW (2016-17)

Operating one of the following switches, the driver's power tailgate switch, the tailgate outer handle switch, or the power tailgate button on the remote, will open or close the tailgate.

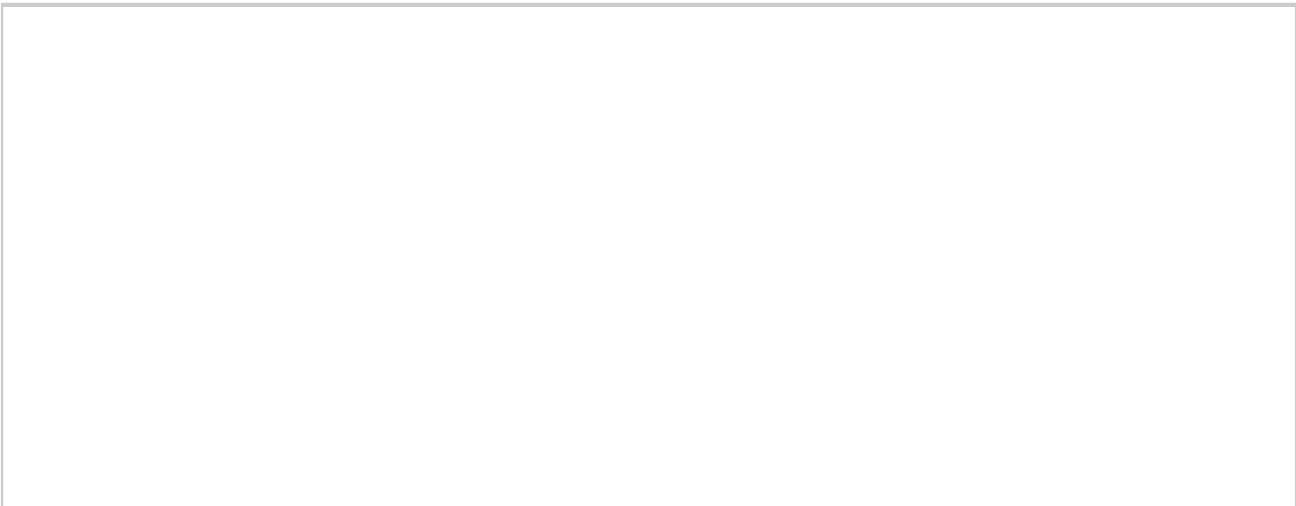

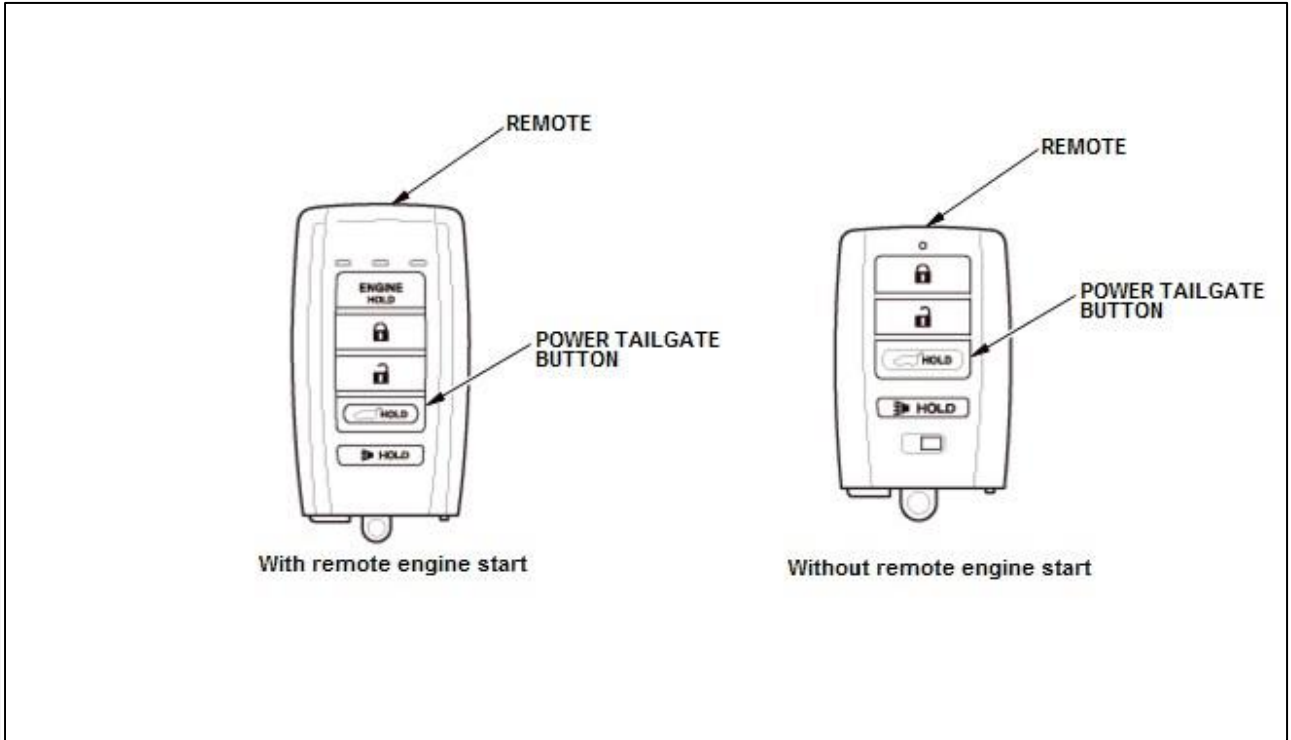

Courtesy of HONDA, U.S.A., INC.

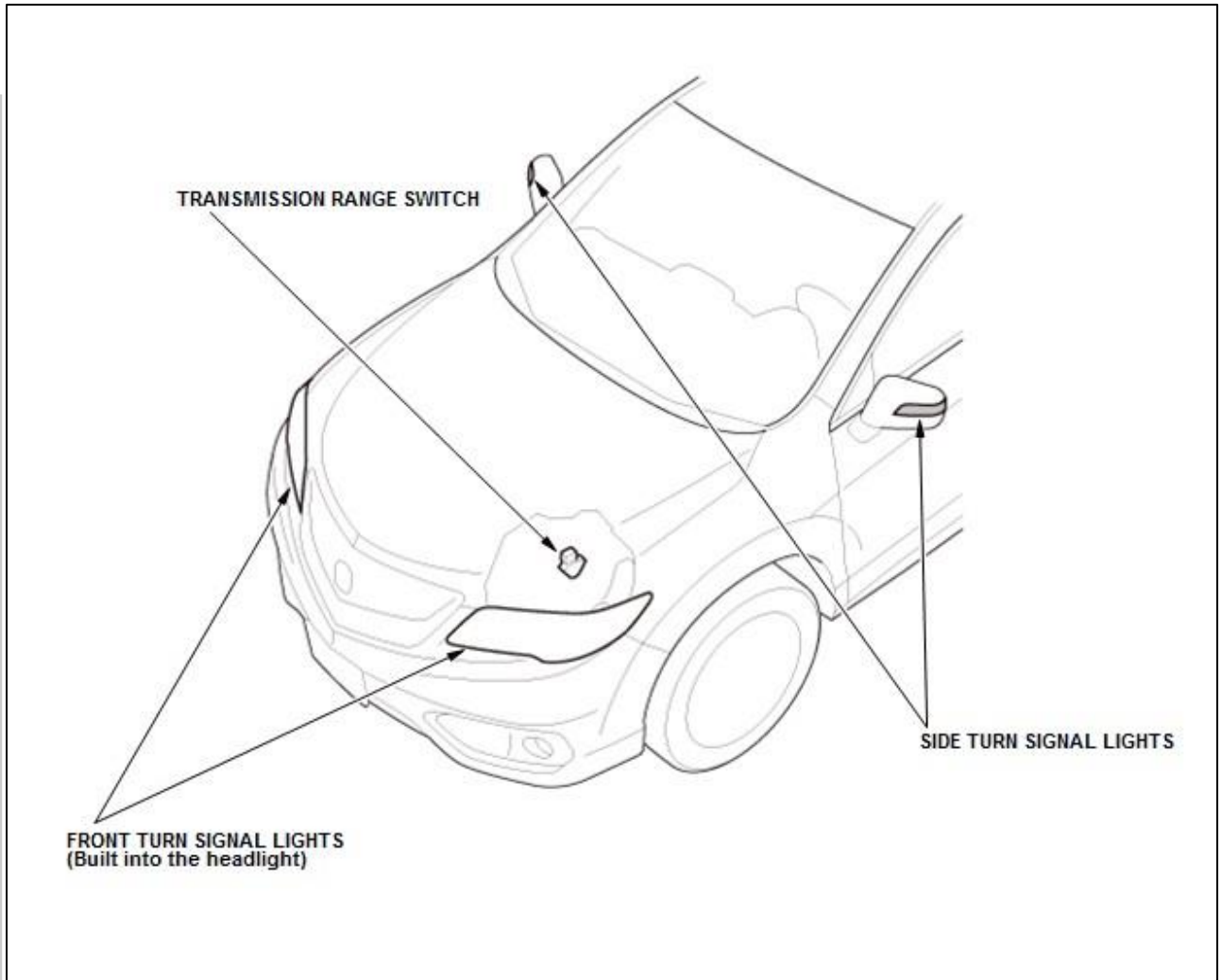

Courtesy of HONDA, U.S.A., INC.

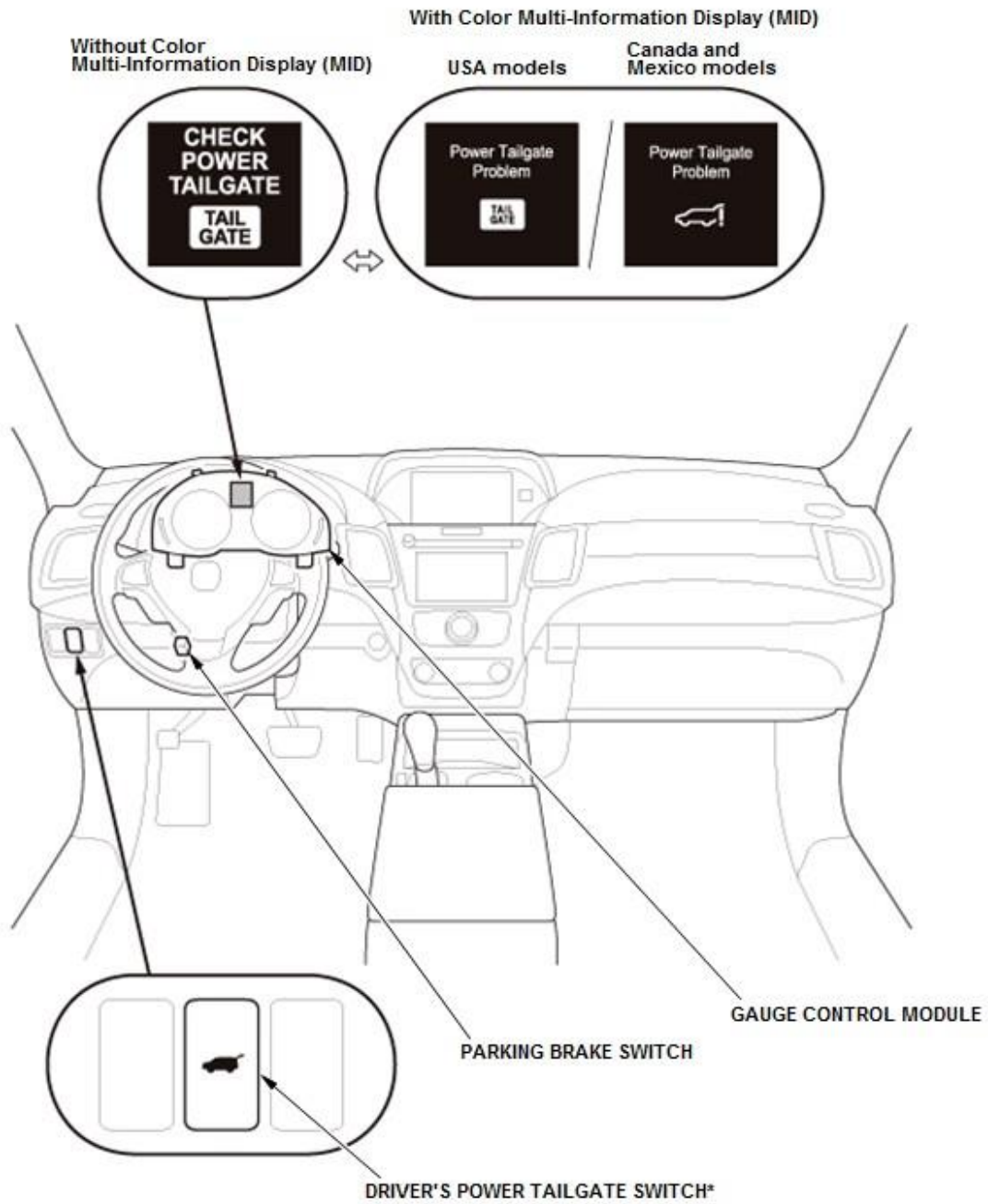

*: Location of the driver's power tailgate switch is different depending on the model.

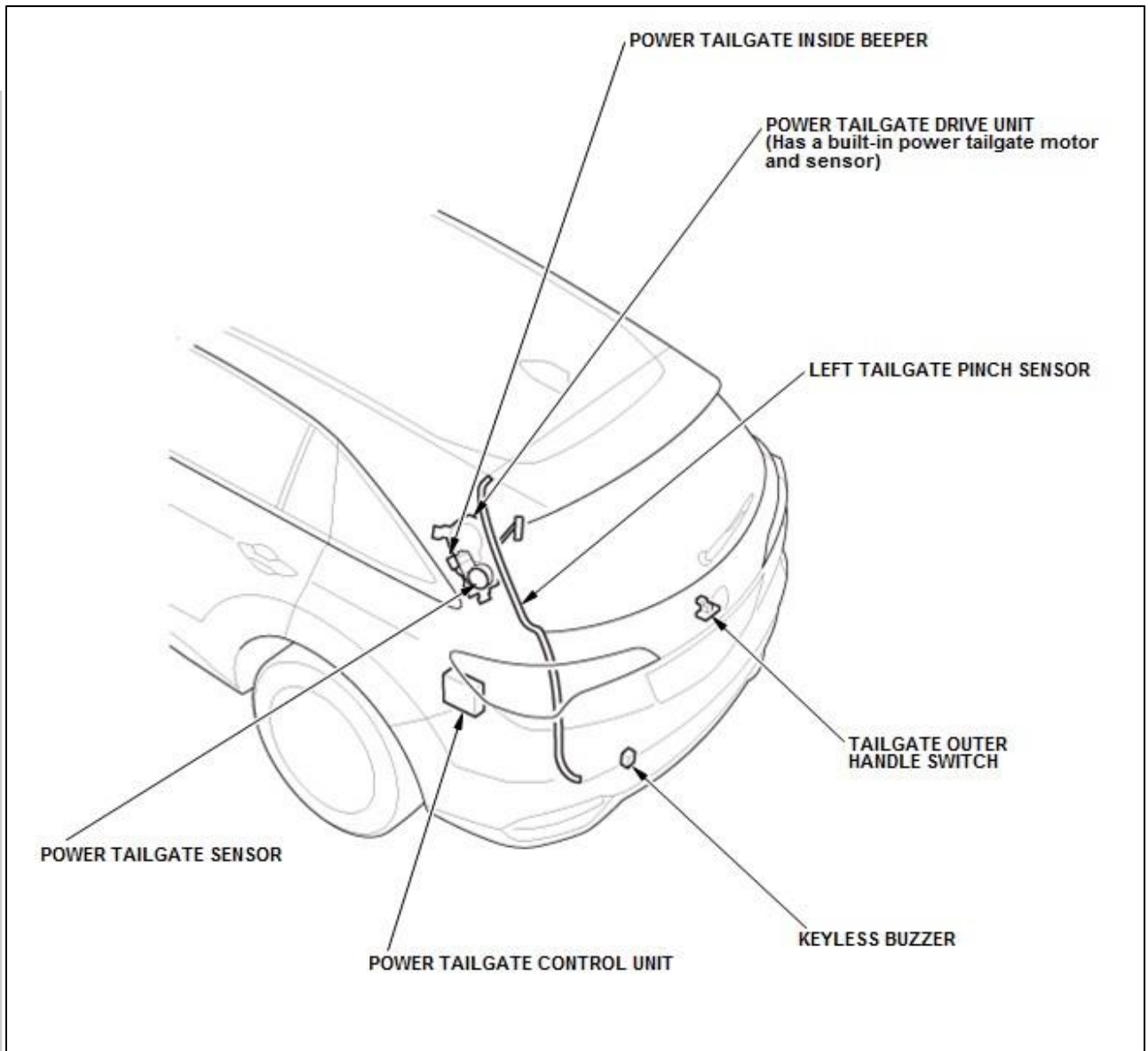

Courtesy of HONDA, U.S.A., INC.

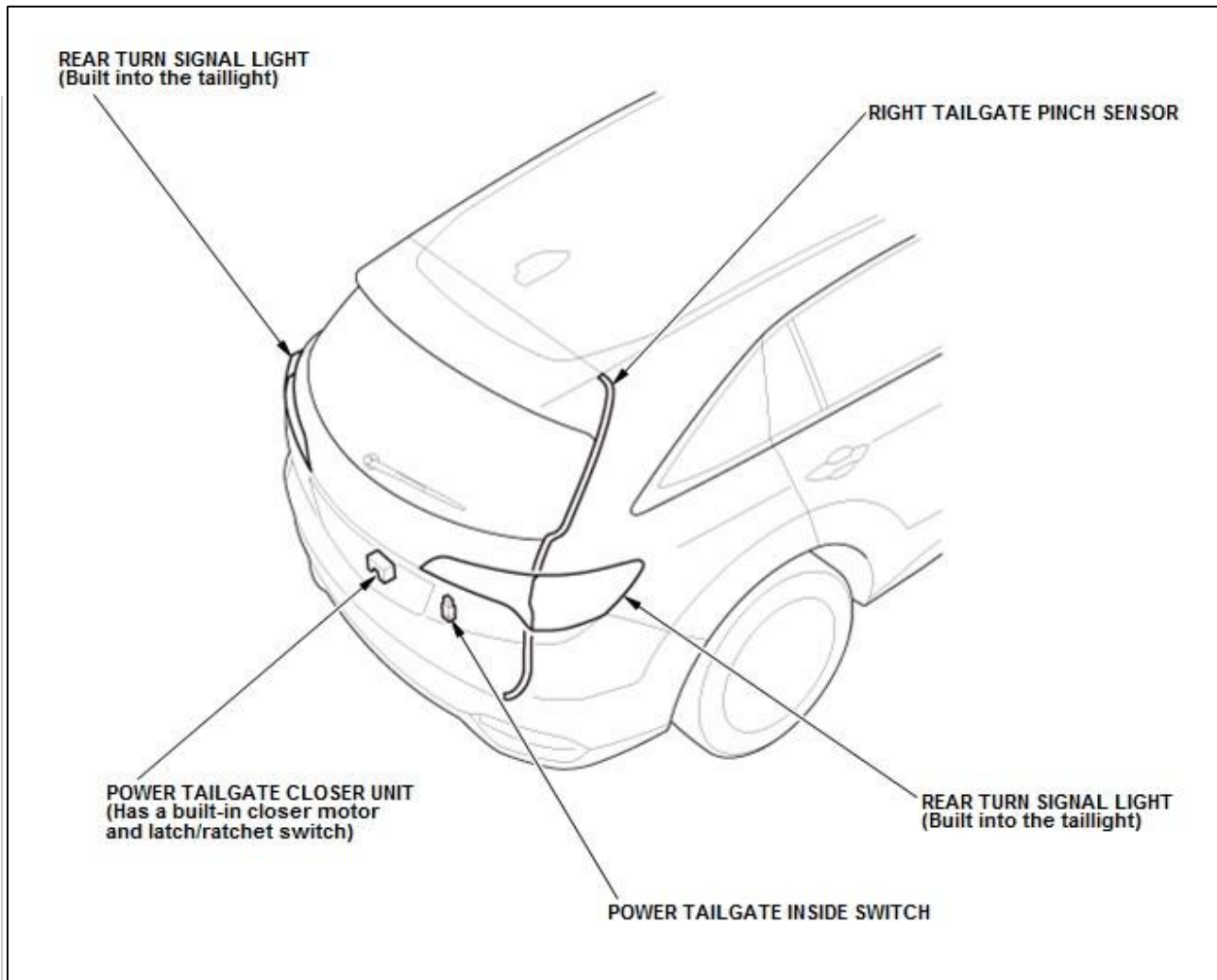

Courtesy of HONDA, U.S.A., INC.

**DESCRIPTION > POWER TAILGATE SYSTEM DESCRIPTION - SYSTEM DIAGRAM
(2013-15)**



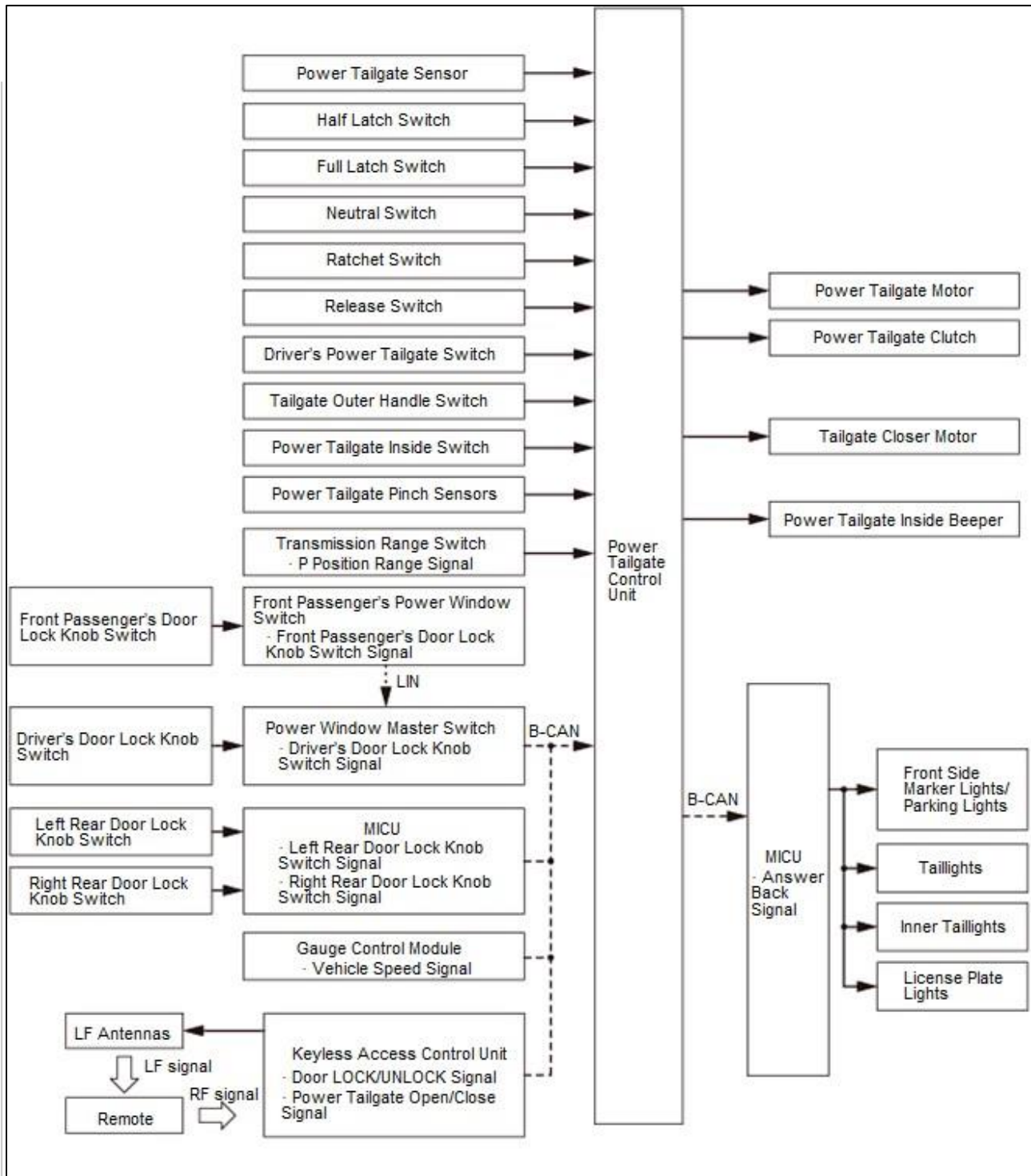

Courtesy of HONDA, U.S.A., INC.

DESCRIPTION > POWER TAILGATE SYSTEM DESCRIPTION - SYSTEM DIAGRAM (2016-17)

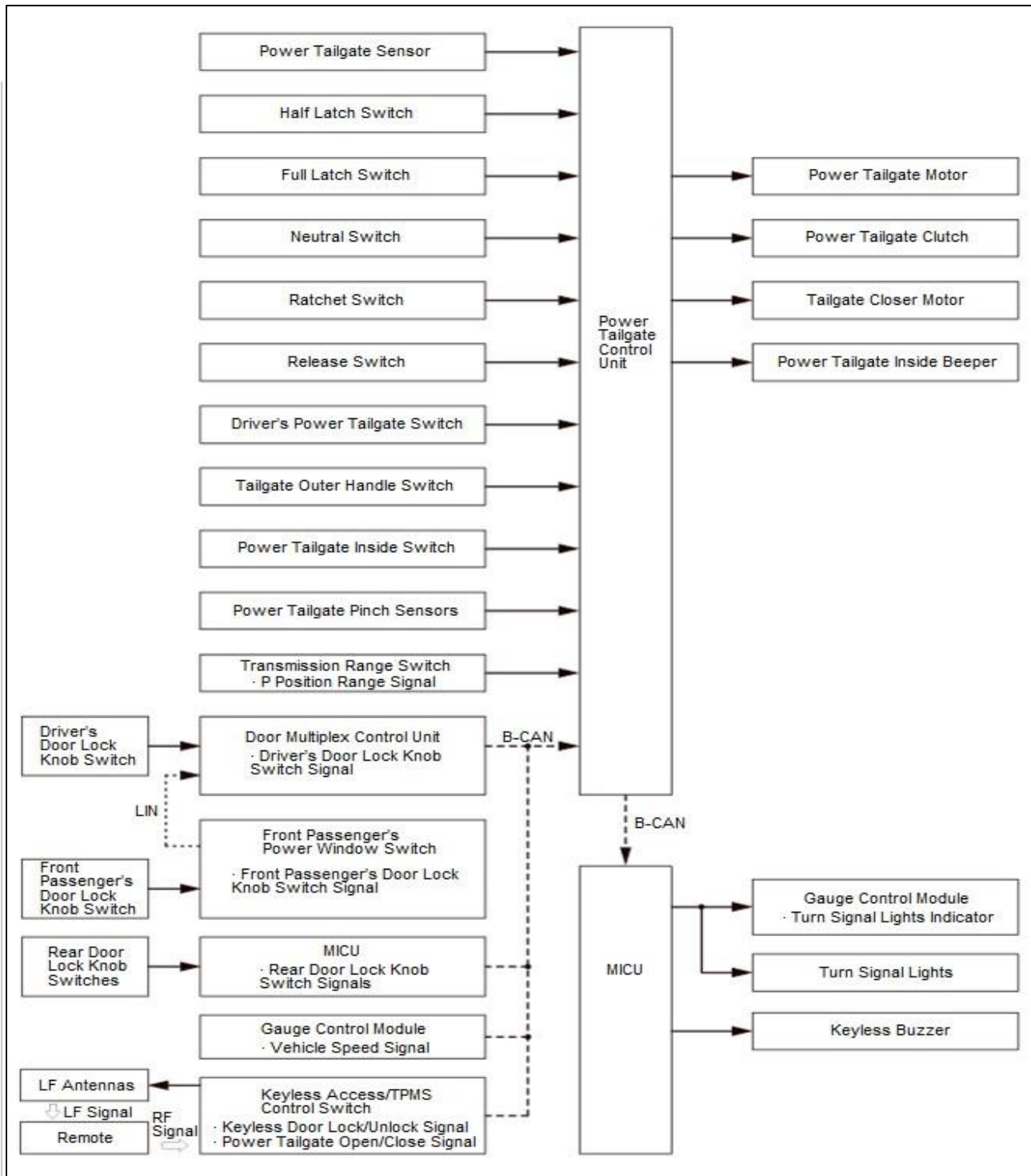

Courtesy of HONDA, U.S.A., INC.

TESTING > POWER TAILGATE CLOSER MOTOR TEST(WITH POWER TAILGATE) (2013-17) > TEST

1. Tailgate Lower Trim Panel - Remove



1. Remove the tailgate lower trim panel - Refer to: Interior Trim Removal and Installation - Cargo Areas (2013-17), or Interior Trim Removal and Installation - Pillar Areas (2013-17), or Interior Trim Removal and Installation - Rear Side Area (2013-17), or Interior Trim Removal and Installation - Tailgate Areas (2013-17), or Interior Trim Removal and Installation - Door Areas (2013-17) .

2. Power Tailgate Closer Motor - Test

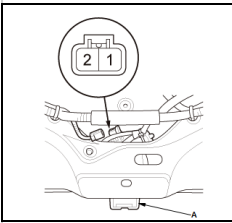

Courtesy of HONDA,
U.S.A., INC.

1. Disconnect power tailgate closer unit connector A.
2. Test the motor operation by connecting battery power to the tailgate closer unit connector A terminal No. 2 and ground to the terminal No. 1. To prevent damage to the motor, apply battery voltage only momentarily. The motor should run.
3. If the motor does not run or fails to run smoothly, the power tailgate closer motor is faulty; replace the tailgate latch assembly (A).
4. Connect power tailgate closer unit connector A.

3. Tailgate Lower Trim Panel - Install

1. Install the tailgate lower trim panel - Refer to: Interior Trim Removal and Installation - Cargo Areas (2013-17), or Interior Trim Removal and Installation - Pillar Areas (2013-17), or Interior Trim Removal and Installation - Rear Side Area (2013-17), or Interior Trim Removal and Installation - Tailgate Areas (2013-17), or Interior Trim Removal and Installation - Door Areas (2013-17) .

TESTING > POWER TAILGATE CONTROL UNIT INPUT TEST (2013-17)

NOTE:

- ◆ *Before testing, make sure the No. A1-5 (40 A), No. A13 (20 A), and No. A29 (10 A) fuses in the under-hood fuse/relay box are OK.*
- ◆ *Before testing, make sure the No. B5 (7.5 A) fuse in the under-dash fuse/relay box is OK.*
- ◆ *Before testing, check for DTCs. If any DTCs are indicated, troubleshoot those DTCs first.*

1. Press the engine start/stop button to select the OFF mode.
2. Disconnect the power tailgate control unit connectors .

NOTE: *All connector views are shown from the wire side of the female terminals.*

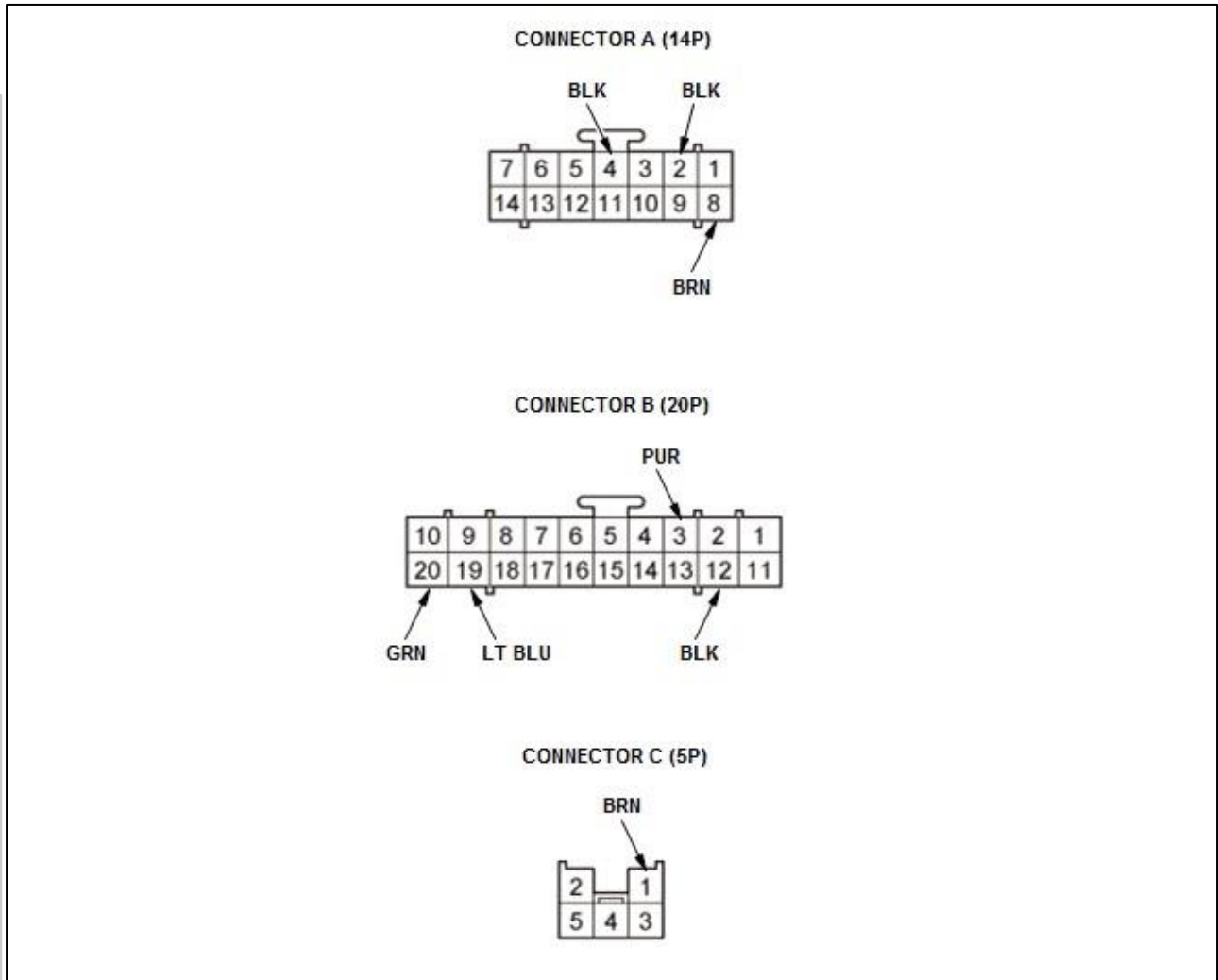

Courtesy of HONDA, U.S.A., INC.

3. Inspect the connectors and socket terminals to be sure they are all making good contact:
 - If the terminals are bent, loose, or corroded, repair them as necessary, and recheck the system.
 - If the terminals are OK, go to step 4.

4. Reconnect the connectors, and do the following input tests:
 - If any test indicates a problem, find and correct the cause, then recheck the system.
 - If all the input tests prove OK, replace the power tailgate control unit .

Cavity	Wire	Test condition	Test: Desired result	Possible cause if desired result is not obtained
C1	BRN	Under all conditions	Measure the voltage to ground: There should be battery voltage.	<ul style="list-style-type: none"> • Blown No. A1-5 (PTG MTR) (40 A) fuse in the under-hood fuse/relay box • An open or high resistance in the wire

B19	LT BLU	Under all conditions	Measure the voltage to ground:There should be battery voltage.	<ul style="list-style-type: none"> • Blown No. A13 (20 A) fuse in the under-hood fuse/relay box • An open or high resistance in the wire
B20	GRN	Under all conditions	Measure the voltage to ground:There should be battery voltage.	<ul style="list-style-type: none"> • Blown No. A29 (10 A) fuse in the under-hood fuse/relay box • Faulty under-dash fuse/relay box • An open or high resistance in the wire
A8	BRN	Power mode ON	Measure the voltage to ground:There should be battery voltage.	<ul style="list-style-type: none"> • Blown No. B5 (7.5 A) fuse in the under-dash fuse/relay box • An open or high resistance in the wire
A2	BLK	In all power modes	Measure the voltage to ground:There should be less than 0.2 V.	<ul style="list-style-type: none"> • Poor ground (G602) An • open or high resistance in the ground wire
A4	BLK	In all power modes	Measure the voltage to ground:There should be less than 0.2 V.	<ul style="list-style-type: none"> • Poor ground (G602) An • open or high resistance in the ground wire
B12	BLK	In all power modes	Measure the voltage to ground:There should be less than 0.2 V.	<ul style="list-style-type: none"> • Poor ground (G602) An • open or high resistance in the ground wire
B3	PUR	Shift lever in P position	Measure the voltage to ground:There should be less than 0.2 V.	<ul style="list-style-type: none"> • Faulty transmission range switch • Poor ground (G101) or an open in the ground wire • An open or high resistance in the wire
		Shift lever in any position other than P	Measure the voltage to ground:There should be about 5 V.	<ul style="list-style-type: none"> • Faulty transmission range switch

- A short to ground in the wire

**TESTING > POWER TAILGATE INSIDE SWITCH TEST(WITH POWER TAILGATE)
(2013-17) > TEST**

1. Power Tailgate Inside Switch Panel - Remove

1. Remove the power tailgate inside switch panel .

2. Power Tailgate Inside Switch - Test

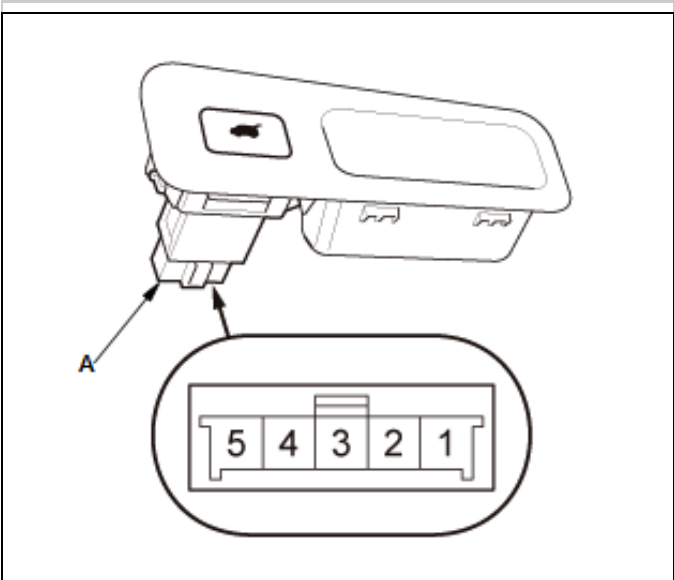

1. Check for continuity between the terminals in each switch position according to the table.
2. If the continuity is not as specified, replace the bulb or the power tailgate inside switch (A).

Terminal Position	2	3		4	5
ON	○	⊕	○	○	○
OFF	○	⊕	○		

Courtesy of HONDA, U.S.A., INC.HONDA, U.S.A., INC.

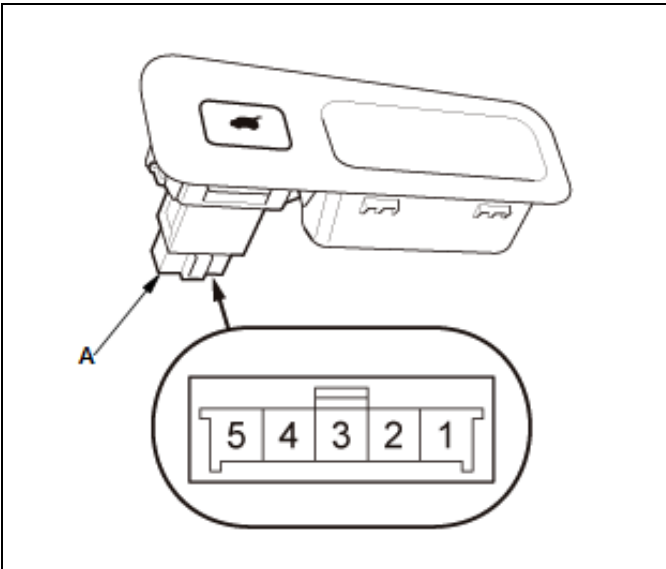

Terminal Position	2	3		4	5
ON	○	⊗	○	○	○
OFF	○	⊗	○		

Courtesy of HONDA, U.S.A., INC. HONDA, U.S.A., INC.

3. Power Tailgate Inside Switch Panel - Install

1. Install the power tailgate inside switch panel .

TESTING > POWER TAILGATE LATCH/RATCHET SWITCH TEST(WITH POWER TAILGATE) (2013-17) > TEST

1. Tailgate Lower Trim Panel - Remove

1. Remove the tailgate lower trim panel - Refer to: Interior Trim Removal and Installation - Cargo Areas (2013-17), or Interior Trim Removal and Installation - Pillar Areas (2013-17), or Interior Trim Removal and Installation - Rear Side Area (2013-17), or Interior Trim Removal and Installation - Tailgate Areas (2013-17), or Interior Trim Removal and Installation - Door Areas (2013-17) .

2. Power Tailgate Latch/Ratchet Switch - Test

1. Disconnect power tailgate closer unit connector B.
2. Check for continuity between the terminals in each switch position according to the table.
3. If the continuity is not specified, the tailgate latch switch is faulty; replace the tailgate latch assembly (A).

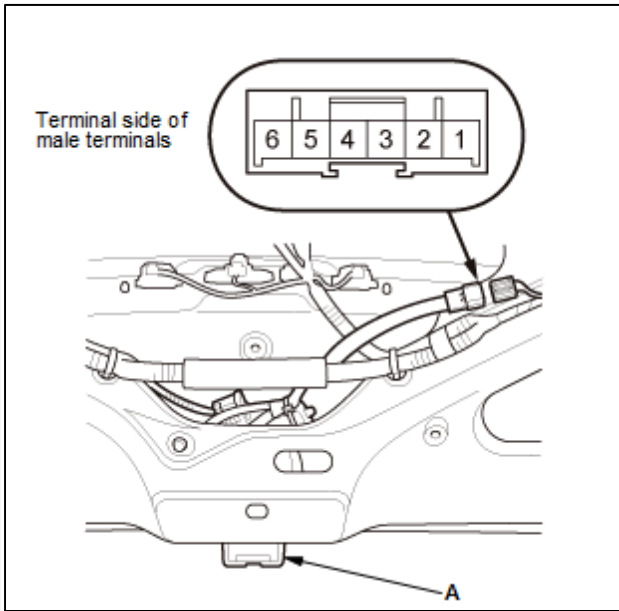

4. Connect power tailgate closer unit connector B.

Terminal Position	B6	B3	B5	B4
Full latched	○	○		
Between the fully-latched position to released position	○	○	○	
Released	○		○	○

Courtesy of HONDA, U.S.A., INC. HONDA, U.S.A., INC.

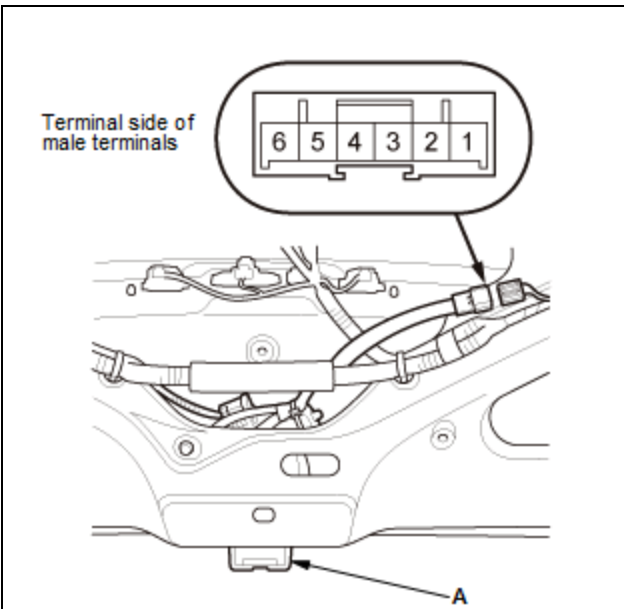

Terminal Position	B6	B3	B5	B4
Full latched	○	○		
Between the fully-latched position to released position	○	○	○	
Released	○		○	○

Courtesy of HONDA, U.S.A., INC. HONDA, U.S.A., INC.

3. Tailgate Lower Trim Panel - Install

1. Install the tailgate lower trim panel - Refer to: Interior Trim Removal and Installation - Cargo Areas (2013-17), or Interior Trim Removal and Installation - Pillar Areas (2013-17), or Interior Trim Removal and Installation - Rear Side Area (2013-17), or Interior Trim Removal and Installation - Tailgate Areas (2013-17), or Interior Trim Removal and Installation - Door Areas (2013-17) .

TESTING > POWER TAILGATE MOTOR TEST(WITH POWER TAILGATE) (2013-17) > TEST

NOTE: *The motor and the clutch are built into the drive unit.*

1. Quarter Pillar Trim Panel - Remove

1. Remove the left quarter pillar trim panel - Refer to: Interior Trim Removal and Installation - Cargo Areas (2013-17), or Interior Trim Removal and Installation - Pillar Areas (2013-17), or Interior Trim Removal and Installation - Rear Side Area (2013-17), or Interior Trim Removal and Installation - Tailgate Areas (2013-17), or Interior Trim Removal and Installation - Door Areas (2013-17) .

2. Power Tailgate Clutch - Test

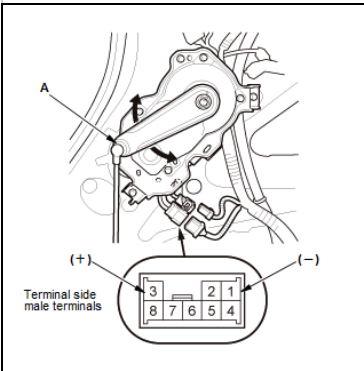

Courtesy of HONDA, U.S.A., INC.

NOTE: While doing the test, do not reinstall the arm bracket.

1. Disconnect these connectors:
 1. Power tailgate drive unit connector A
 2. Power tailgate drive unit connector B
2. Check the moving arm (A) for moving smoothly by hand.
3. Connect power tailgate drive unit connector B terminal No. B3 to battery power and terminal No. B1 to ground.
4. Check that arm does not move while applying voltage. If the arm moves, the clutch is faulty; replace the power tailgate drive unit .

NOTE: After testing, remove the applying voltage.

3. Power Tailgate Motor - Test

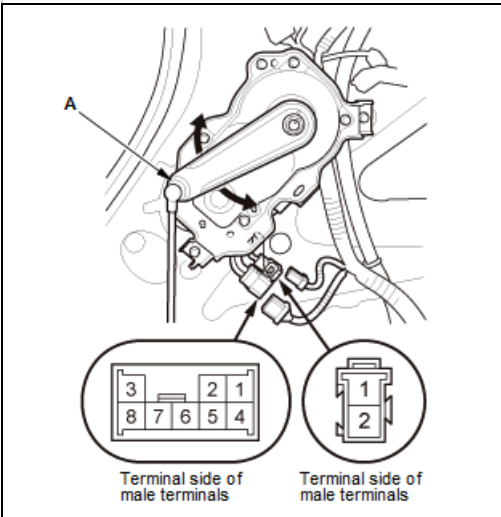

Terminal	1	2
Direction		
Open	⊕	⊖
Closed	⊖	⊕

Courtesy of HONDA, U.S.A., INC.HONDA, U.S.A., INC.

1. Set the arm (A) to the center of the operation range as shown.
2. Operate the power tailgate clutch by connecting power tailgate drive unit connector B terminal No. B3 to battery power and terminal No. B1 to ground.
3. Test the power tailgate motor by connecting power and ground according to the table. When the motor stops running, disconnect battery power immediately.

NOTE: While testing the motor, apply voltage for less than 1 second.

4. Check the motor runs smoothly. If the motor does not run or fails to run smoothly, replace the power tailgate drive unit .

NOTE: After testing, remove the applying voltage.

5. Connect these connectors:
 1. Power tailgate drive unit connector A

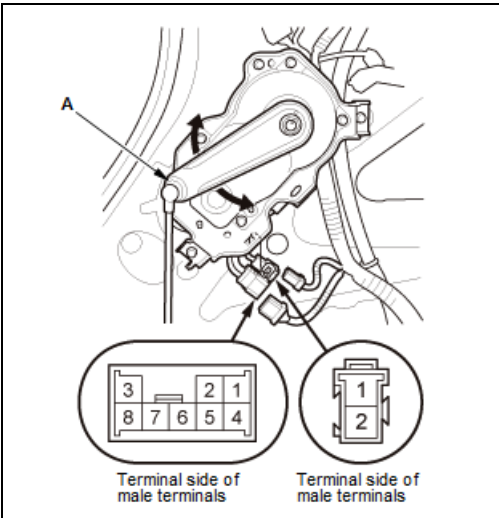

2. Power tailgate drive unit connector B

Terminal	1	2
Direction		
Open	⊕	⊖
Closed	⊖	⊕

Courtesy of HONDA, U.S.A., INC. HONDA, U.S.A., INC.

4. Quarter Pillar Trim Panel - Install

1. Install the left quarter pillar trim panel - Refer to: Interior Trim Removal and Installation - Cargo Areas (2013-17), or Interior Trim Removal and Installation - Pillar Areas (2013-17), or Interior Trim Removal and Installation - Rear Side Area (2013-17), or Interior Trim Removal and Installation - Tailgate Areas (2013-17), or Interior Trim Removal and Installation - Door Areas (2013-17) .

TESTING > POWER TAILGATE PINCH SENSOR TEST(WITH POWER TAILGATE) (2013-17) > TEST

1. Tailgate Upper Trim Panel - Remove

1. Remove the tailgate upper trim panel - Refer to: Interior Trim Removal and Installation - Cargo Areas (2013-17), or Interior Trim Removal and Installation - Pillar Areas (2013-17), or Interior Trim Removal and Installation - Rear Side Area (2013-17), or Interior Trim Removal and Installation - Tailgate Areas (2013-17), or Interior Trim Removal and Installation - Door Areas (2013-17) .

2. Power Tailgate Pinch Sensor - Test

1. Disconnect the power tailgate pinch sensor connector.
2. Measure the resistance between the pinch sensor connector terminals No. 1 and No. 2. The resistance should vary from about 1 kΩ to about 100 Ω when the sensor is pressed.
3. If the resistance is not as specified, replace the pinch sensor (A).
4. Connect the power tailgate pinch sensor connector.

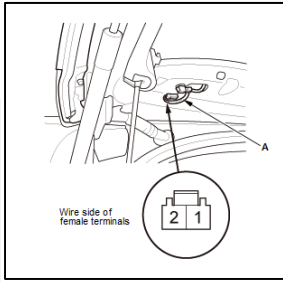

Courtesy of HONDA, U.S.A.,
INC.

3. Tailgate Upper Trim Panel - Install

1. Install the tailgate upper trim panel - Refer to: Interior Trim Removal and Installation - Cargo Areas (2013-17), or Interior Trim Removal and Installation - Pillar Areas (2013-17), or Interior Trim Removal and Installation - Rear Side Area (2013-17), or Interior Trim Removal and Installation - Tailgate Areas (2013-17), or Interior Trim Removal and Installation - Door Areas (2013-17) .

TESTING > POWER TAILGATE SENSOR TEST(WITH POWER TAILGATE) (2013-17) > TEST

1. Quarter Pillar Trim Panel - Remove

1. Remove the left quarter pillar trim panel - Refer to: Interior Trim Removal and Installation - Cargo Areas (2013-17), or Interior Trim Removal and Installation - Pillar Areas (2013-17), or Interior Trim Removal and Installation - Rear Side Area (2013-17), or Interior Trim Removal and Installation - Tailgate Areas (2013-17), or Interior Trim Removal and Installation - Door Areas (2013-17) .

2. Power Tailgate Sensor - Test

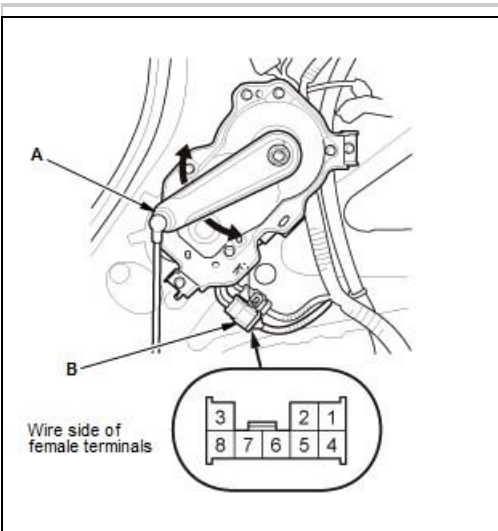

1. Measure the voltage between the drive unit connector B terminals as shown.
PTG/PTL SVCC circuit

Courtesy of HONDA, U.S.A., INC.

Drive unit connector B	
No. B8	No. B4

1. If there is about 10 V, go to step 3.
 2. If there is no voltage, go to power tailgate control unit input test terminals No. A9, No. B13, No. B16, and No. B17 .
2. Measure the voltage between drive unit connector B terminals as shown while the arm unit (A) moves. An analog voltmeter should alternate between 0 V and about 5 V (a digital voltmeter should read about 2.5 V).

PTG/PTL SENA and PTG/PTL SENB circuits

Drive unit connector B	
No. B7	No. B4
No. B6	No. B4

1. If the voltage is as specified and the wire is OK, replace the power tailgate control unit .
2. If the voltage is not specified, replace the power tailgate sensor .

3. Quarter Pillar Trim Panel - Install

1. Install the left quarter pillar trim panel - Refer to: Interior Trim Removal and Installation - Cargo Areas (2013-17), or Interior Trim Removal and Installation - Pillar Areas (2013-17), or Interior Trim Removal and Installation - Rear Side Area (2013-17), or Interior Trim Removal and Installation - Tailgate Areas (2013-17), or Interior Trim Removal and Installation - Door Areas (2013-17) .
--