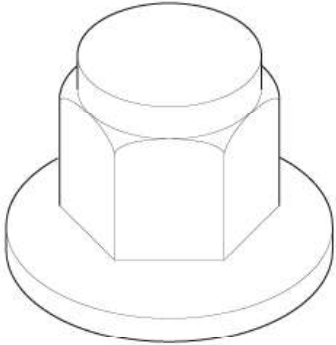
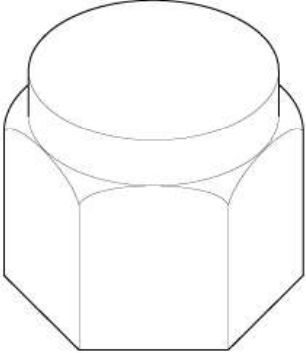

YMMS: 2018 Acura RDX Base
Engine: 3.5L Eng
VIN:

Nov 2, 2020
License:
Odometer:

REMOVAL / INSTALLATION > BALL JOINT REMOVAL (2013-18)

Special Tools Required

Image	Description/Tool Number
 <p>A technical line drawing of a 14 mm ball joint thread protector. It consists of a hexagonal nut with a cylindrical top and a wider, flat circular base.</p>	<p>Ball Joint Thread Protector, 14 mm 071AF-SZNA100</p>
<p>Courtesy of HONDA, U.S.A., INC.</p>	
 <p>A technical line drawing of a 12 mm ball joint thread protector. It consists of a hexagonal nut with a cylindrical top and a wider, flat circular base.</p>	<p>Ball Joint Thread Protector, 12 mm 07AAF-SDAA100</p>
<p>Courtesy of HONDA, U.S.A., INC.</p>	
	<p>Ball Joint Remover, 32 mm 07MAC-SL00102</p>

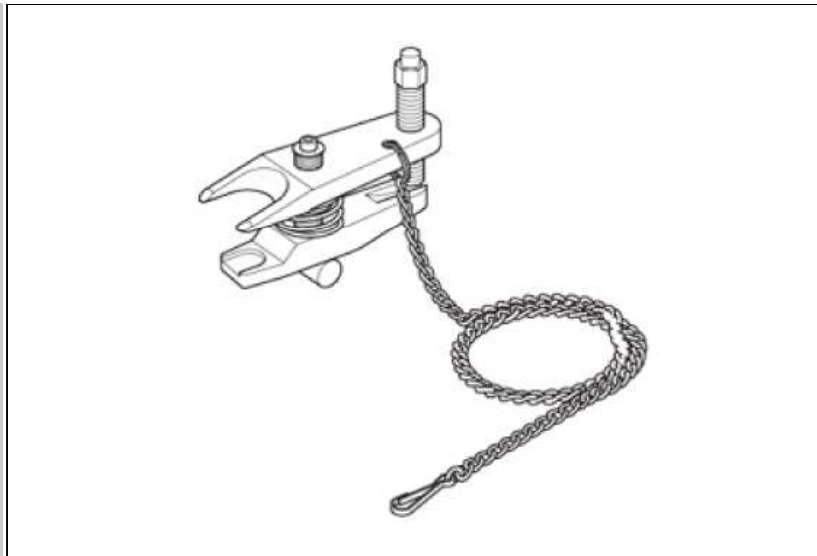

Courtesy of HONDA, U.S.A., INC.

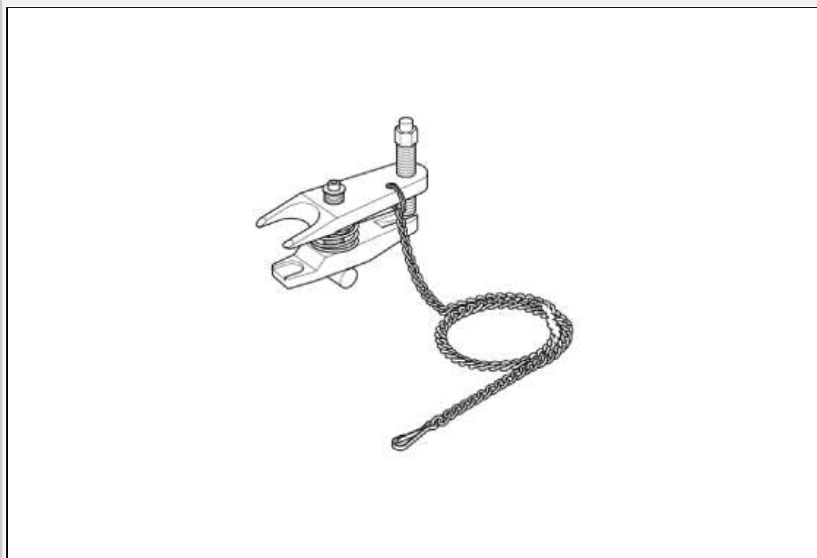

Courtesy of HONDA, U.S.A., INC.

Ball Joint Remover, 28 mm 07MAC-SL00202

REMOVAL / INSTALLATION > BALL JOINT REMOVAL (2013-18) > REMOVAL



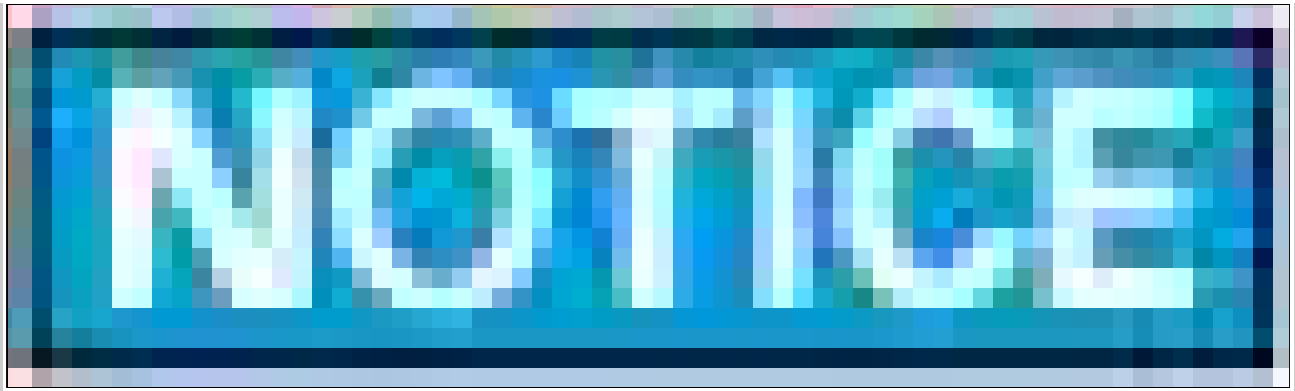

Courtesy of HONDA, U.S.A., INC.

Always use a ball joint remover to disconnect a ball joint. Do not strike the housing or any other part of the ball joint connection to disconnect it.

1. Ball Joint - Removal

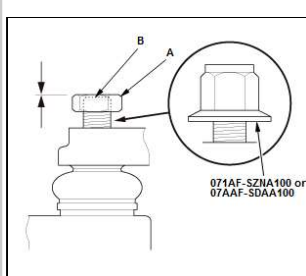

Courtesy of HONDA, U.S.A., INC.

1. Install a hex nut (A) or the ball joint thread protector onto the threads of the ball joint (B).

NOTE: When using a hex nut, make sure the nut is flush with the ball joint pin end to prevent damage to the threaded end of the ball joint pin.

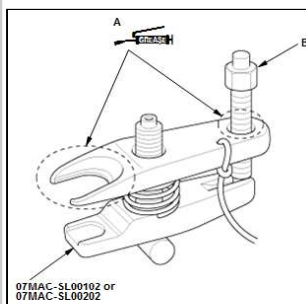

Courtesy of HONDA, U.S.A., INC.

2. Apply grease to the ball joint remover on the areas as shown (A). This will ease the installation of the tool, and prevent damage to the pressure bolt (B) threads.

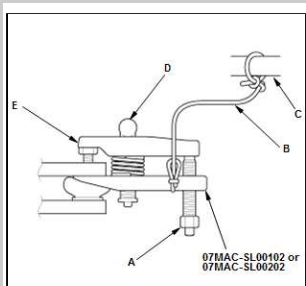

Courtesy of HONDA, U.S.A., INC.

3. Loosen the pressure bolt (A), and install the ball joint remover as shown.

NOTE:

1. Insert the jaws carefully, making sure not to damage the ball joint boot.
2. Fasten the safety tie (B) securely to a suspension arm or the subframe (C). Do

Courtesy of HONDA, U.S.A.,
INC.

*not fasten it to a brake line or wire
harness.*

4. Adjust the jaw spacing by turning the adjusting bolt (D)
5. Make sure the head of the adjusting bolt is in the position shown to allow the jaw (E) to pivot
6. Tighten the pressure bolt until the ball joint pin pops loose from the ball joint connecting hole. If necessary, apply penetrating type lubricant to loosen the ball joint pin.



NOTE: *Do not use pneumatic or electric
tools on the pressure bolt*

7. Remove the ball joint remover
8. Remove the nut or the ball joint thread protector
9. Pull the ball joint out of the ball joint connecting hole
10. Inspect the ball joint boot, and replace it if damaged.

REMOVAL / INSTALLATION > FRONT DAMPER/SPRING REMOVAL AND INSTALLATION (2013-15) > REMOVAL

1. Vehicle - Lift

1. Raise and support the vehicle .

2. Front Wheel - Remove

1. Remove the front wheel .

3. Damper/Spring Items - Remove

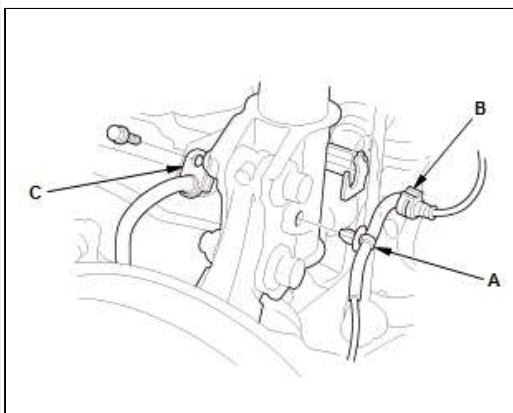

Courtesy of HONDA, U.S.A., INC.

1. Remove the wheel speed sensor harness clip (A) and the wire guide (B).



NOTE: *Do not disconnect the
wheel speed sensor connector*

2. Remove the brake hose bracket (C).

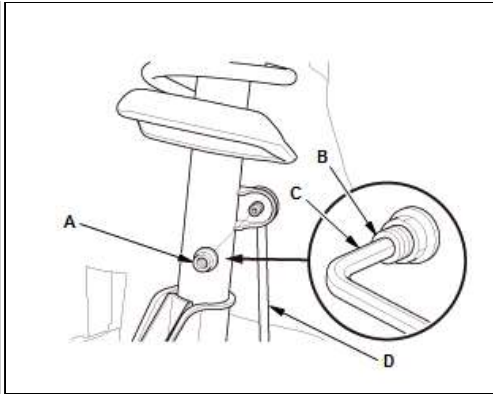

3. Remove the flange nut (A) while holding the joint pin (B) with a hex wrench (C)
4. Disconnect the stabilizer link (D) from the damper.

Courtesy of HONDA, U.S.A., INC.

4. Damper/Spring - Remove

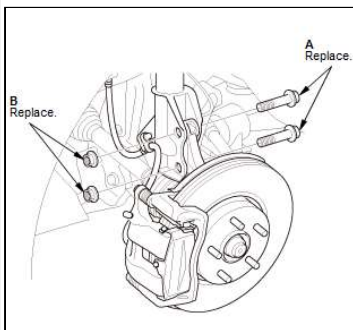

Courtesy of HONDA, U.S.A., INC.

1. Remove the damper pinch bolts (A) and the flange nuts (B).

NOTE: Do not allow the knuckle to rotate too far outward. This may allow the driveshaft inboard joint to come apart.

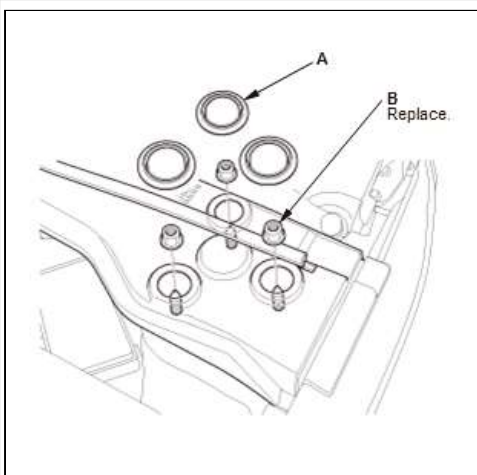

Courtesy of HONDA, U.S.A., INC.

2. Remove the service caps (A)
3. Remove the flange nuts (B).

NOTE: Do not let the damper/spring drop down under its own weight.

4. Remove the damper/spring (A).

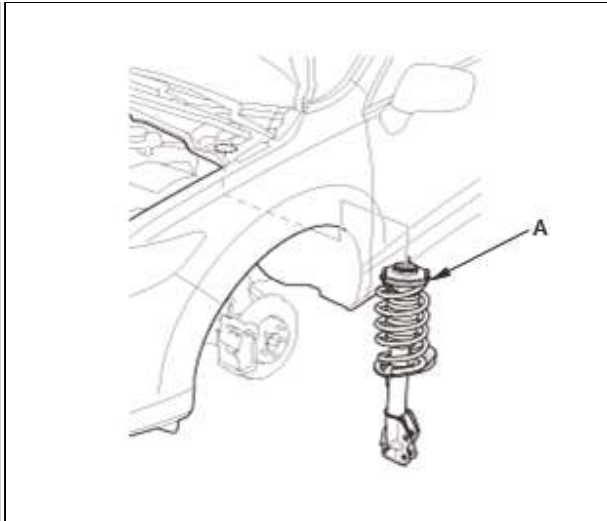

Courtesy of HONDA, U.S.A., INC.

 **NOTE:** Be careful not to damage the body.

REMOVAL / INSTALLATION > FRONT DAMPER/SPRING REMOVAL AND INSTALLATION (2013-15) > INSTALLATION

1. Damper/Spring - Install

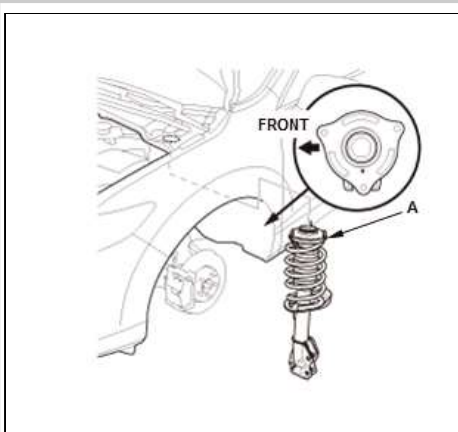

Courtesy of HONDA, U.S.A., INC.

1. Install the damper/spring (A). Note the direction of the damper mounting base as shown.

 **NOTE:** Be careful not to damage the body.

Fig 1: Damper Nut With Torque Specifications

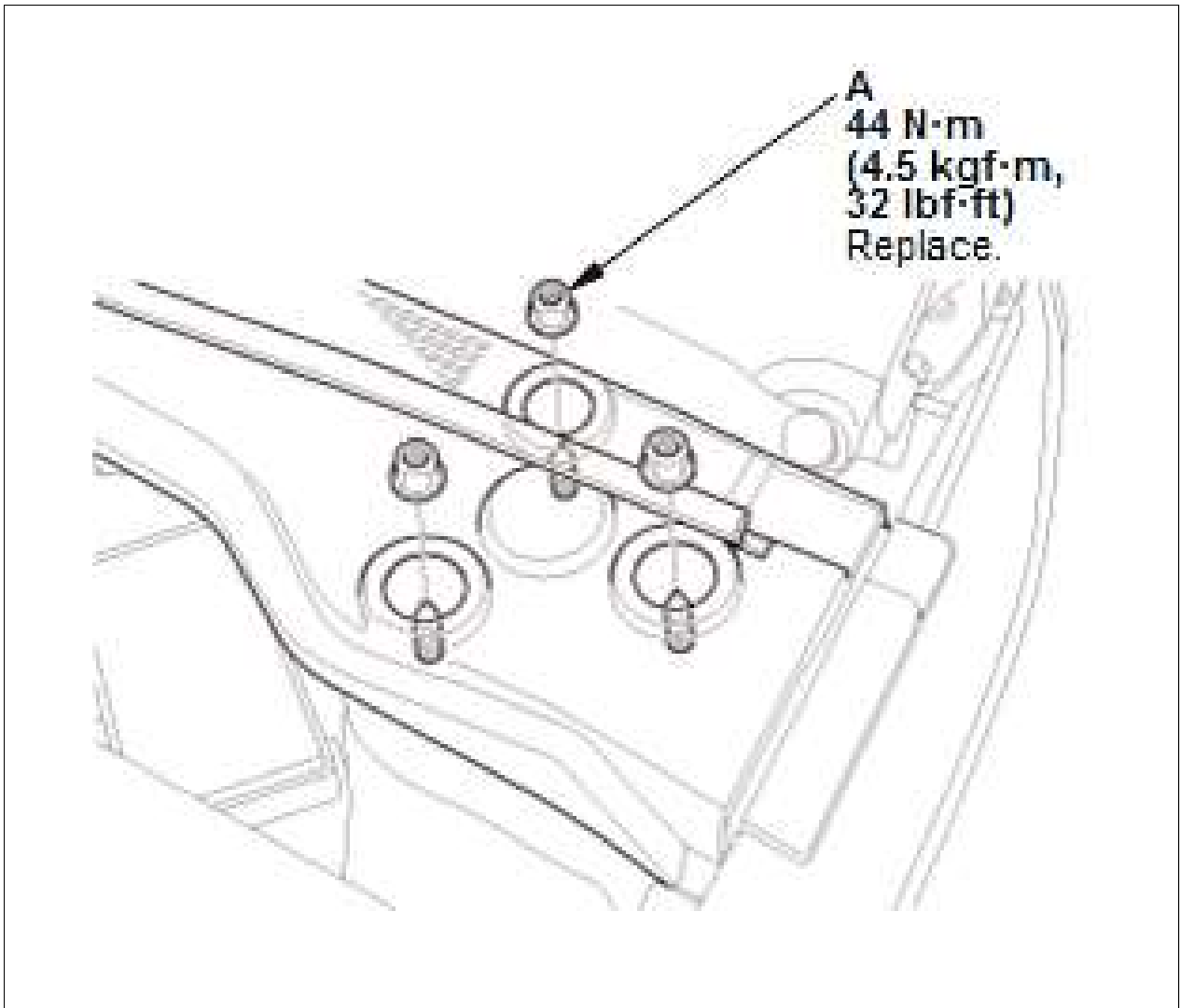

Courtesy of HONDA, U.S.A., INC.

2. Loosely install the new flange nuts (A).

Fig 2: Damper Pinch Bolts With Torque Specifications

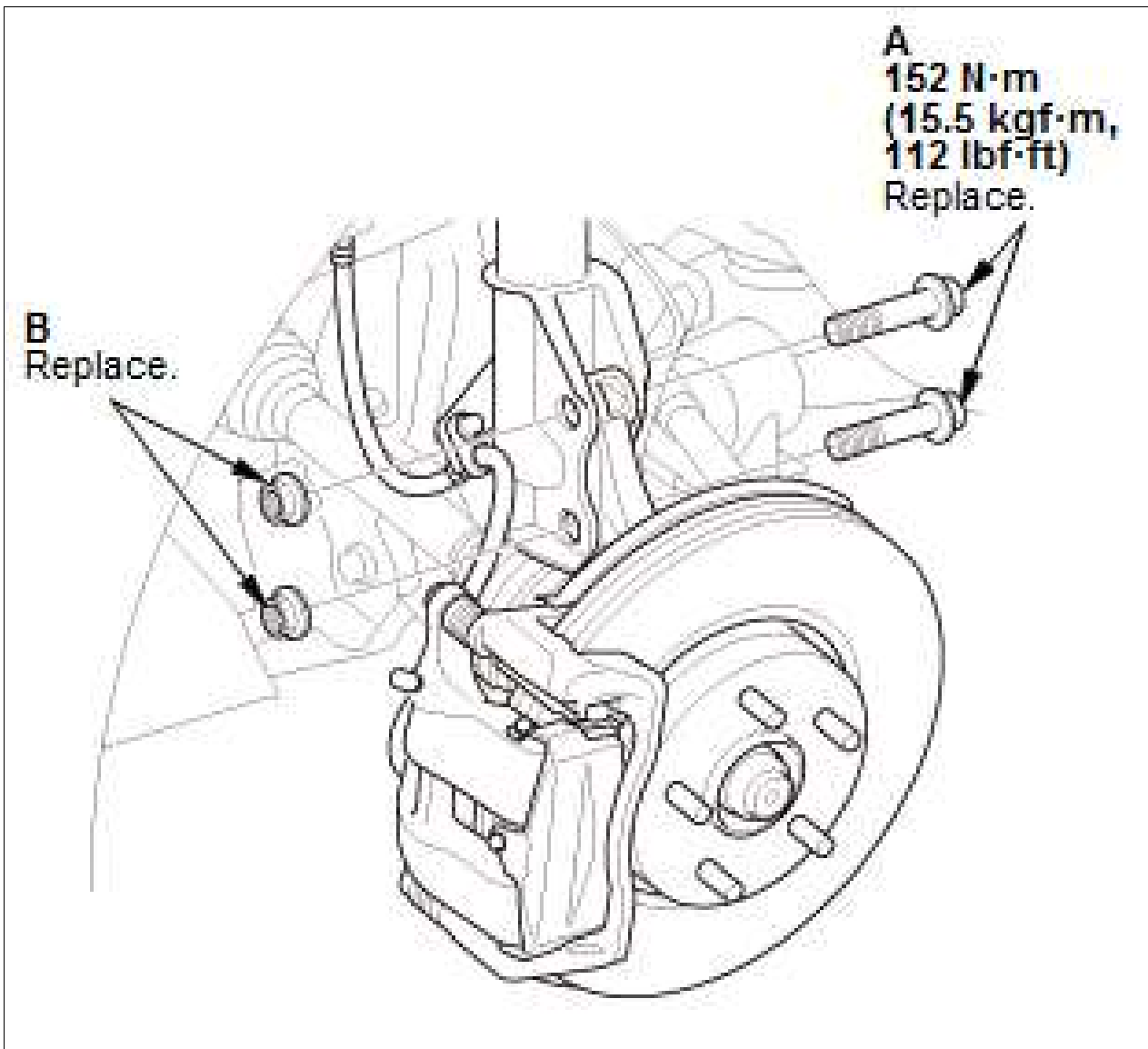

Courtesy of HONDA, U.S.A., INC.

3. Loosely install the new damper pinch bolts (A) and the new flange nuts (B)
 4. Raise the front suspension with a floor jack to load the suspension with the vehicle's weight
 5. Tighten the flange nuts on the upper side of the damper
 6. Tighten the damper pinch bolts while holding the flange nuts on the lower side of the damper.
2. Damper/Spring Items - Install

Fig 3: Stabilizer Link With Torque Specifications

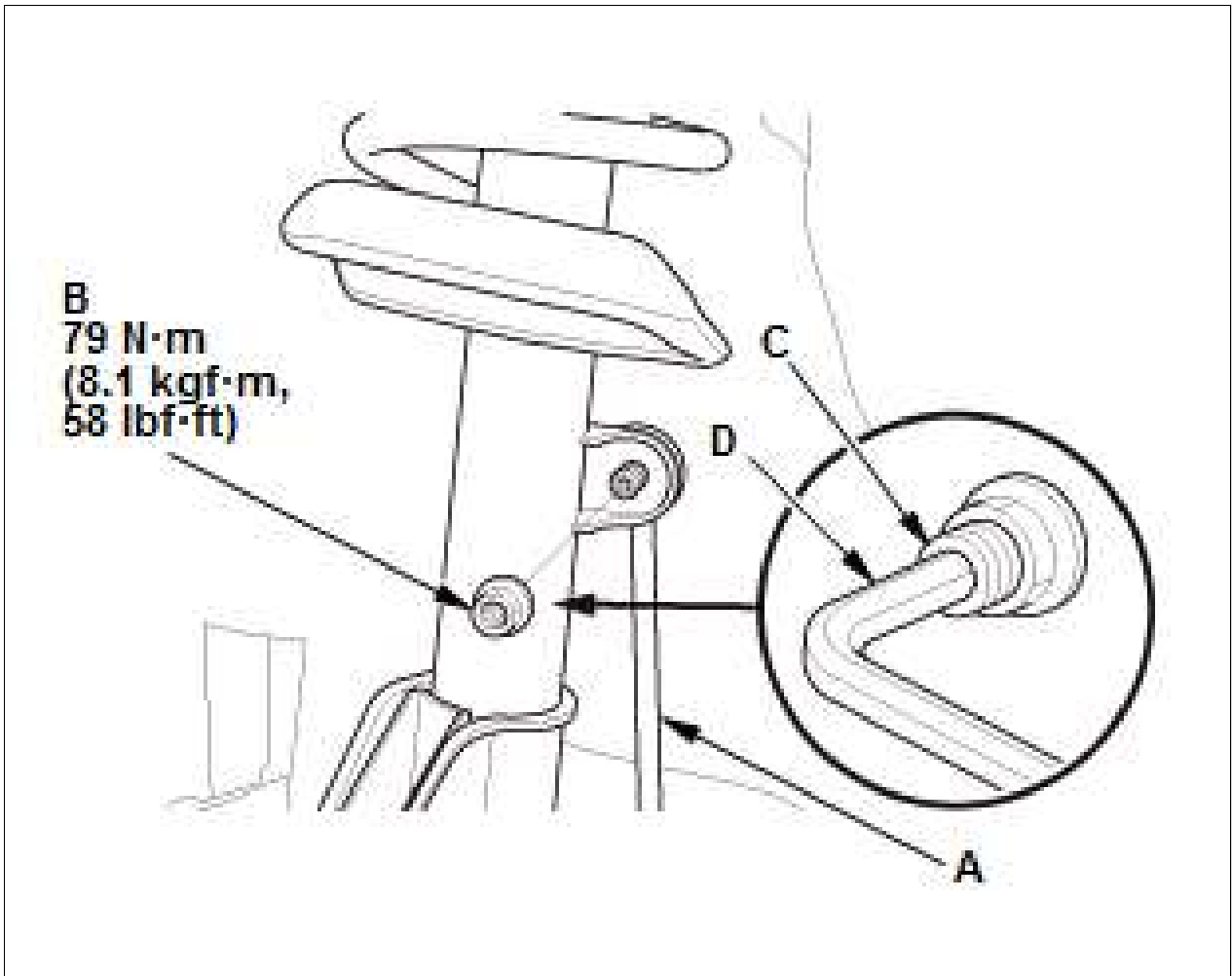

Courtesy of HONDA, U.S.A., INC.

1. Connect the stabilizer link (A) to the damper
2. Tighten the flange nut (B) while holding the joint pin (C) with a hex wrench (D).

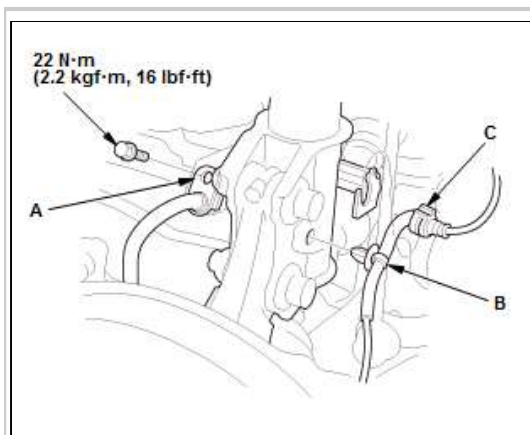

Courtesy of HONDA, U.S.A., INC.

3. Install the brake hose bracket (A)
4. Install the wheel speed sensor harness clip (B) and the wire guide (C).

5. Install the service caps (A).

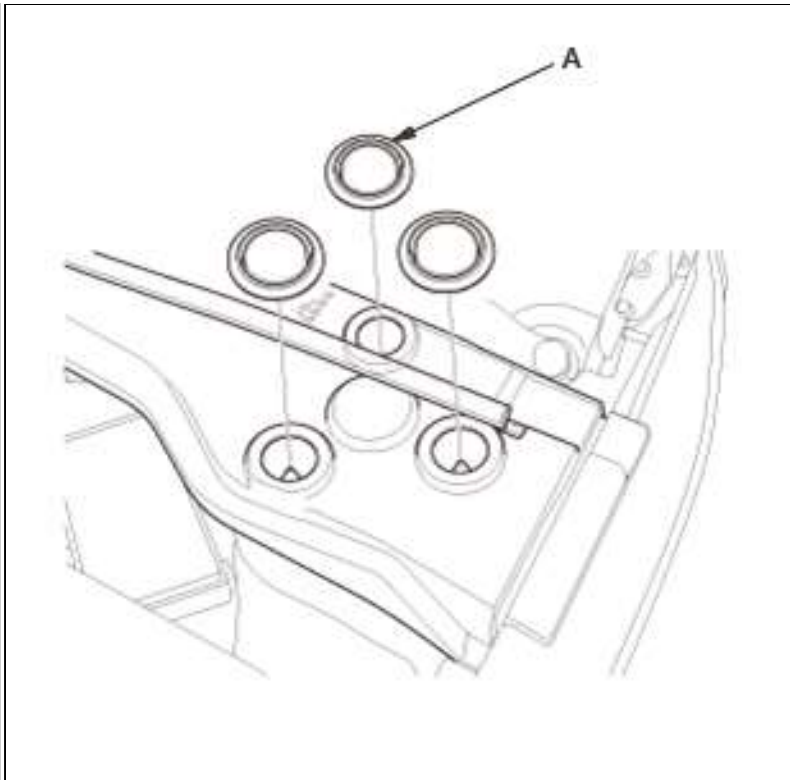

Courtesy of HONDA, U.S.A., INC.

3. Front Wheel - Install

1. Install the front wheel .

4. Wheel Alignment - Check

1. Check the wheel alignment, and adjust it if necessary .

REMOVAL / INSTALLATION > FRONT DAMPER/SPRING REMOVAL AND INSTALLATION (2016-18) > REMOVAL

1. Vehicle - Lift
2. Front Wheel - Remove
3. Damper/Spring Items - Remove

1. Remove the wheel speed sensor harness clip (A) and the wire guide (B).



NOTE: Do not disconnect the wheel speed sensor connector

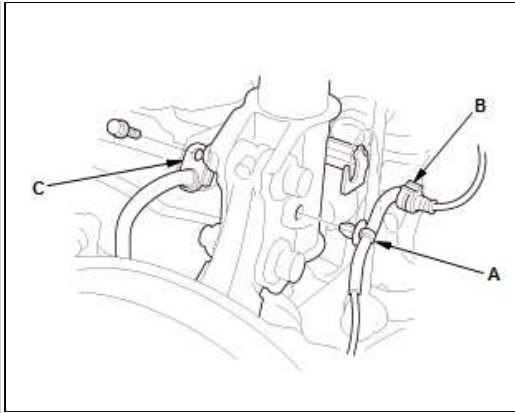

2. Remove the brake hose bracket (C).

Courtesy of HONDA, U.S.A., INC.

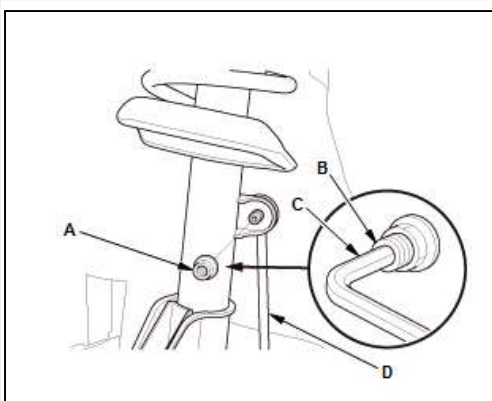

3. Remove the flange nut (A) while holding the joint pin (B) with a hex wrench (C)
 4. Disconnect the stabilizer link (D) from the damper.

Courtesy of HONDA, U.S.A., INC.

4. Damper/Spring - Remove

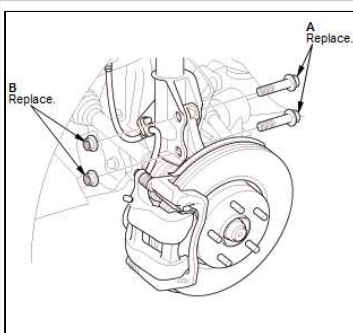

1. Remove the damper pinch bolts (A) and the flange nuts (B).

 **NOTE:** Do not allow the knuckle to rotate too far outward. This may allow the driveshaft inboard joint to come apart.

Courtesy of HONDA, U.S.A., INC.

2. Remove the service caps (A)
 3. Remove the flange nuts (B).

 **NOTE:** Do not let the damper/spring drop down under its

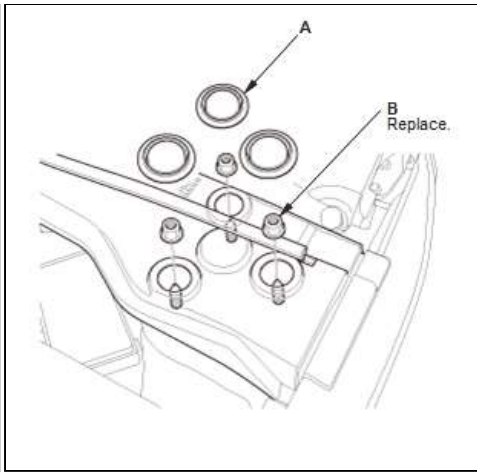

own weight.

Courtesy of HONDA, U.S.A., INC.

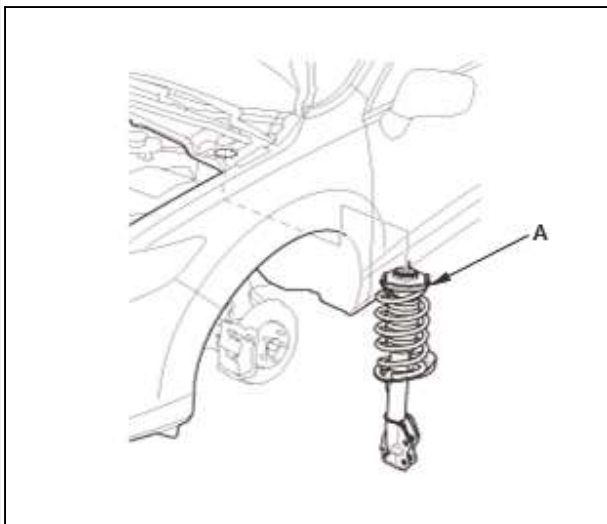

4. Remove the damper/spring (A).

 **NOTE:** Be careful not to damage the body.

Courtesy of HONDA, U.S.A., INC.

REMOVAL / INSTALLATION > FRONT DAMPER/SPRING REMOVAL AND INSTALLATION (2016-18) > INSTALLATION

1. Damper/Spring - Install

1. Install the damper/spring (A). Note the direction of the damper mounting base as shown.

 **NOTE:** Be careful not to damage the body.

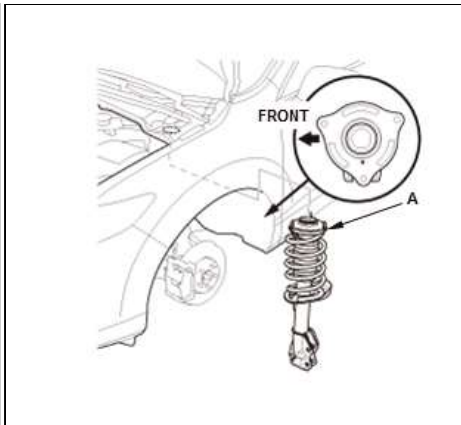

Courtesy of HONDA, U.S.A., INC.

Fig 1: Flange Nuts With Torque Specifications

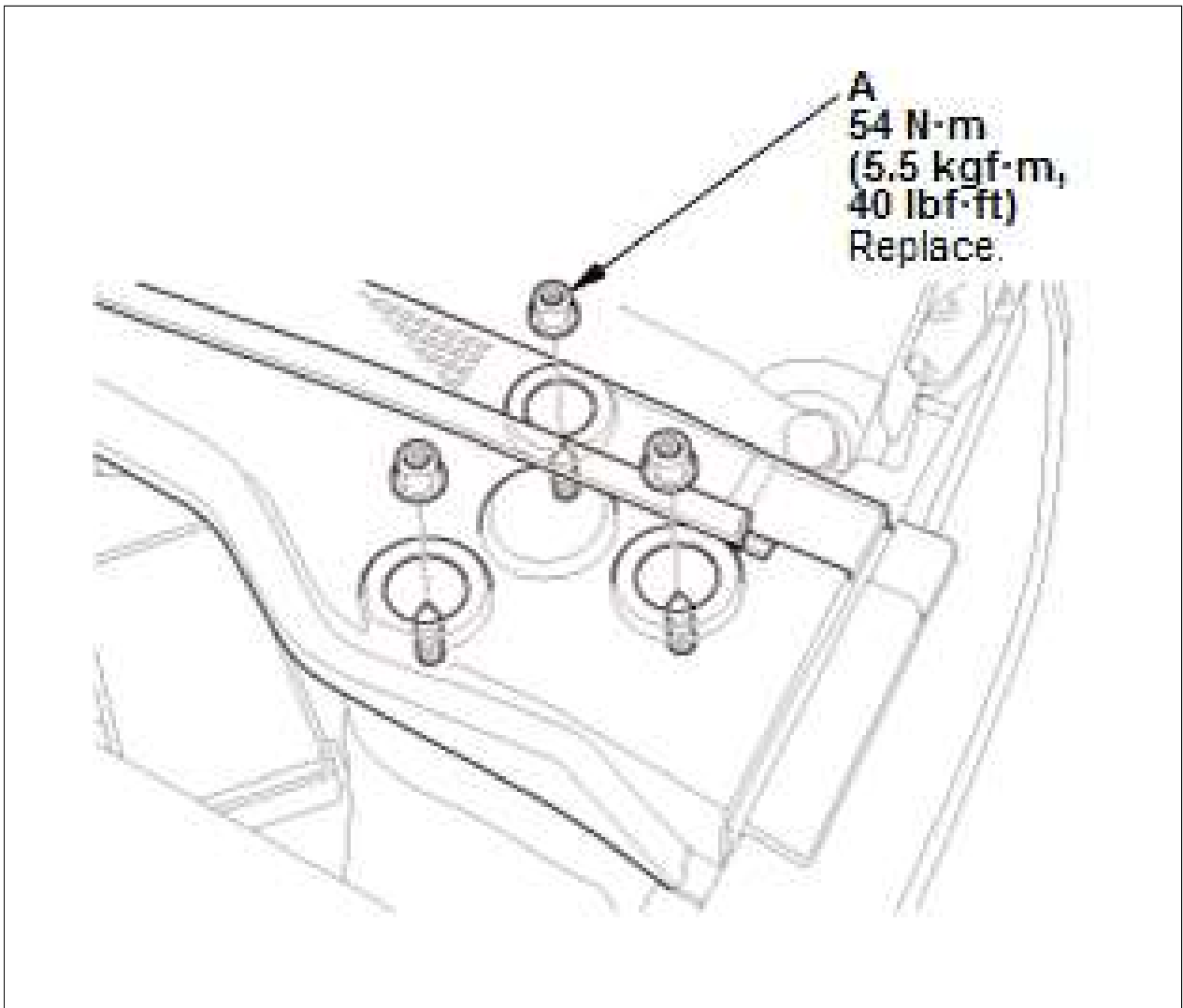

Courtesy of HONDA, U.S.A., INC.

2. Loosely install the new (A).

Fig 2: Damper Pinch Bolts With Torque Specifications

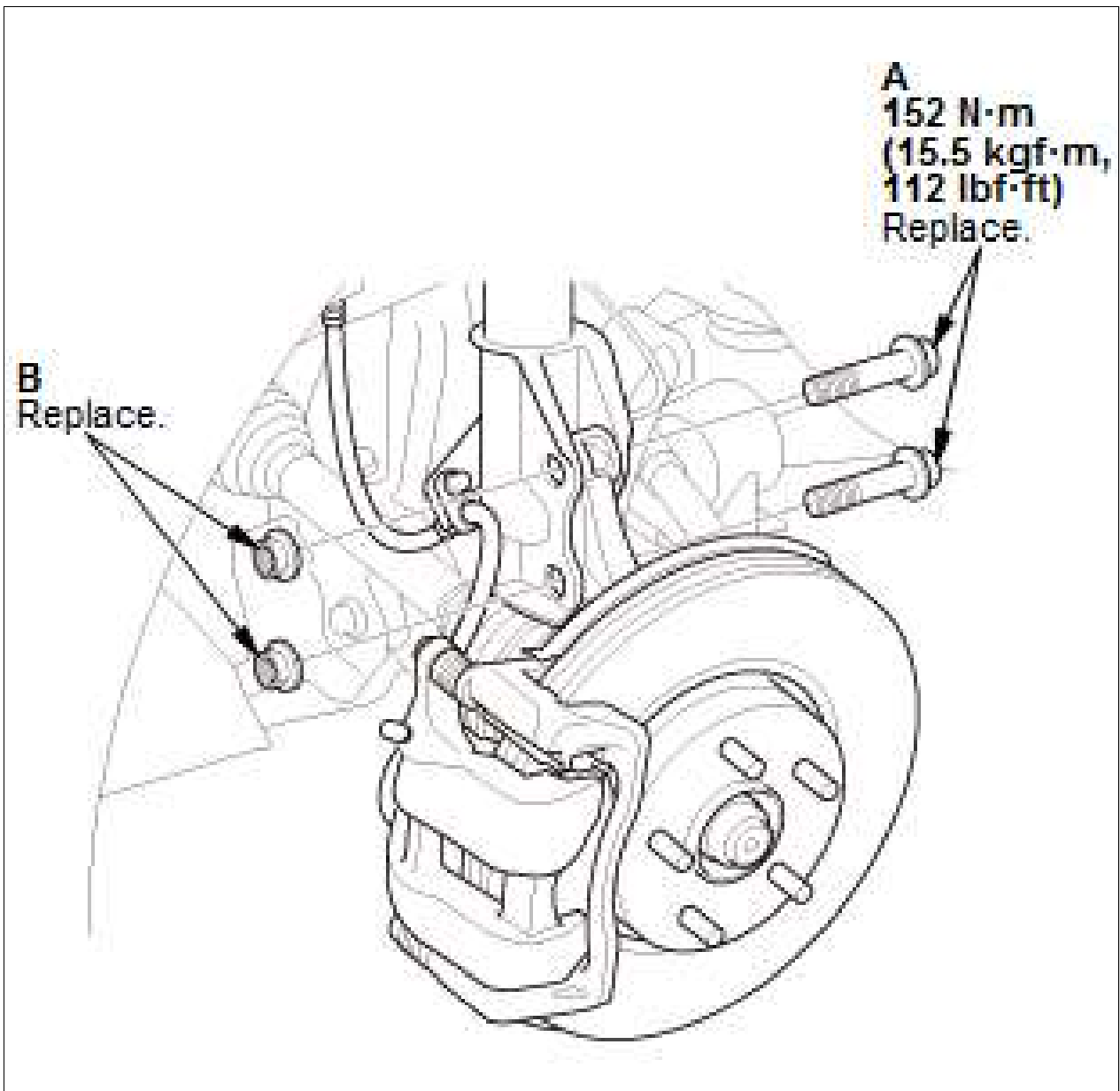

Courtesy of HONDA, U.S.A., INC.

3. Loosely install the new damper pinch bolts (A) and the new flange nuts (B)
 4. Raise the front suspension with a floor jack to load the suspension with the vehicle's weight
 5. Tighten the flange nuts on the upper side of the damper
 6. Tighten the damper pinch bolts while holding the flange nuts on the lower side of the damper.
2. Damper/Spring Items - Install

Fig 3: Stabilizer Link With Torque Specifications

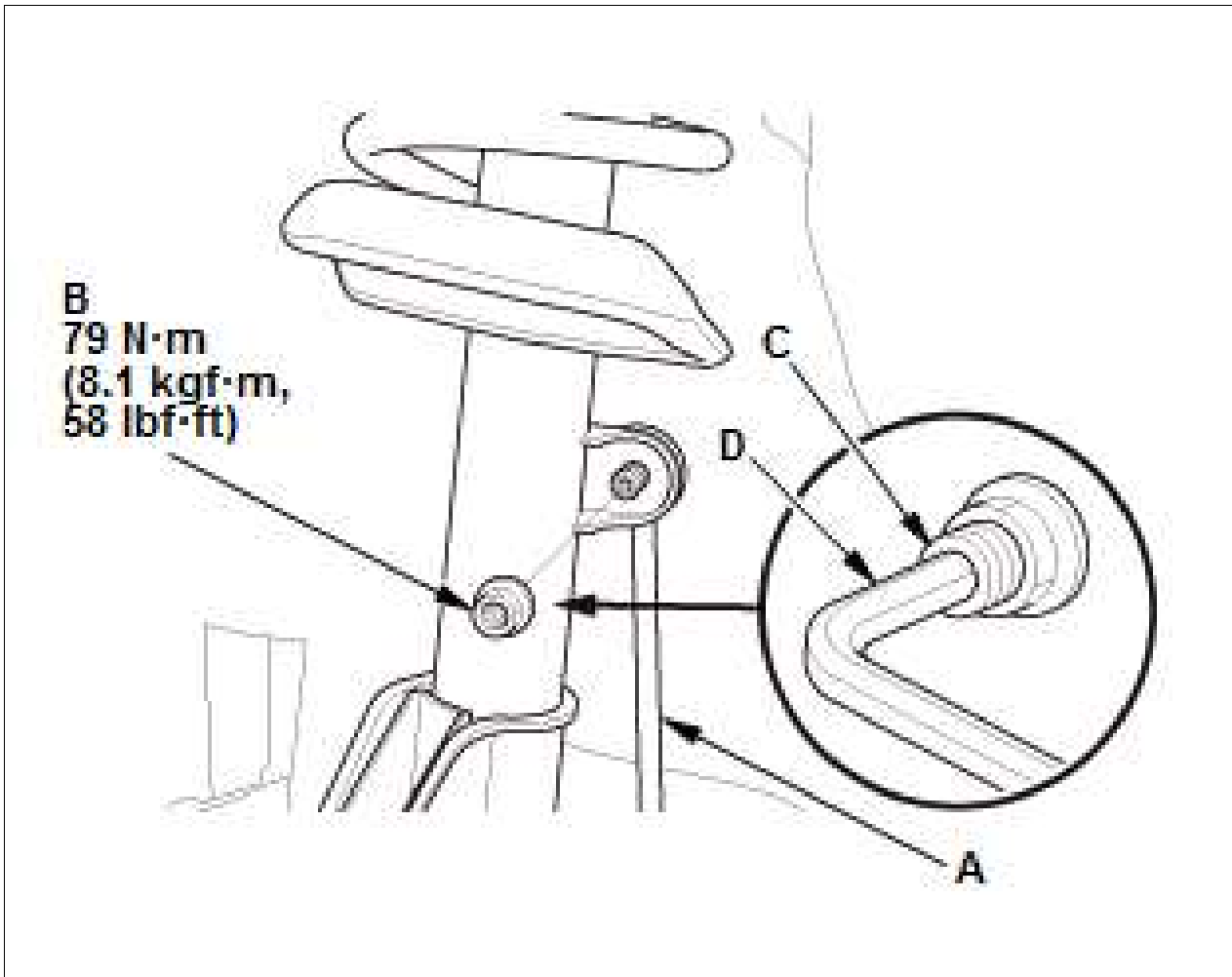

Courtesy of HONDA, U.S.A., INC.

1. Connect the stabilizer link (A) to the damper
2. Tighten the flange nut (B) while holding the joint pin (C) with a hex wrench (D).

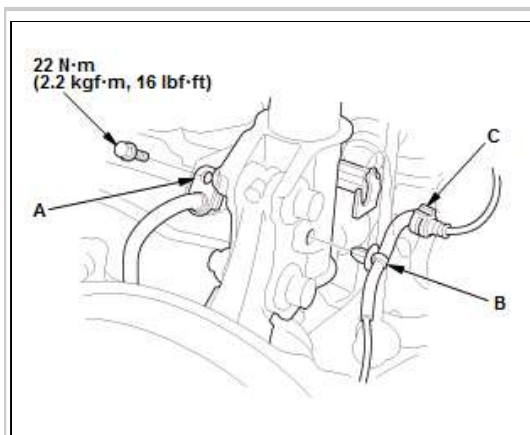

Courtesy of HONDA, U.S.A., INC.

3. Install the brake hose bracket (A)
4. Install the wheel speed sensor harness clip (B) and the wire guide (C).

5. Install the service caps (A).

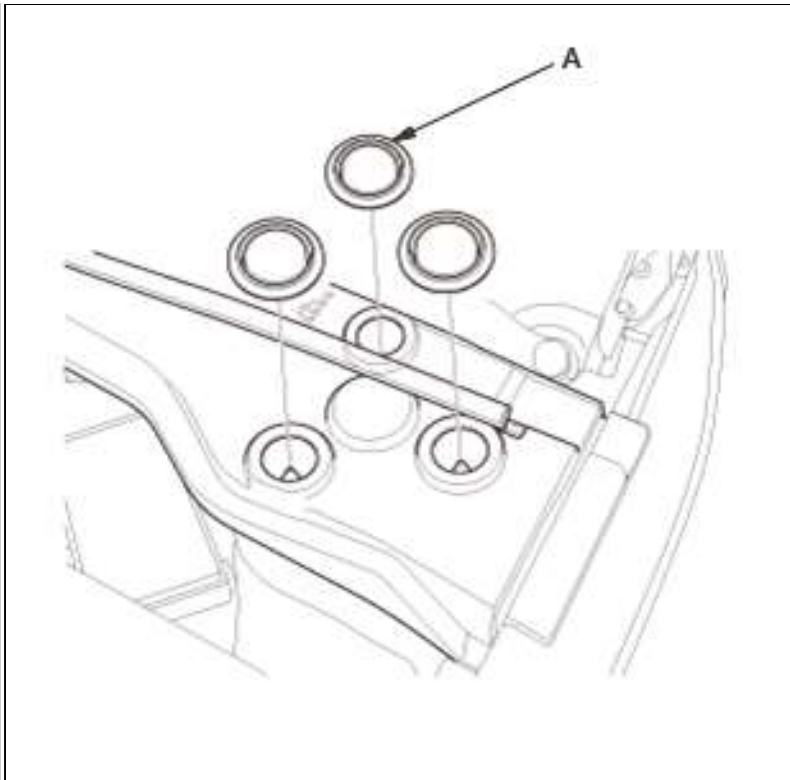

Courtesy of HONDA, U.S.A., INC.

3. Front Wheel - Install
4. Wheel Alignment - Check

REMOVAL / INSTALLATION > FRONT KNUCKLE/HUB/WHEEL BEARING REPLACEMENT (2013-18)

Special Tools Required

Image	Description/Tool Number
	Ball Joint Thread Protector, 12 mm 07AAF-SDAA100

Courtesy of HONDA, U.S.A., INC.



Ball Joint Remover, 28 mm 07MAC-SL00202

Courtesy of HONDA, U.S.A., INC.

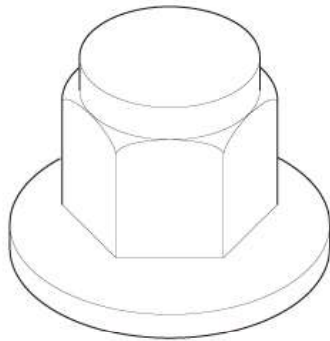

Ball Joint Thread Protector, 14 mm 071AF-SZNA100

Courtesy of HONDA, U.S.A., INC.

Ball Joint Remover, 32 mm 07MAC-SL00102

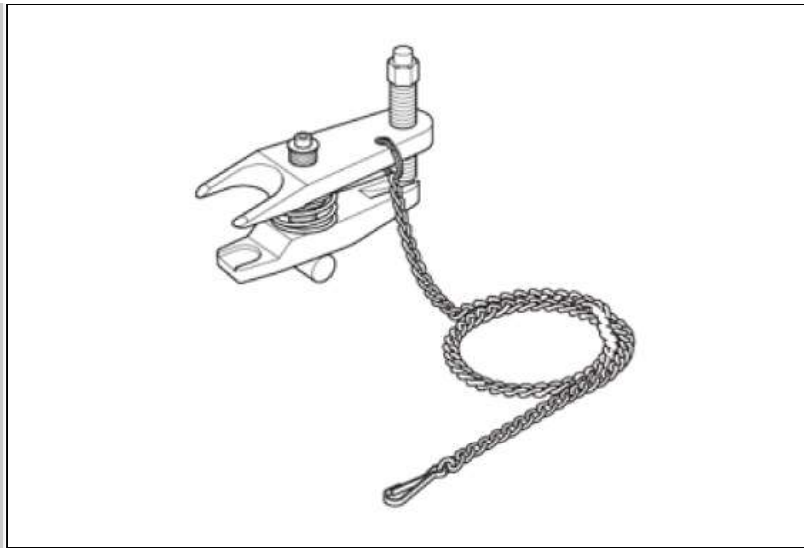

Courtesy of HONDA, U.S.A., INC.

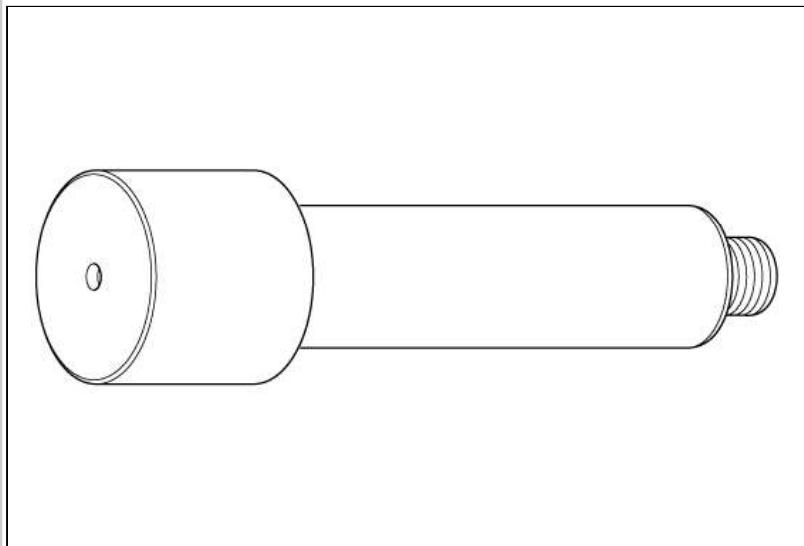

Hub Dis/Assembly Pin, 42 mm
07GAF-SD4A100

Courtesy of HONDA, U.S.A., INC.

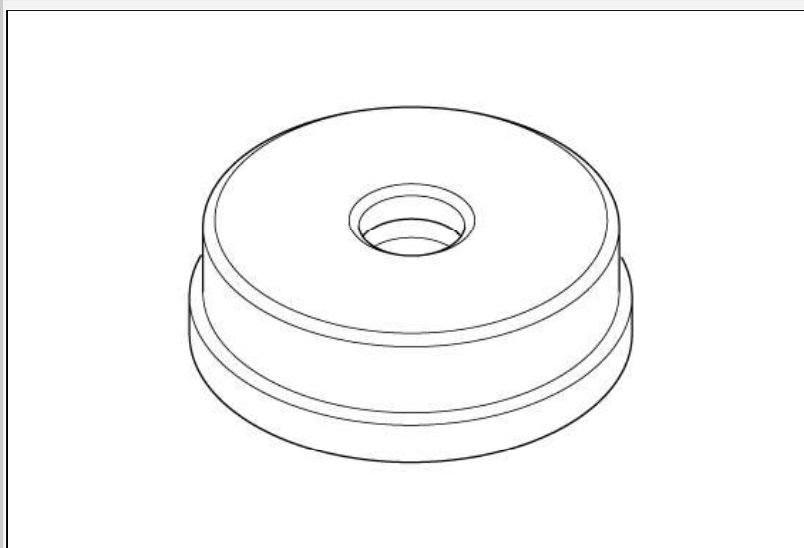

Bearing Driver Attachment, 72 x 75
mm 07746-0010600

Courtesy of HONDA, U.S.A., INC.

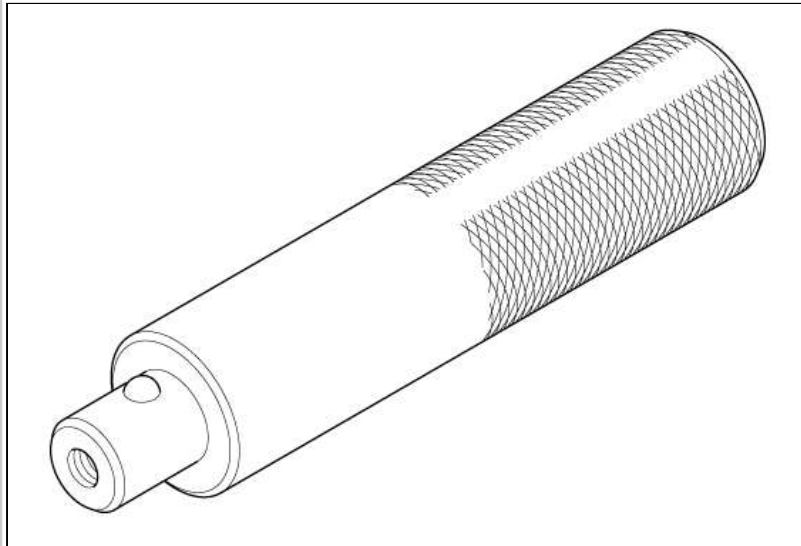

Driver Handle, 15 x 135L 07749-0010000

Courtesy of HONDA, U.S.A., INC.

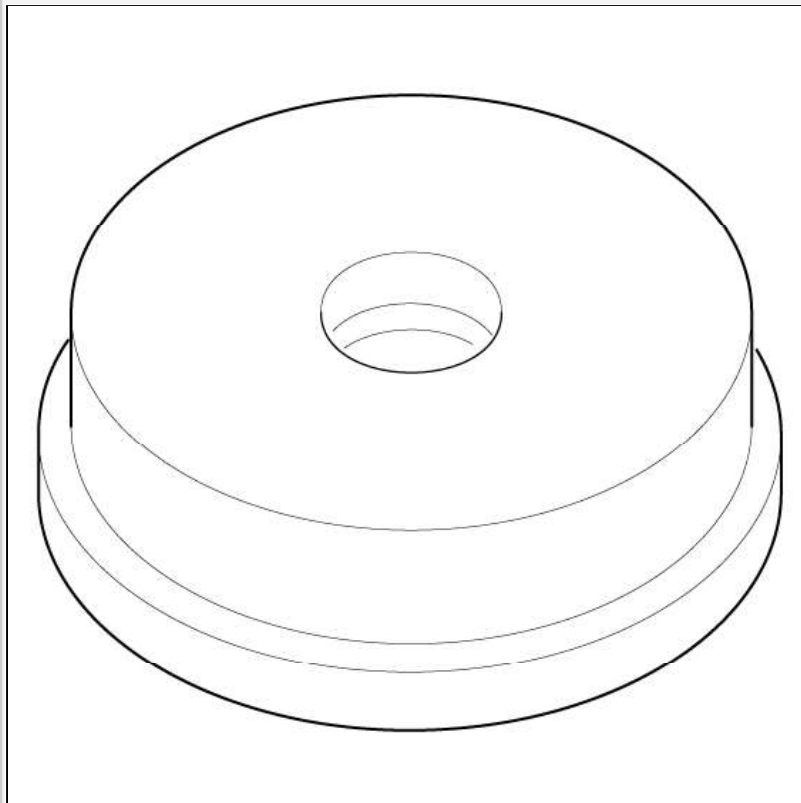

Attachment, 78 x 90 mm 07GAD-SD40101

Courtesy of HONDA, U.S.A., INC.

Support Base 07965-SD90100

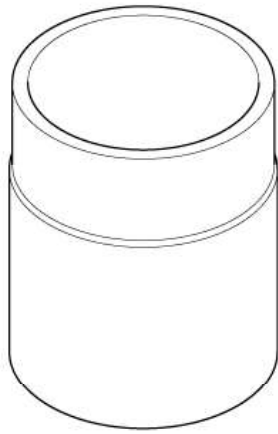

Courtesy of HONDA, U.S.A., INC.

**REMOVAL / INSTALLATION > FRONT KNUCKLE/HUB/WHEEL BEARING
REPLACEMENT (2013-18) > EXPLODED / VIEW**

Fig 1: Exploded View Of Knuckle/Hub/Wheel Bearing With Torque Specifications

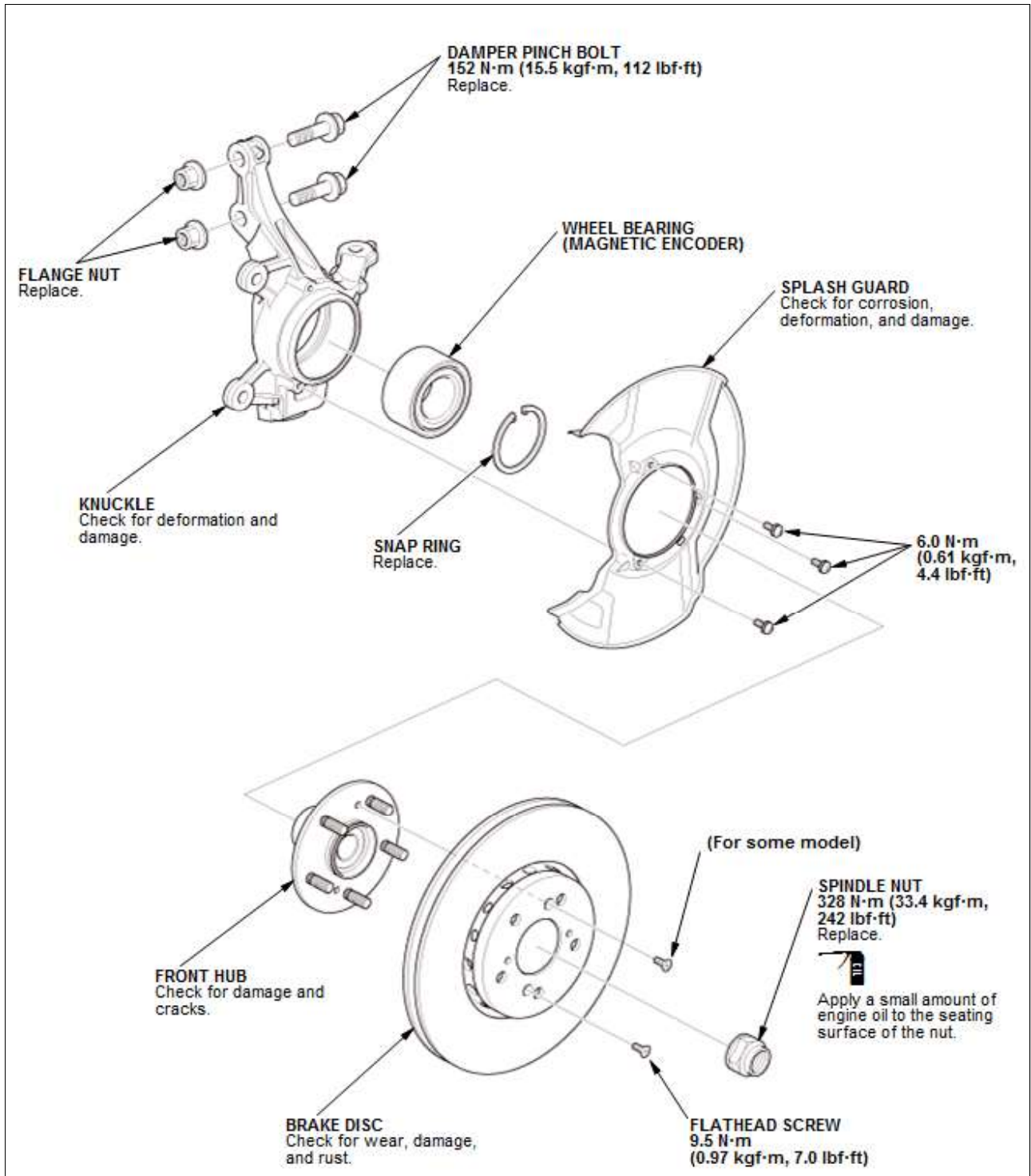

Courtesy of HONDA, U.S.A., INC.

**REMOVAL / INSTALLATION > FRONT KNUCKLE/HUB/WHEEL BEARING
REPLACEMENT (2013-18) > REPLACEMENT**



NOTE: Refer to the Exploded View as needed during the following procedures.

1. Vehicle - Lift

1. Raise and support the vehicle .

2. Front Wheel - Remove

1. Remove the front wheel .

3. Front Brake Caliper - Remove

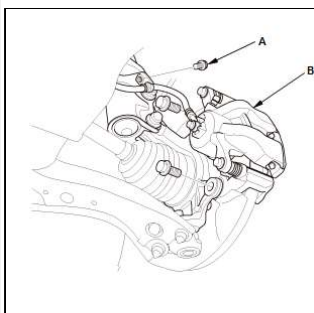

Courtesy of HONDA, U.S.A., INC.

1. Remove the brake hose mounting bolt (A)
2. Remove the caliper assembly (B).



NOTE:

1. To prevent damage to the caliper assembly or brake hose, use a short piece of wire to hang the caliper assembly from the undercarriage.
2. Do not twist the brake hose excessively.

4. Front Wheel Speed Sensor - Remove

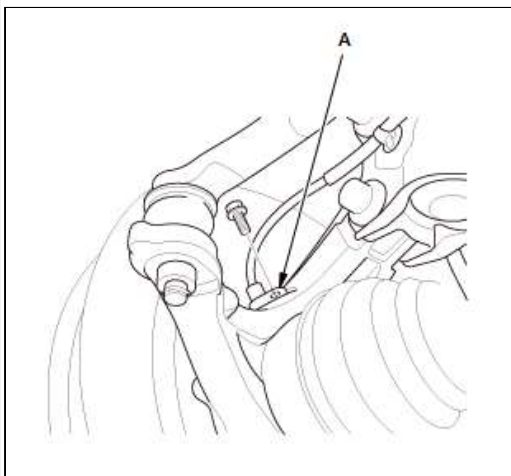

Courtesy of HONDA, U.S.A., INC.

1. Remove the wheel speed sensor (A).



NOTE: Do not disconnect the wheel speed sensor connector.

5. Front Spindle Nut - Remove

1. Pry up the stake (A) on the spindle nut (B)
2. Remove the spindle nut.

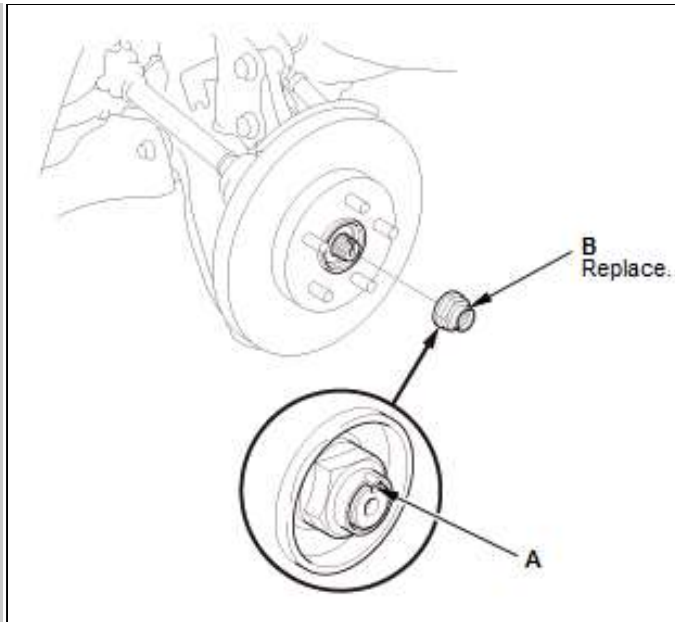

Courtesy of HONDA, U.S.A., INC.

6. Front Brake Disc - Remove

- | |
|----------------------------------|
| 1. Remove the front brake disc . |
|----------------------------------|

7. Hub for Damage and Cracks - Check

- | |
|---|
| 1. Check the front hub for damage and cracks. |
|---|

8. Tie-Rod End Ball Joint - Disconnect

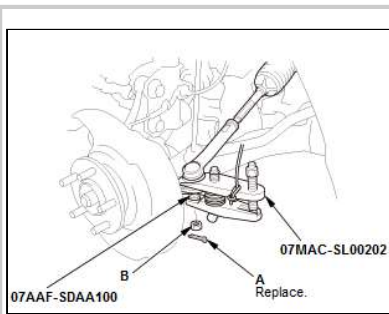

Courtesy of HONDA, U.S.A., INC.

1. Remove the cotter pin (A).
2. Remove the nut (B).
3. Disconnect the tie-rod end ball joint from the knuckle using the ball joint thread protector and the ball joint remover .

NOTE: Be careful not to damage the ball joint boot when installing the ball joint remover.

9. Lower Arm Ball Joint - Disconnect

- | |
|--|
| <ol style="list-style-type: none"> 1. Remove the lock pin (A). 2. Remove the castle nut (B). 3. Disconnect the lower arm ball joint from the knuckle using the ball joint thread protector and the ball joint remover . |
|--|

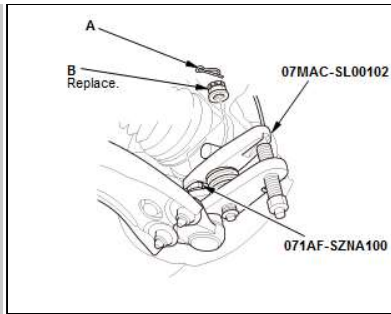

NOTE: Be careful not to damage the ball joint boot when installing the ball joint remover.

Courtesy of HONDA, U.S.A., INC.

10. Knuckle/Hub Assembly - Remove

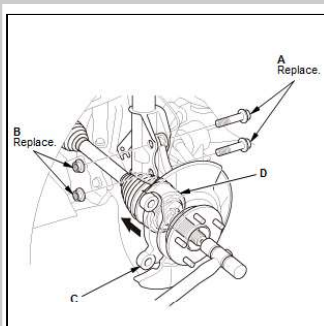

1. Remove the damper pinch bolts (A) and the flange nuts (B)
2. Pull the knuckle (C) outward, and separate the outboard joint (D) from the front hub using a soft face hammer outward, then remove the knuckle/hub.

NOTE: Do not pull the driveshaft end outward. The inner driveshaft inboard joint may come apart.

Courtesy of HONDA, U.S.A., INC.

11. Hub - Remove

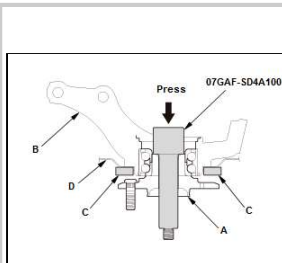

Courtesy of HONDA, U.S.A., INC.

1. Separate the hub (A) from the knuckle (B) using the hub dis/assembly pin and a hydraulic press. Hold the knuckle with the attachment (C) of the hydraulic press or equivalent tool.

NOTE:

1. Be careful not to damage or deform the splash guard (D).
2. Hold onto the hub to keep it from falling when pressed clear.

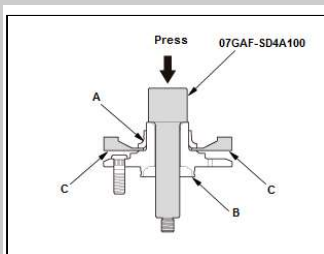

Courtesy of HONDA, U.S.A., INC.

2. Press out the wheel bearing inner race (A) of the hub (B) using the hub dis/assembly pin, a commercially available bearing separator (C), and a press.

12. Splash Guard and Snap Ring - Remove

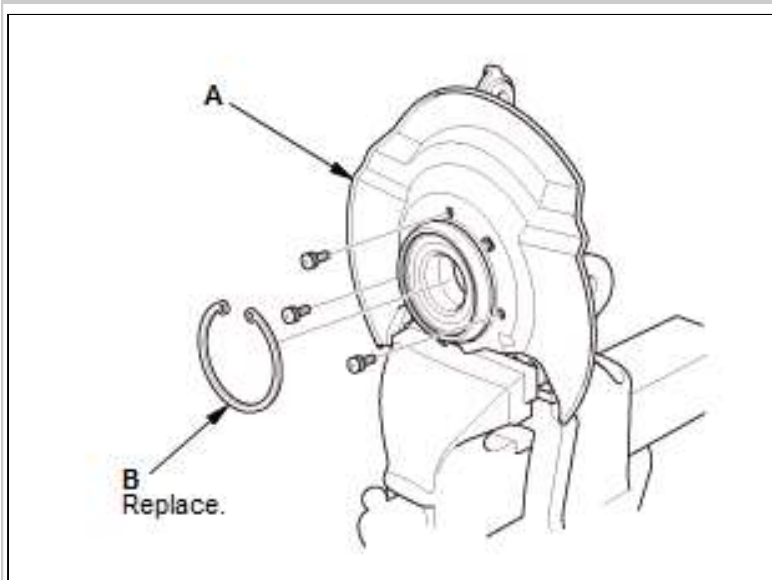

1. Remove the splash guard (A)
2. Remove the snap ring (B).

Courtesy of HONDA, U.S.A., INC.

13. Bearing - Remove

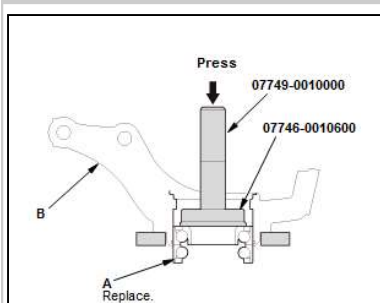

1. Press the wheel bearing (A) out of the knuckle (B) using the bearing driver attachment, the driver handle, and a press.

Courtesy of HONDA, U.S.A., INC.

14. Bearing - Install

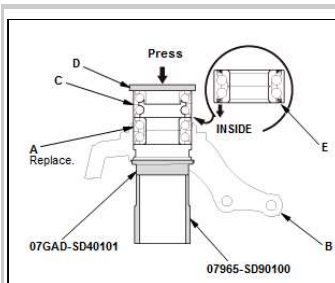

1. Wash the knuckle and the hub thoroughly in high flash point solvent before reassembly
2. Press a new wheel bearing (A) into the knuckle (B) using the old bearing (C), a steel plate (D), the attachment, the support base, and a press.

NOTE:

1. Install the wheel bearing with the wheel speed sensor magnetic encoder (E) (brown color) toward the inside of the knuckle.

Courtesy of HONDA, U.S.A., INC.

2. Remove any oil, grease, dust, metal debris, and other foreign material from the encoder surface.
3. Keep any magnetic tools away from the encoder surface.
4. Keep the wheel bearing and magnetic encoder away from any magnetic field. The encoder can be damaged or erased.
5. Be careful not to damage the encoder surface when you insert the wheel bearing.

15. Splash Guard and Snap Ring - Install

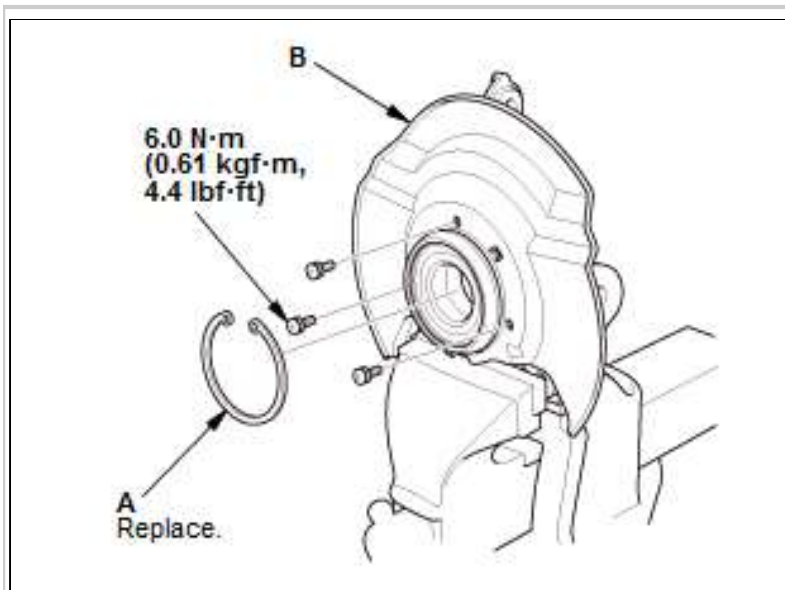

1. Install the new snap ring (A)
2. Install the splash guard (B).

Courtesy of HONDA, U.S.A., INC.

16. Hub - Install

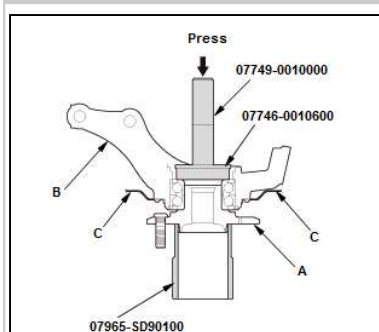

1. Install the hub (A) onto the knuckle (B) using the attachment, the driver handle, the support base, and a hydraulic press.

 **NOTE:** Be careful not to damage the splash guard (C).

Courtesy of HONDA, U.S.A., INC.

17. Knuckle/Hub Assembly - Install

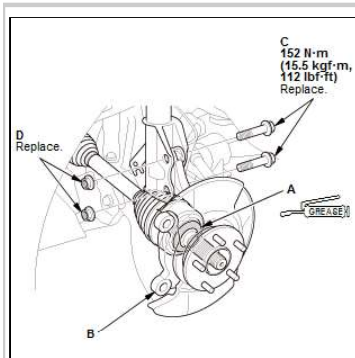

Courtesy of HONDA, U.S.A., INC.

1. Apply about 5 g (0.18 oz) of moly 60 paste (P/N 08734-0001) to the contact area (A) of the outboard joint and the front wheel bearing
2. Install the knuckle/hub (B)
3. Install the new damper pinch bolts (C) and the new flange nuts (D).

18. Lower Arm Ball Joint - Connect

Fig 1: Lower Arm Ball Joint With Torque Specifications

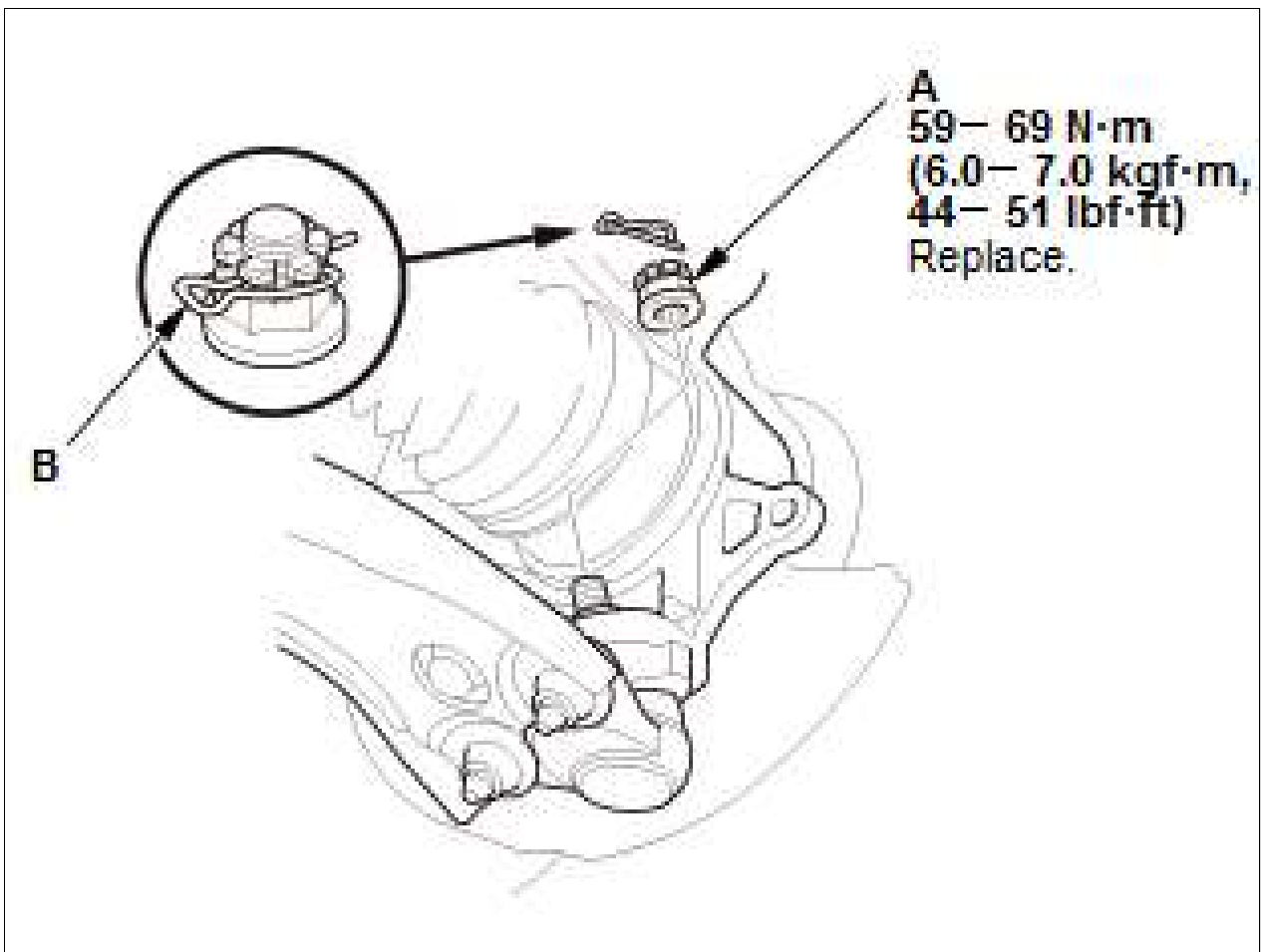

Courtesy of HONDA, U.S.A., INC.

1. Connect the lower arm ball joint to the knuckle
2. Install the new castle nut (A).

 **NOTE:** Torque the castle nut to the lower torque specification, then tighten it only far enough to align the slot with the ball joint pin hole. Do not align the castle nut by loosening it

3. Install the lock pin (B) as shown.

19. Tie-Rod End Ball Joint - Connect

Fig 2: Tie-Rod End Ball Joint With Torque Specifications

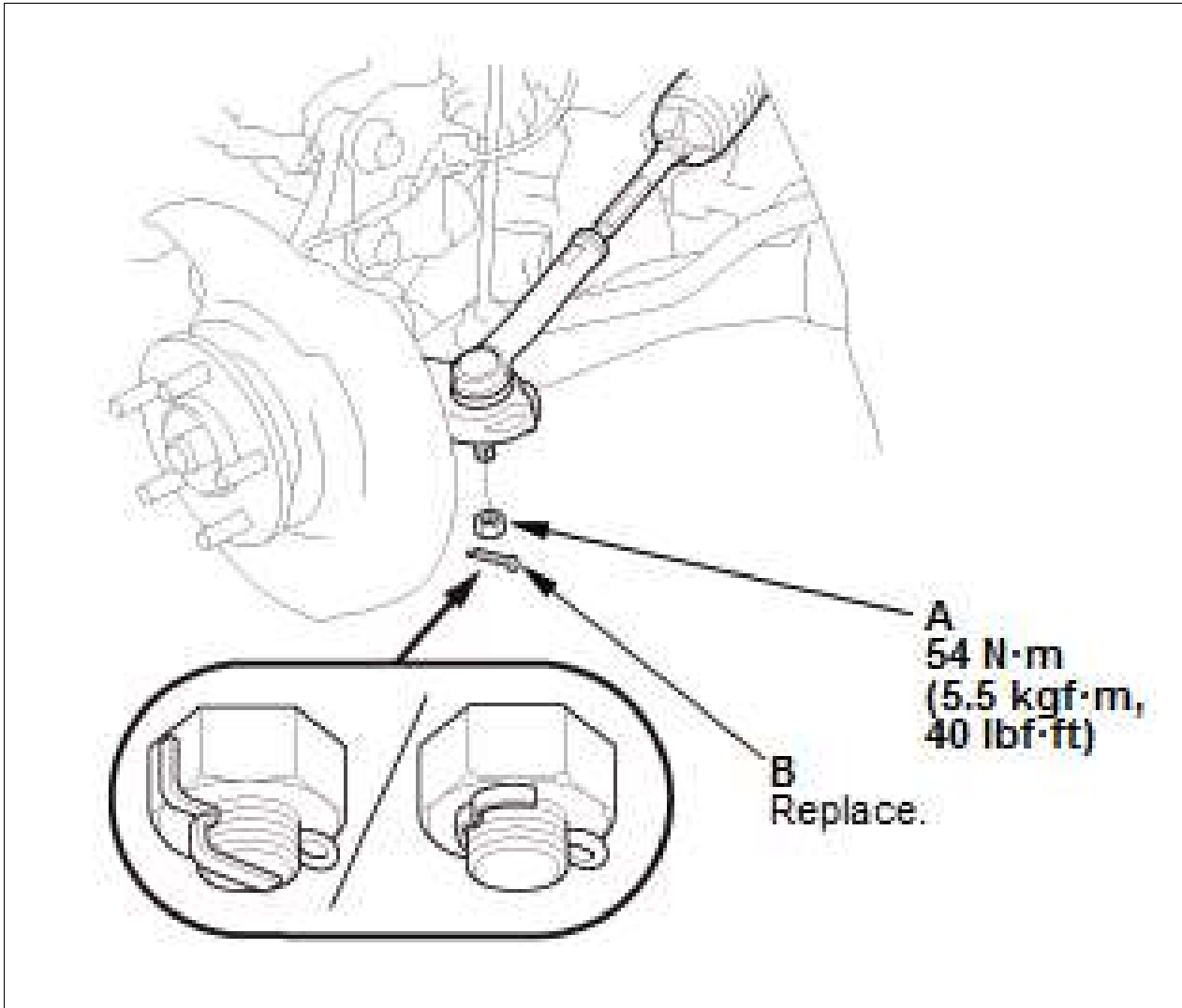

Courtesy of HONDA, U.S.A., INC.

1. Connect the tie-rod end ball joint to the knuckle
2. Install the nut (A)
3. Install the new cotter pin (B) as shown.

20. Front Brake Disc- Install

- | |
|-----------------------------------|
| 1. Install the front brake disc . |
|-----------------------------------|

21. Front Spindle Nut - Install

Fig 3: Front Spindle Nut With Torque Specifications

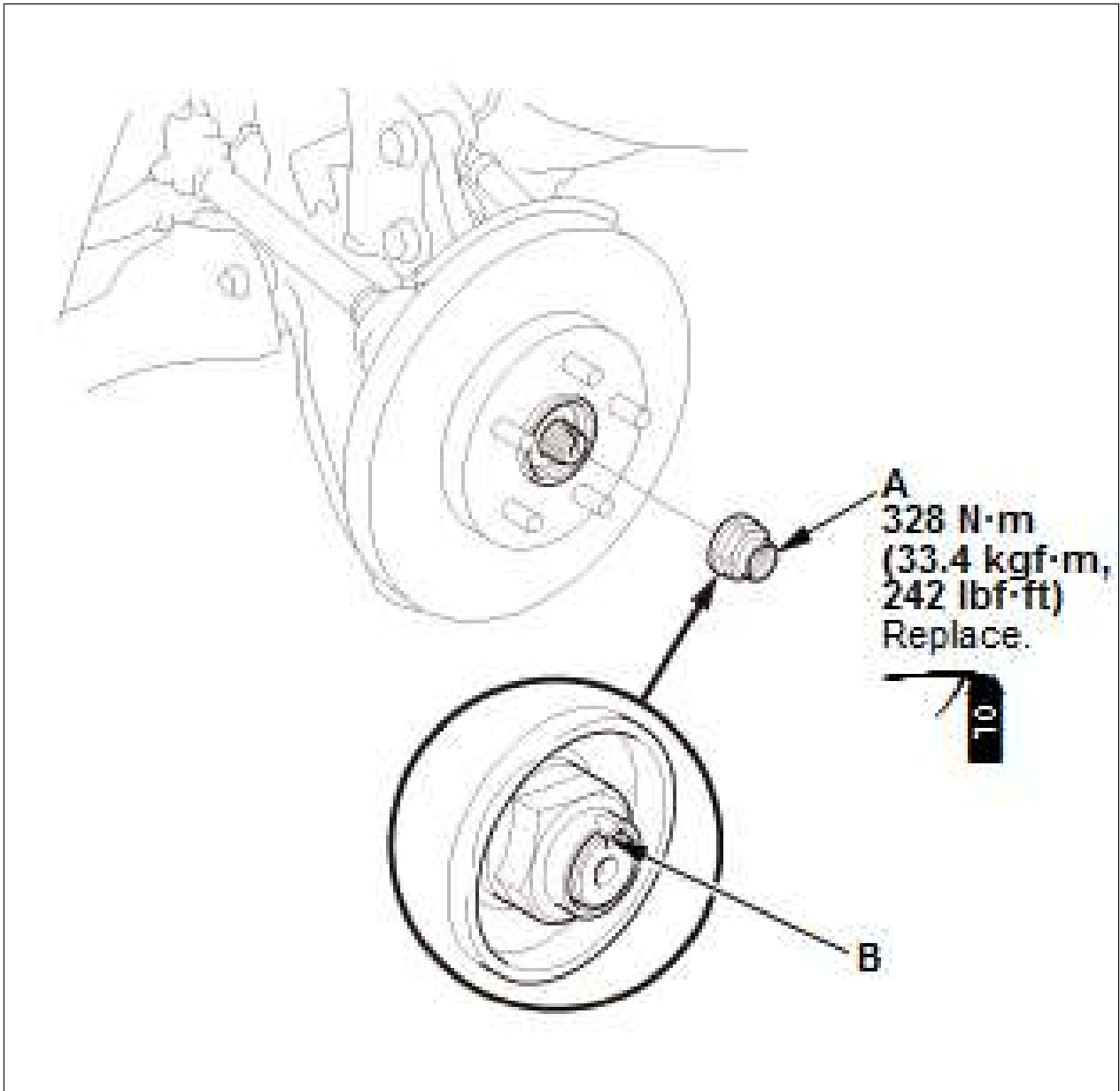

Courtesy of HONDA, U.S.A., INC.

1. Apply a small amount of engine oil to the seating surface of a new spindle nut (A)
2. Install the spindle nut
3. Use a drift to stake the spindle nut shoulder (B) against the driveshaft.

22. Front Wheel Speed Sensor - Install

	1. Install the wheel speed sensor (A).
--	--

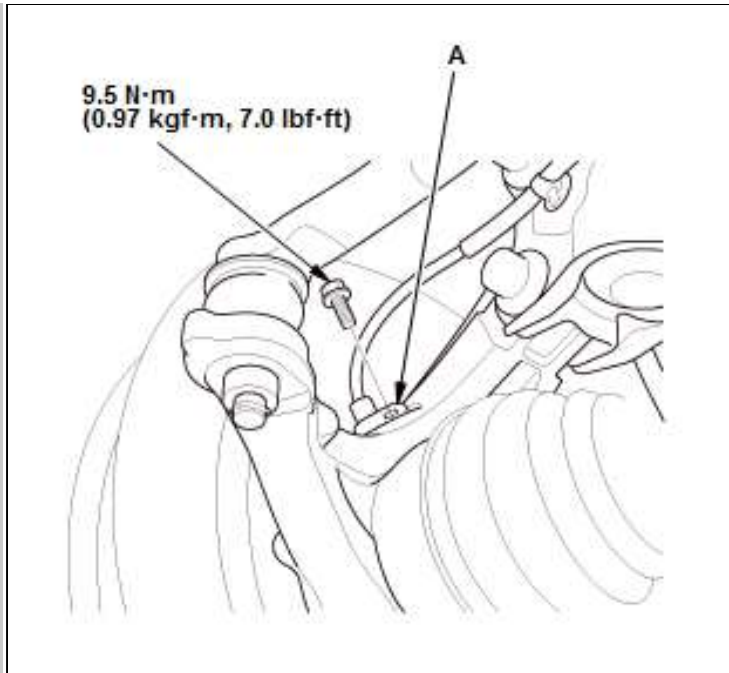

Courtesy of HONDA, U.S.A., INC.

23. Front Brake Caliper - Install

Fig 4: Front Brake Caliper With Torque Specifications

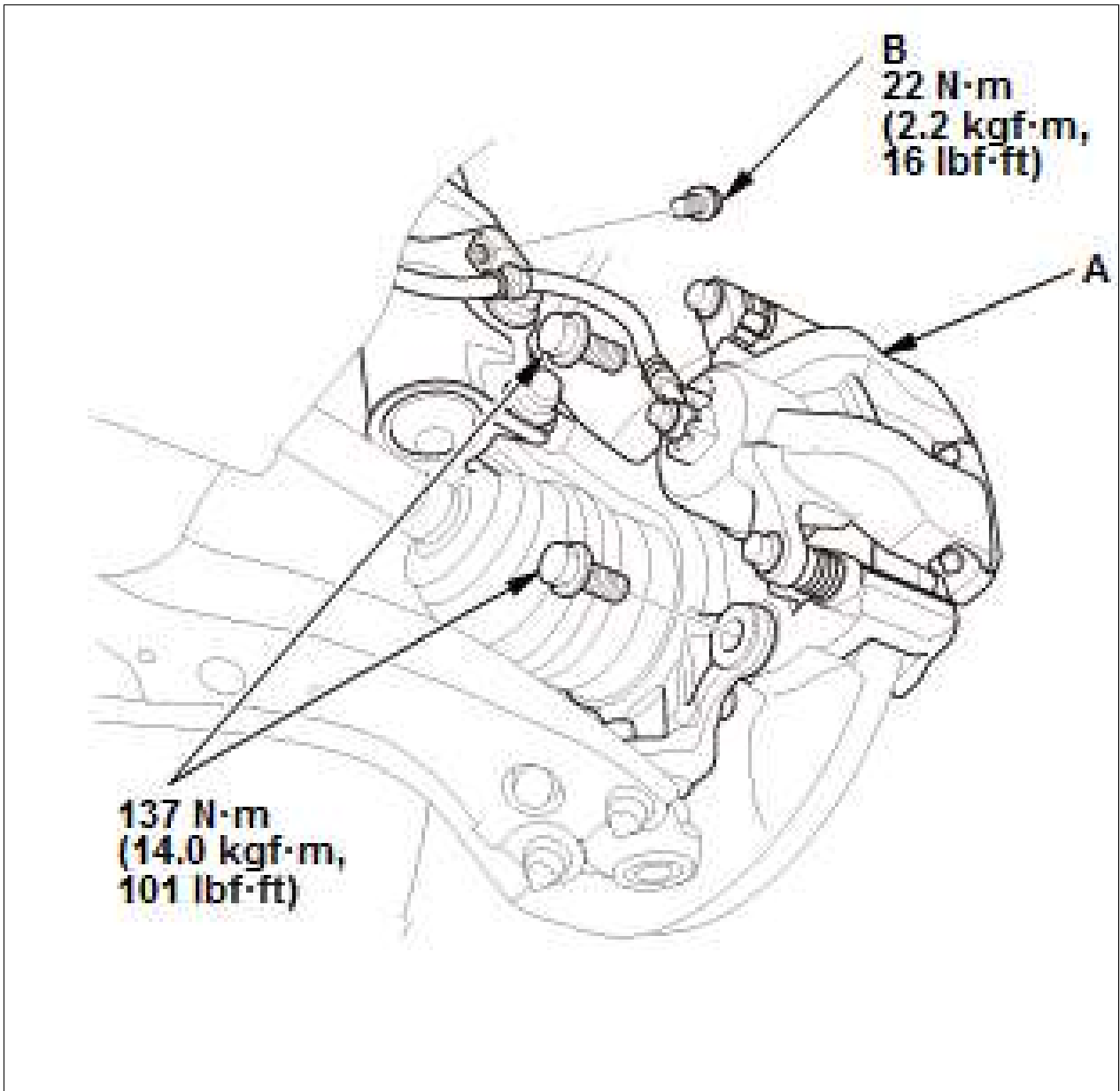

Courtesy of HONDA, U.S.A., INC.

1. Install the caliper assembly (A)
2. Install the brake hose mounting bolt (B).

24. Front Wheel - Install



1. Install the front wheel .

25. Wheel Alignment - Check

1. Check the wheel alignment, and adjust it if necessary .
--

REMOVAL / INSTALLATION > FRONT LOWER ARM BALL JOINT REMOVAL AND INSTALLATION (2013-18)

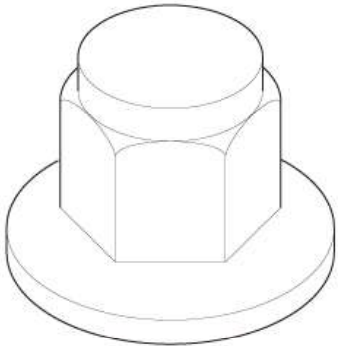
Special Tools Required

Image	Description/Tool Number
 <p>Courtesy of HONDA, U.S.A., INC.</p>	<p>Ball Joint Thread Protector, 14 mm 071AF-SZNA100</p>
 <p>Courtesy of HONDA, U.S.A., INC.</p>	<p>Ball Joint Remover, 32 mm 07MAC-SL00102</p>

REMOVAL / INSTALLATION > FRONT LOWER ARM BALL JOINT REMOVAL AND INSTALLATION (2013-18) > REMOVAL

1. Vehicle - Lift

1. Raise and support the vehicle .

2. Front Wheel - Remove

1. Remove the front wheel .

3. Lower Arm Ball Joint - Disconnect

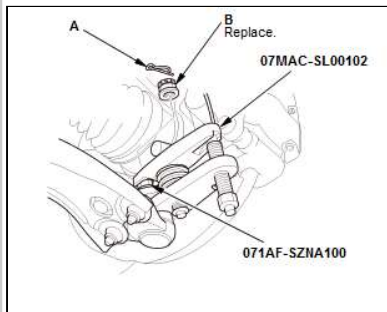

Courtesy of HONDA, U.S.A., INC.

1. Remove the lock pin (A).
2. Remove the castle nut (B).
3. Disconnect the lower arm ball joint from the knuckle using the ball joint thread protector and the ball joint remover .

 **NOTE:** Be careful not to damage the ball joint boot when installing the ball joint remover.

4. Lower Arm Ball Joint - Remove

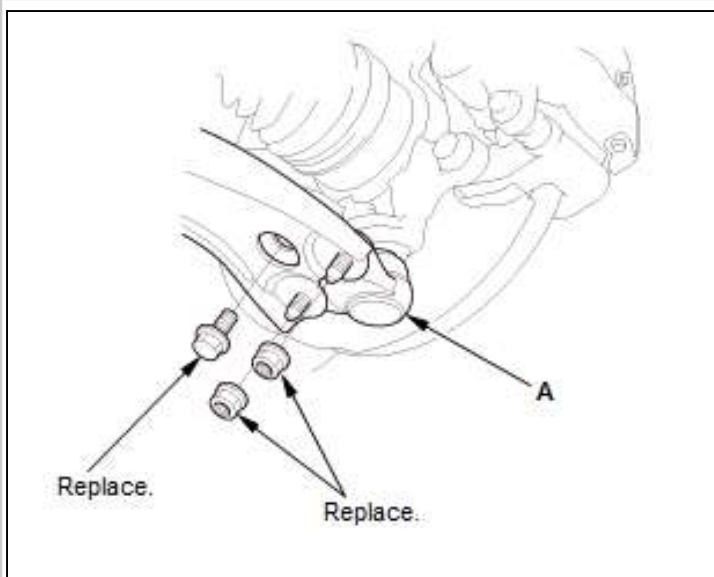

Courtesy of HONDA, U.S.A., INC.

1. Remove the lower arm ball joint (A).

REMOVAL / INSTALLATION > FRONT LOWER ARM BALL JOINT REMOVAL AND INSTALLATION (2013-18) > INSTALLATION

1. Lower Arm Ball Joint - Install

Fig 1: Lower Arm Ball Joint With Torque Specifications

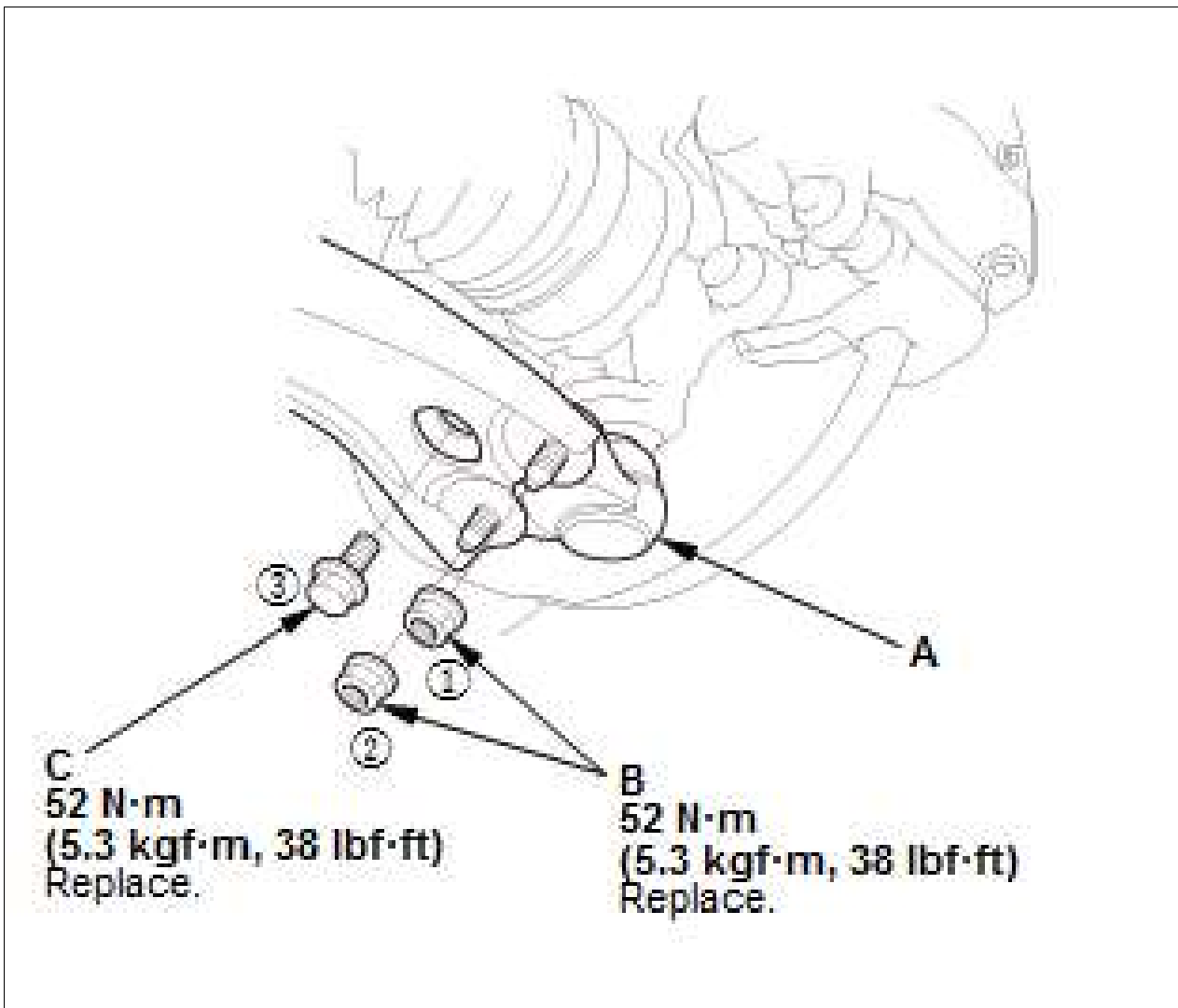

Courtesy of HONDA, U.S.A., INC.

1. Install the lower arm ball joint (A) to the lower arm
 2. Loosely install the new self-locking nuts (B) and the new flange bolt (C)
 3. Tighten the self-locking nuts and the flange bolt in the sequence shown.
2. Lower Arm Ball Joint - Connect

Fig 2: Lower Arm Ball Joint With Torque Specifications

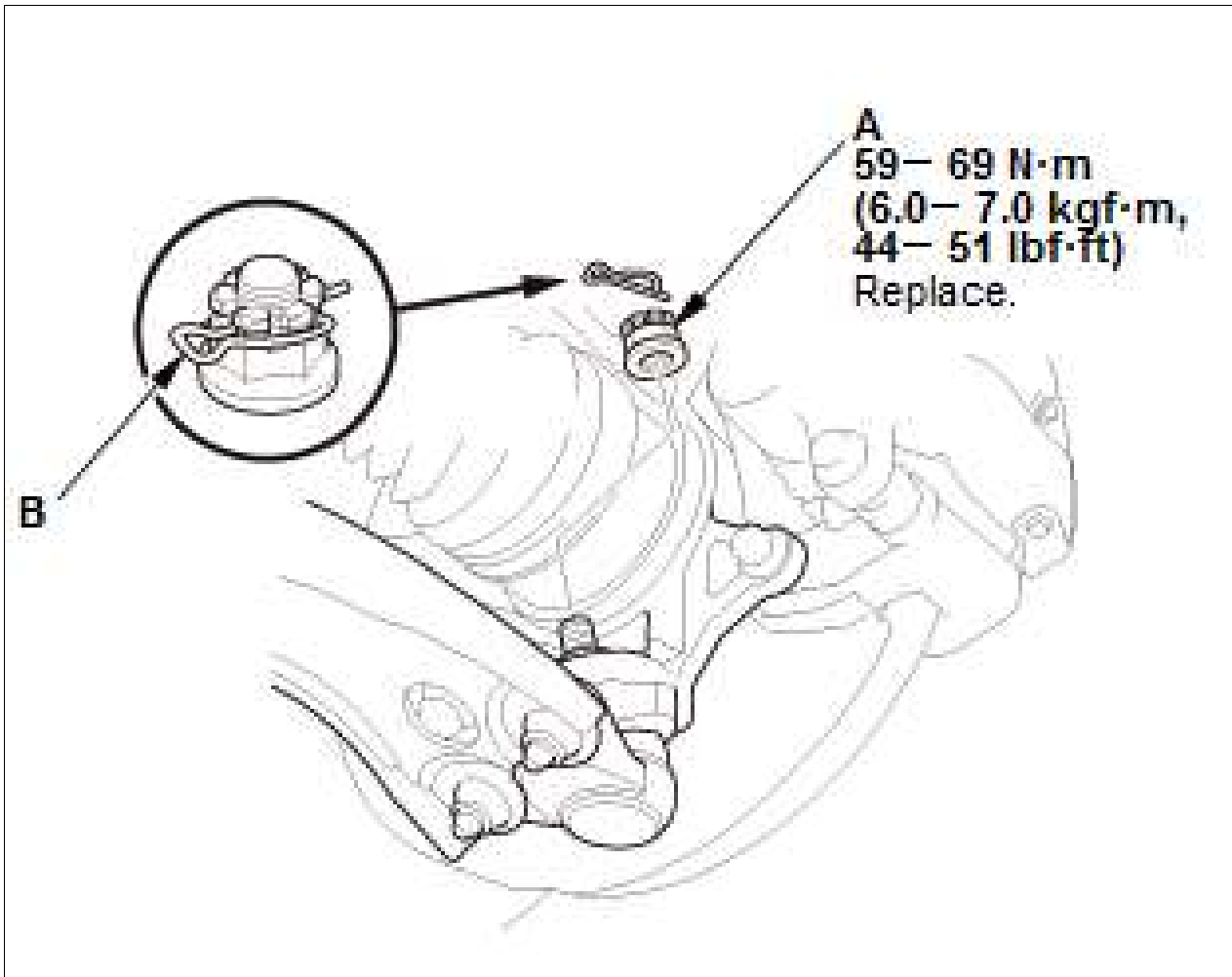

Courtesy of HONDA, U.S.A., INC.

1. Connect the lower arm ball joint to the knuckle
2. Install the new castle nut (A).

 **NOTE:** Torque the castle nut to the lower torque specification, then tighten it only far enough to align the slot with the ball joint pin hole. Do not align the castle nut by loosening it

3. Install the lock pin (B) as shown.
3. Front Wheel - Install

1. Install the front wheel .

4. Wheel Alignment - Check

1. Check the wheel alignment, and adjust it if necessary .
--

REMOVAL / INSTALLATION > FRONT LOWER ARM COMPLIANCE BUSH REMOVAL AND INSTALLATION (2013-18) > REMOVAL

1. Vehicle - Lift

1. Raise and support the vehicle .

2. Front Wheel - Remove

1. Remove the front wheel .

3. Lower Arm - Remove

1. Remove the lower arm .

4. Lower Arm Bushing - Remove

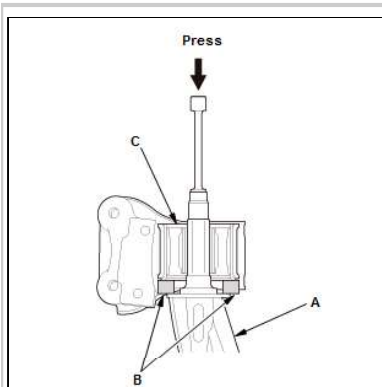

Courtesy of HONDA, U.S.A., INC.

1. Support the lower arm (A) on suitable bar (B) as shown
2. Press out the lower arm with a suitable socket and a hydraulic press, and remove the lower arm from the bushing (C).

REMOVAL / INSTALLATION > FRONT LOWER ARM COMPLIANCE BUSH REMOVAL AND INSTALLATION (2013-18) > INSTALLATION

1. Lower Arm Bushing - Install

1. Clean the mating surfaces of the new bushing and the lower arm
2. Apply a mild soap and water solution to the bushing surface
3. Align the angle of the lower arm (A) and the tab portion (B) of the bushing (C)
4. Press in the bushing by hand first.



NOTE:

1. The installed bushing's tab portion points upward and downward to

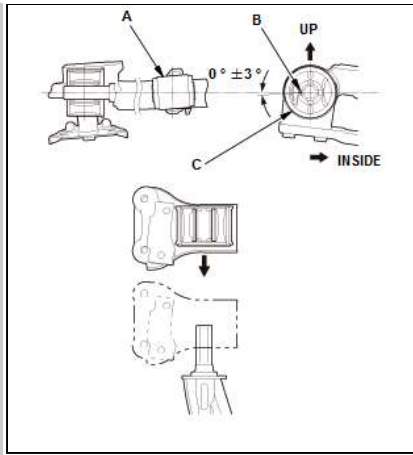

Courtesy of HONDA, U.S.A., INC.

- the installed lower arm.
2. Make sure the up/down direction of the bushing.

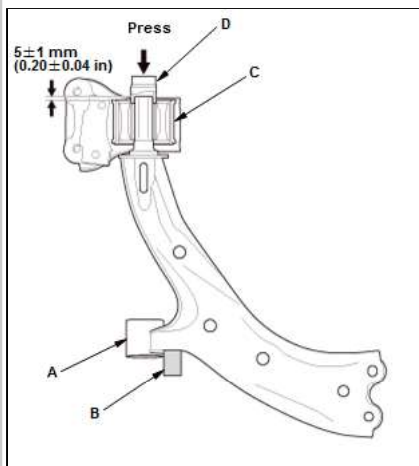

Courtesy of HONDA, U.S.A., INC.

5. Support the lower arm (A) on suitable square lumber (B) as shown
6. Press in the bushing (C) with a suitable socket (D) and a hydraulic press
7. Adjust the distance between the top of the lower arm, and the bushing surface to the dimension shown.

2. Lower Arm - Install

1. Install the lower arm .

3. Front Wheel - Install

1. Install the front wheel .

REMOVAL / INSTALLATION > FRONT LOWER ARM REMOVAL AND INSTALLATION (2013-18) > REMOVAL

1. Vehicle - Lift

1. Raise and support the vehicle .

2. Front Wheel - Remove

1. Remove the front wheel .

3. Stabilizer Bushing Holder - Remove

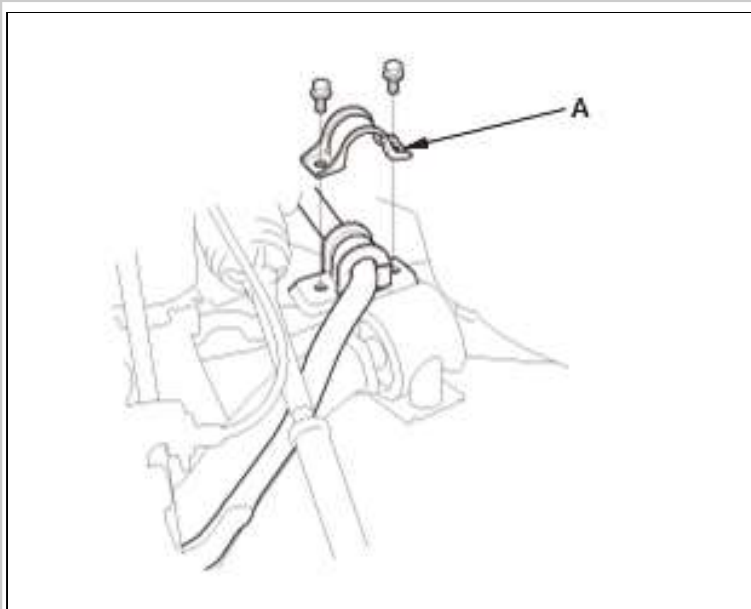

1. Remove the bushing holder (A).

Courtesy of HONDA, U.S.A., INC.

4. Lower Arm Ball Joint - Disconnect

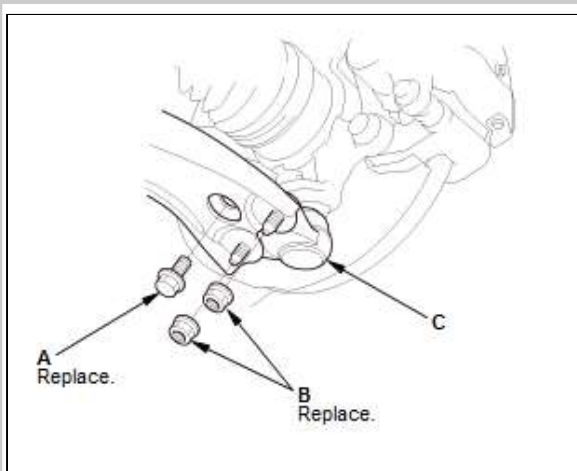

1. Remove the flange bolt (A)
2. Remove the self-locking nuts (B)
3. Disconnect the lower arm ball joint (C) from the lower arm.

Courtesy of HONDA, U.S.A., INC.

5. Engine Undercover - Remove (Left Side Lower Arm)

1. Left Side Lower Arm: Remove the engine undercover - Refer to: Engine Undercover Removal and Installation (2013-15), or Engine Undercover Removal and Installation (2016-18) .

6. Lower Transmission Mount - Remove (Left Side Lower Arm)

1. Left Side Lower Arm: Remove the lower transmission mount - Refer to: Lower Transmission Mount Removal and Installation (2013-18), or Upper Transmission Mount Removal and Installation

(2013-18).

7. Lower Arm - Remove

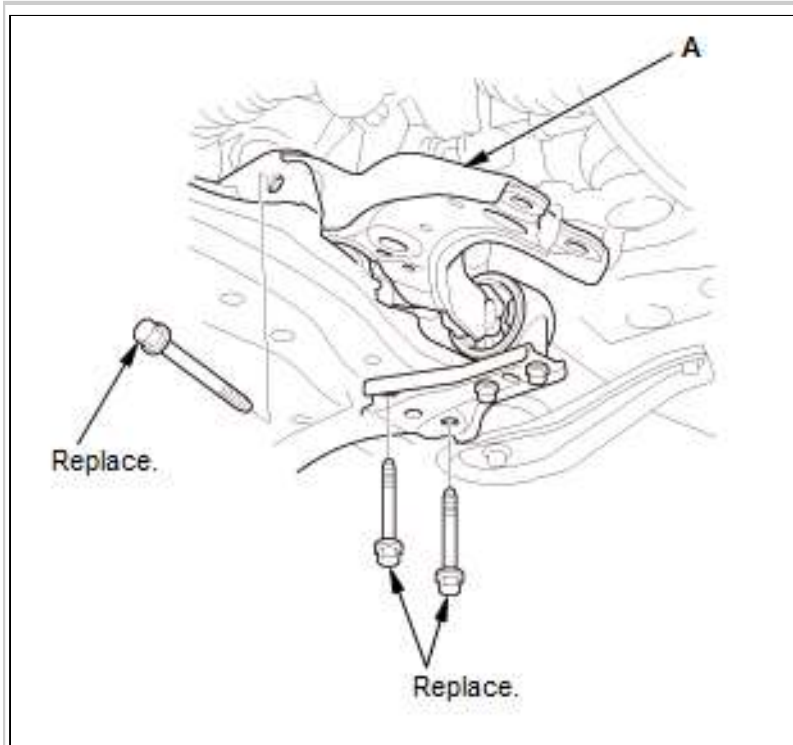

1. Remove the lower arm (A).

Courtesy of HONDA, U.S.A., INC.

REMOVAL / INSTALLATION > FRONT LOWER ARM REMOVAL AND INSTALLATION (2013-18) > INSTALLATION

 **NOTE:** First install all the components, and lightly tighten the bolts and the nuts, then raise the suspension to load it with the vehicle's weight before fully tightening to the specified torque.

1. Lower Arm - Install

Fig 1: Lower Arm Bolt With Torque Specifications

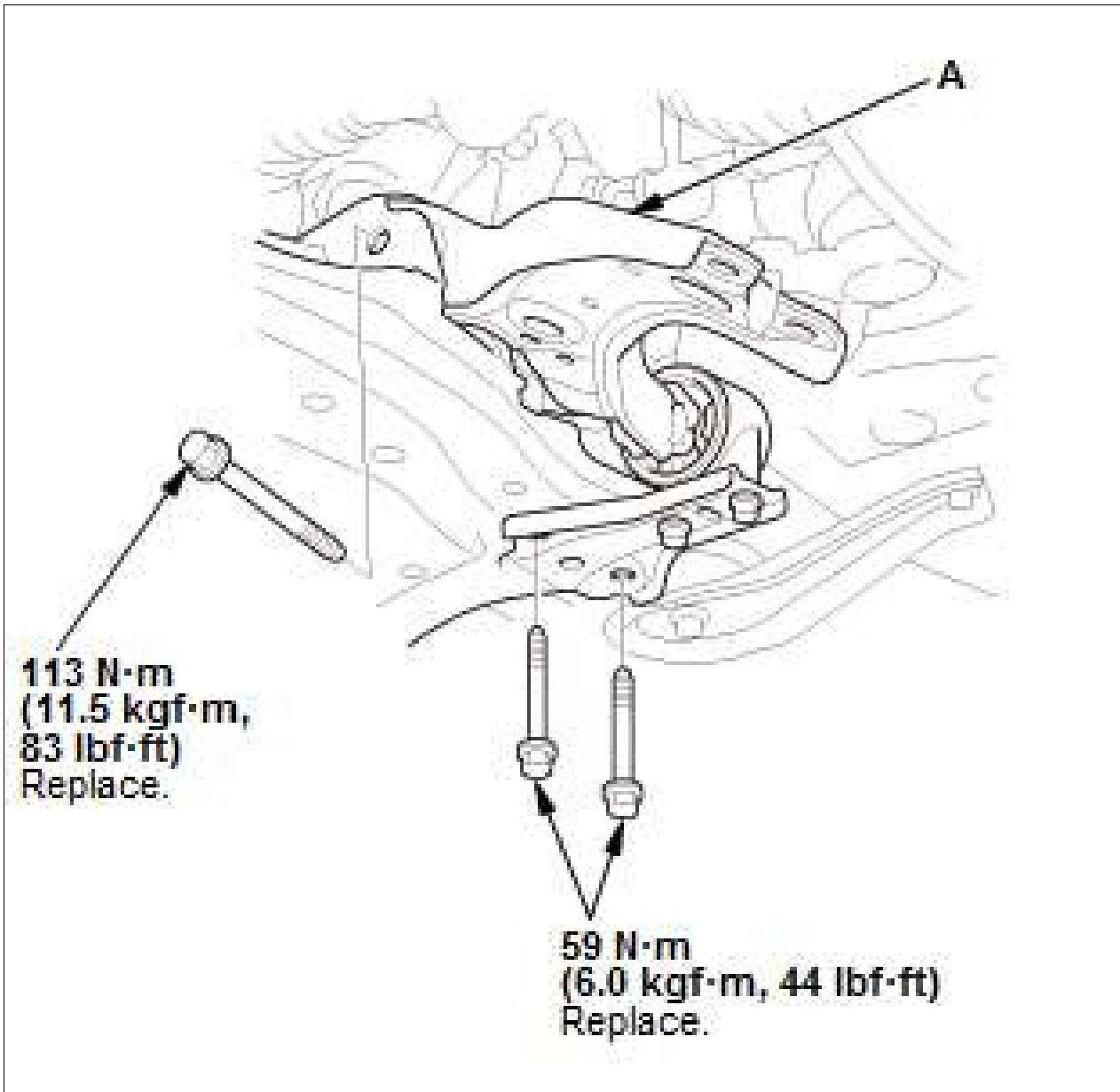

Courtesy of HONDA, U.S.A., INC.

1. Install the lower arm (A) with the new bolts.
2. Lower Transmission Mount - Install (Left Side Lower Arm)

1. Left Side Lower Arm: Install the lower transmission mount - Refer to: Lower Transmission Mount Removal and Installation (2013-18), or Upper Transmission Mount Removal and Installation (2013-18).

3. Engine Undercover - Install (Left Side Lower Arm)

1. Left Side Lower Arm: Install the engine undercover - Refer to: Engine Undercover Removal and Installation (2013-15), or Engine Undercover Removal and Installation (2016-18) .

4. Lower Arm Ball Joint - Connect

Fig 2: Lower Arm Ball Joint Nut With Torque Specifications

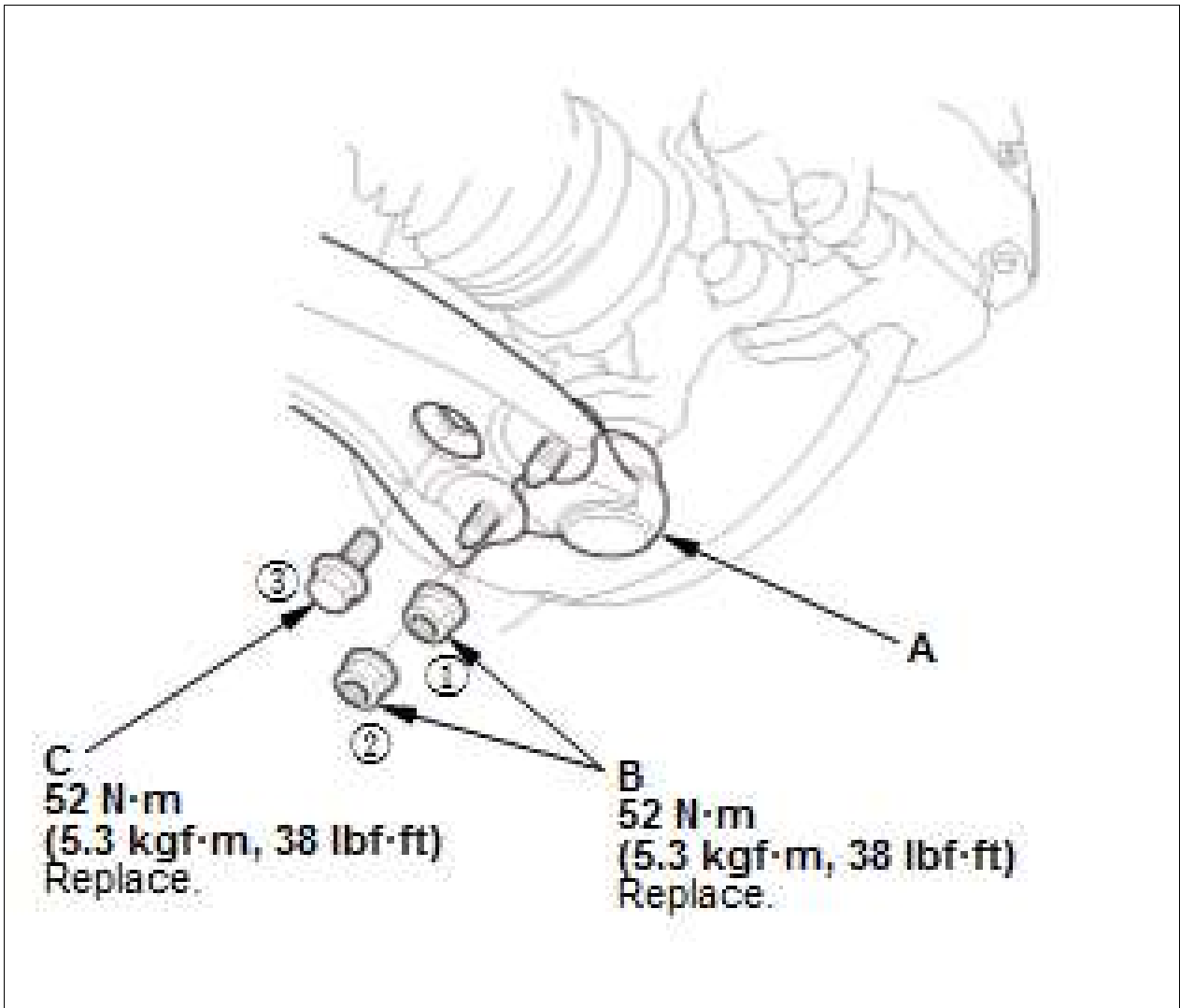

Courtesy of HONDA, U.S.A., INC.

1. Connect the lower arm ball joint (A) to the lower arm
2. Loosely install the new self-locking nuts (B) and the new flange bolt (C)
3. Tighten the self-locking nuts and the flange bolt in the sequence shown.

5. Stabilizer Bushing Holder - Install

	1. Install the bushing holder (A).
--	------------------------------------

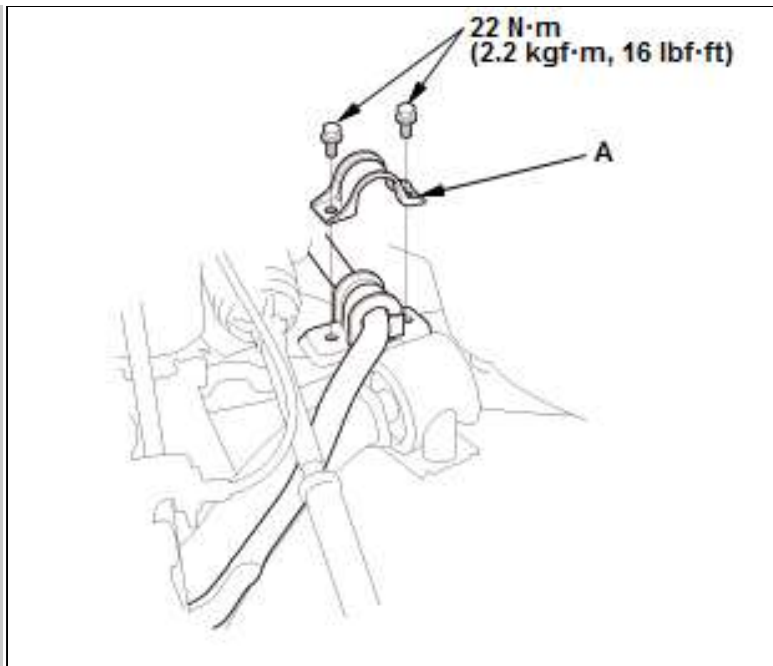

Courtesy of HONDA, U.S.A., INC.

6. Front Wheel - Install

	1. Install the front wheel .
--	------------------------------

7. Wheel Alignment - Check

	1. Check the wheel alignment, and adjust it if necessary .
--	--

REMOVAL / INSTALLATION > FRONT STABILIZER BAR REMOVAL AND INSTALLATION (2013-18) > REMOVAL

1. Vehicle - Lift

	1. Raise and support the vehicle .
--	------------------------------------

2. Front Wheels - Remove

	1. Remove both front wheels .
--	-------------------------------

3. Stabilizer Link - Disconnect

	1. Disconnect both sides of the stabilizer link from the stabilizer bar .
--	---

4. Stabilizer Bar - Remove

	1. Remove the bushing holders (A) 2. Remove the bushings (B)
--	---

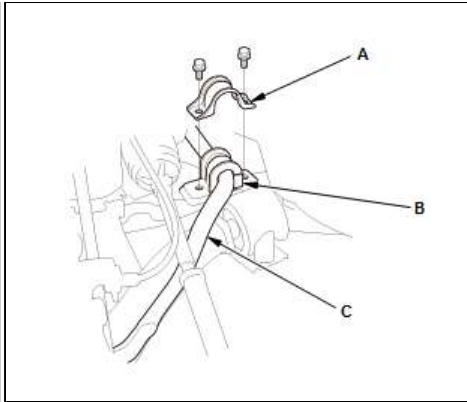

Courtesy of HONDA, U.S.A., INC.

3. Move the stabilizer bar (C) toward the passenger's side, and remove the stabilizer bar.

NOTE: Be careful not to damage the steering gearbox.

REMOVAL / INSTALLATION > FRONT STABILIZER BAR REMOVAL AND INSTALLATION (2013-18) > INSTALLATION

1. Stabilizer Bar - Install

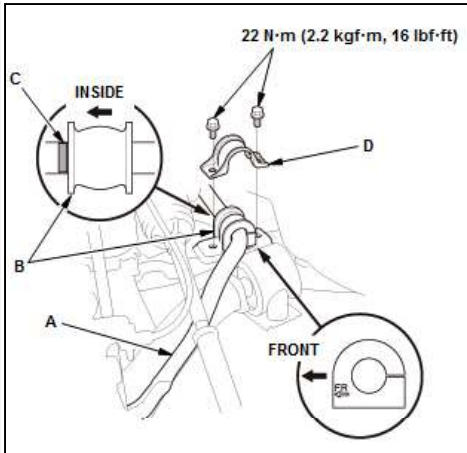

Courtesy of HONDA, U.S.A., INC.

1. Install the stabilizer bar (A).

NOTE: Be careful not to damage the steering gearbox

2. Install the bushings (B).

NOTE:

1. Note the direction of installation for the bushing.
2. Align the paint mark (C) on the stabilizer bar with the side of the bushing.

3. Install the bushing holders (D).

2. Stabilizer Link - Connect

1. Connect both sides of the stabilizer link to the stabilizer bar .

3. Front Wheels - Install

1. Install both front wheels .

REMOVAL / INSTALLATION > FRONT STABILIZER LINK REMOVAL AND INSTALLATION (2013-18) > REMOVAL

1. Vehicle - Lift

1. Raise and support the vehicle .

2. Front Wheel - Remove

1. Remove the front wheel .

3. Stabilizer Link - Remove

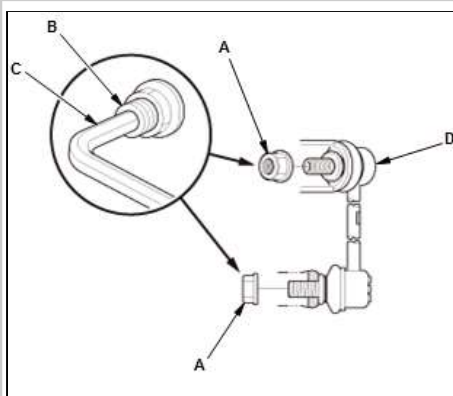

1. Remove the flange nuts (A) while holding the respective joint pin (B) with a hex wrench (C)
2. Remove the stabilizer link (D).

Courtesy of HONDA, U.S.A., INC.

REMOVAL / INSTALLATION > FRONT STABILIZER LINK REMOVAL AND INSTALLATION (2013-18) > INSTALLATION

1. Stabilizer Link - Install

Fig 1: Stabilizer Link Nuts With Torque Specifications

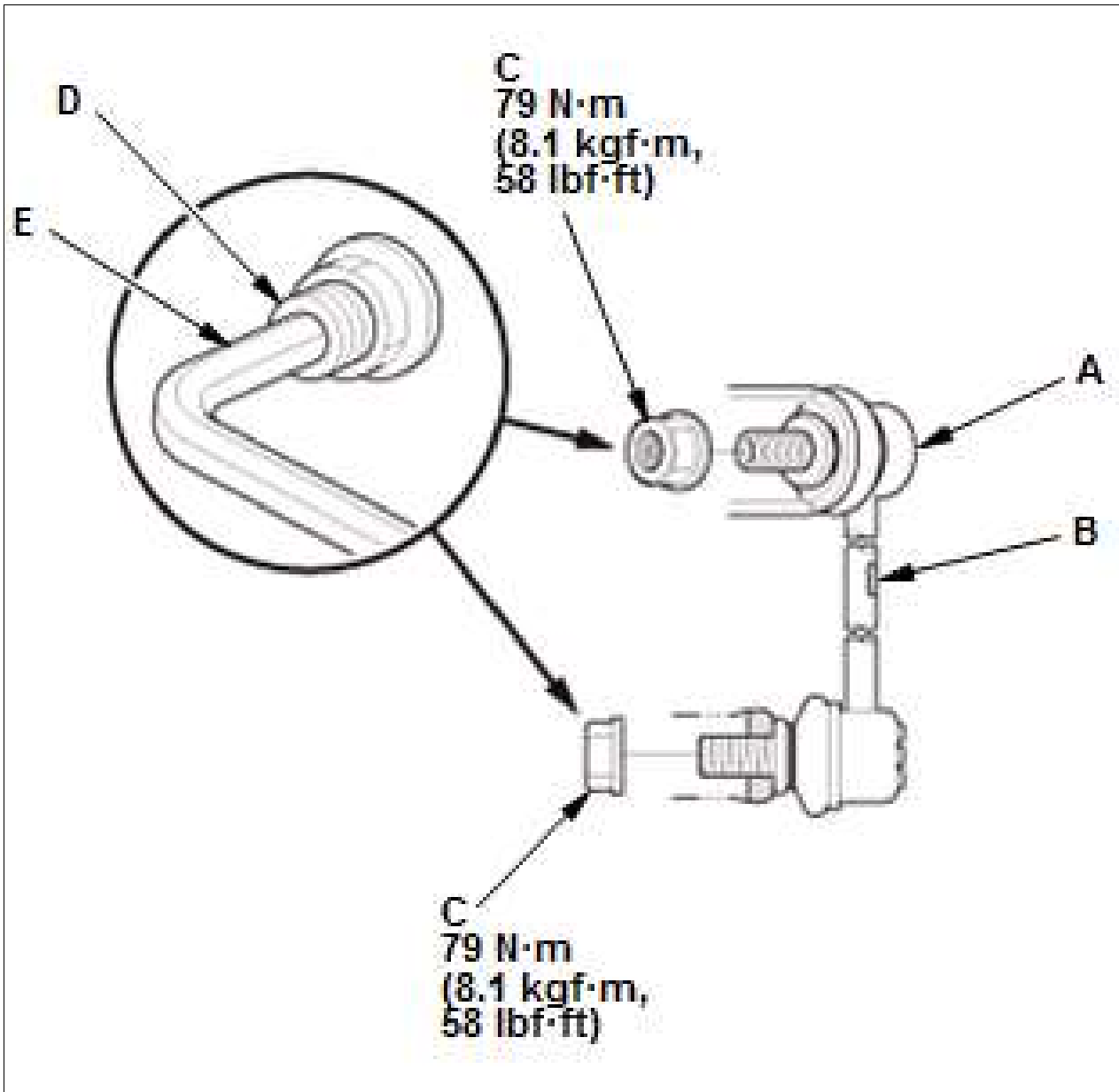

Courtesy of HONDA, U.S.A., INC.

1. Install the stabilizer link (A).

 **NOTE:** The stabilizer link has a paint mark (B). The left stabilizer link is marked with yellow paint, and the right stabilizer link is marked with white paint

2. Install the flange nuts (C), and tighten them to the specified torque while holding the respective joint pin (D) with a hex wrench (E).

2. Front Wheel - Install



1. Install the front wheel .

REMOVAL / INSTALLATION > REAR DAMPER REMOVAL, INSTALLATION, AND INSPECTION (2013-18) > EXPLODED / VIEW

Fig 1: Exploded View Of Rear Damper With Torque Specifications

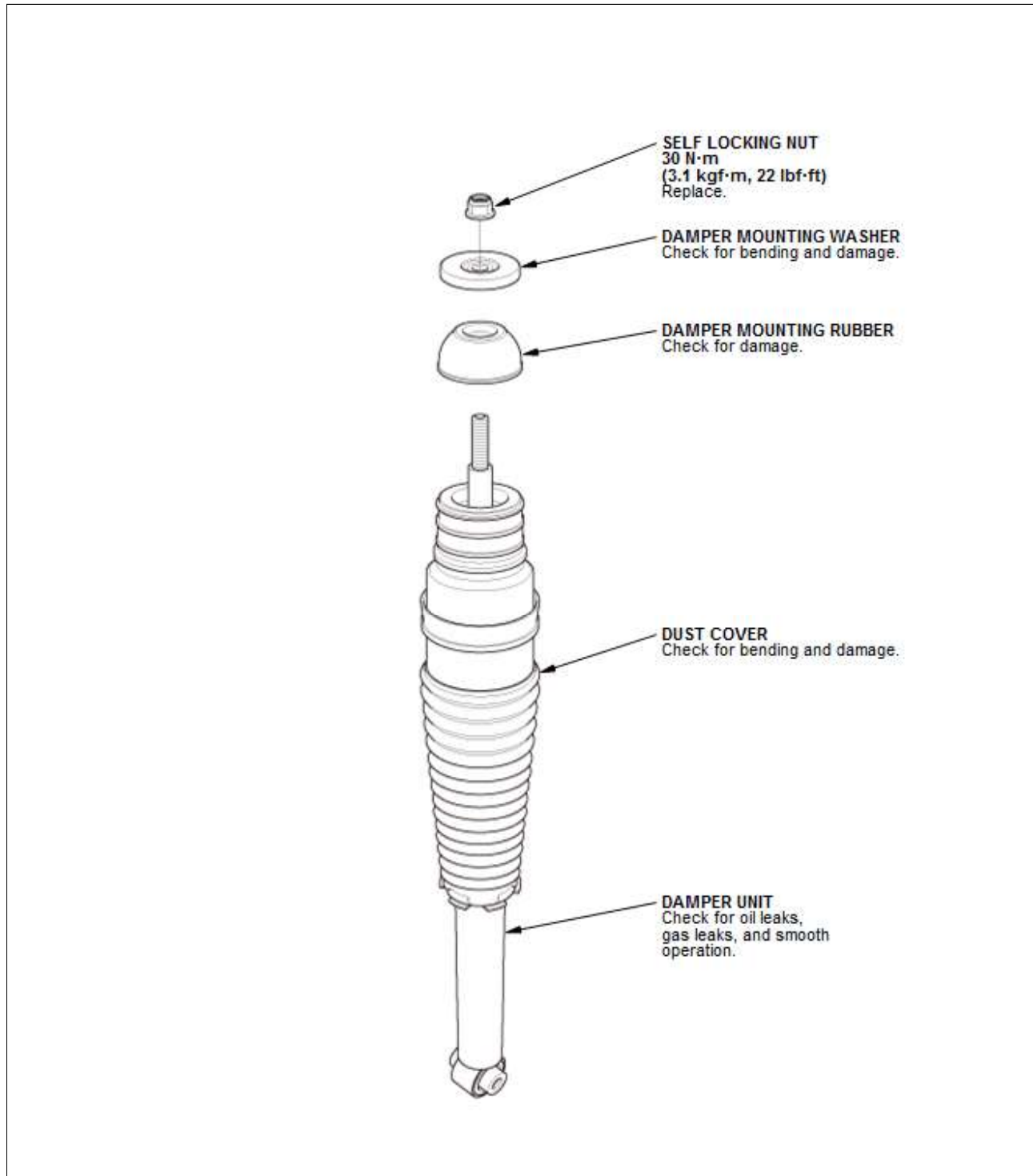

REMOVAL / INSTALLATION > REAR DAMPER REMOVAL, INSTALLATION, AND INSPECTION (2013-18) > REMOVAL



NOTE: Refer to the Exploded View as needed during the following procedures.

1. Vehicle - Lift

1. Raise and support the vehicle .

2. Rear Wheel - Remove

1. Remove the rear wheel .

3. Lower Arm B - Support

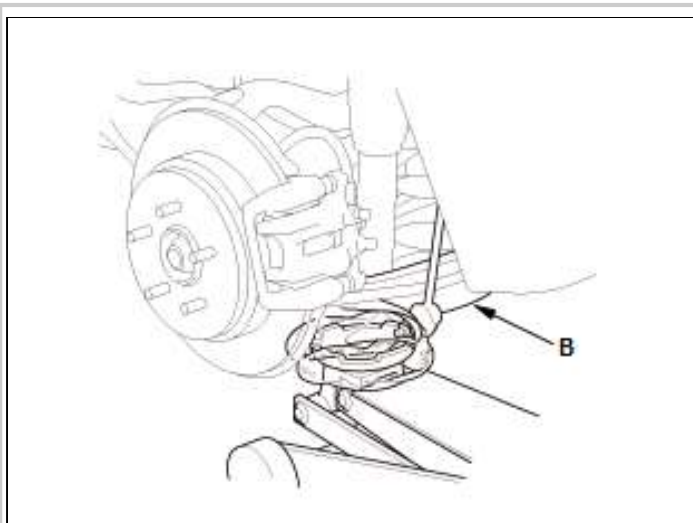

Courtesy of HONDA, U.S.A., INC.

1. Position a floor jack under lower arm B.

4. Damper - Remove

1. Raise the floor jack until the suspension begins to compress
2. Remove the damper mounting bolt (A).

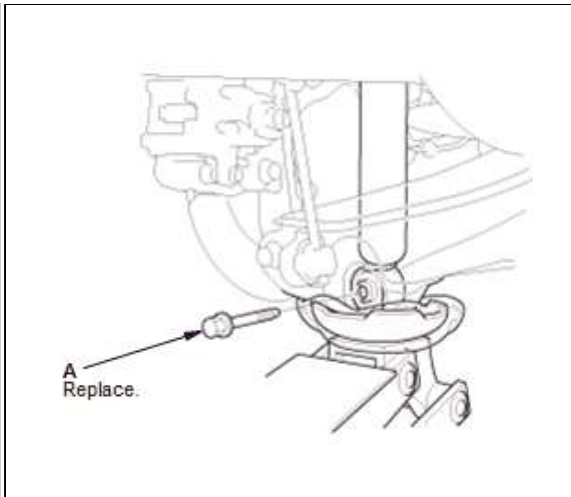

Courtesy of HONDA, U.S.A., INC.

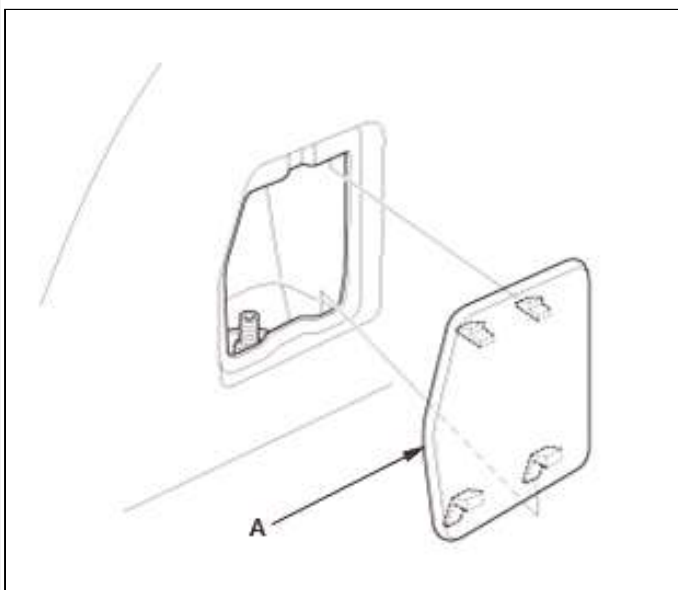

3. Remove the damper maintenance lid (A).

Courtesy of HONDA, U.S.A., INC.

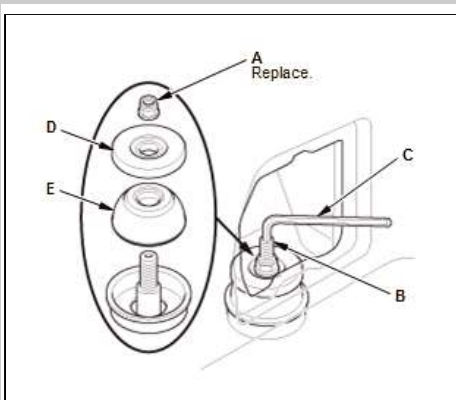

4. Remove the self-locking nut (A) while holding the damper shaft (B) with a hex wrench (C)

5. Remove the damper mounting washer (D)

6. Remove the damper mounting rubber (E).

Courtesy of HONDA, U.S.A., INC.

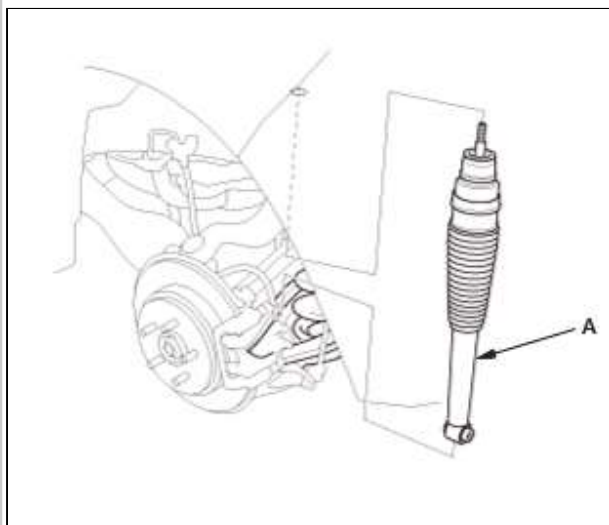

Courtesy of HONDA, U.S.A., INC.

7. Remove the damper unit (A).

NOTE: Be careful not to damage the body.

REMOVAL / INSTALLATION > REAR DAMPER REMOVAL, INSTALLATION, AND INSPECTION (2013-18) > INSPECTION

1. Rear Damper - Inspect

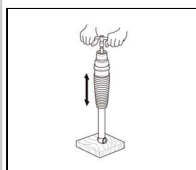

Courtesy of HONDA, U.S.A., INC.

1. Install the flange nut on the damper shaft end, and set the socket wrench and T-handle on the nut
2. Compress the damper assembly by hand, and check for smooth operation through a full stroke, both compression and extension. The damper should extend smoothly and constantly when compression is released. If it does not, the gas is leaking and the damper should be replaced
3. Check for oil leaks, abnormal noises, and binding during these tests.

REMOVAL / INSTALLATION > REAR DAMPER REMOVAL, INSTALLATION, AND INSPECTION (2013-18) > INSTALLATION

NOTE: Refer to the Exploded View as needed during the following procedures.

1. Damper - Install

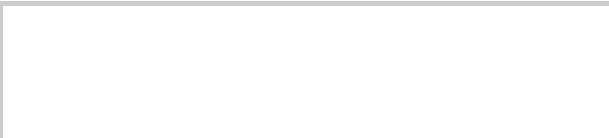

1. Install the damper unit (A).

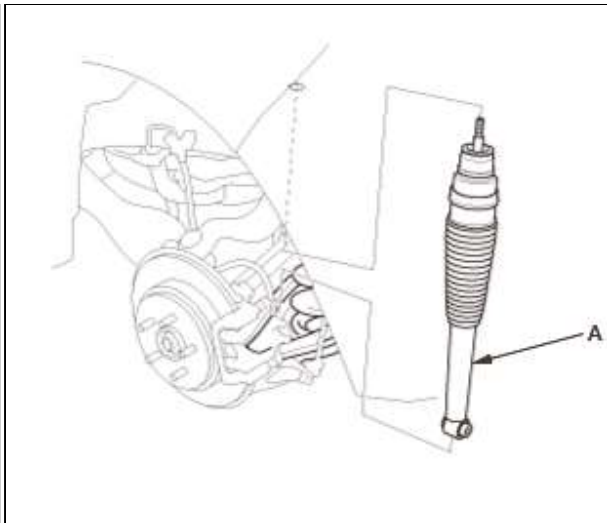

 **NOTE:** Be careful not to damage the body.

Courtesy of HONDA, U.S.A., INC.

Fig 1: Rear Damper Bolt With Torque Specifications

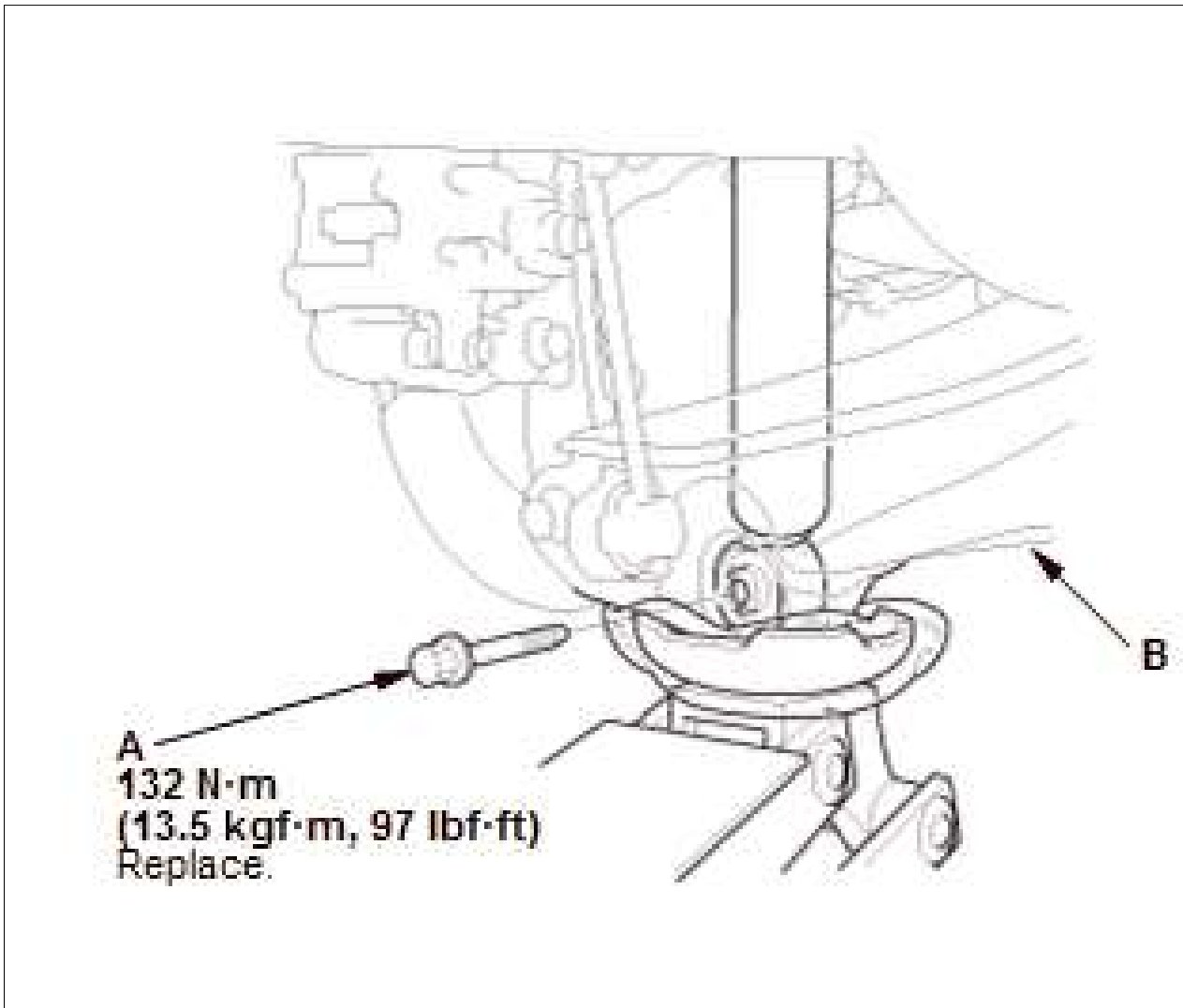

Courtesy of HONDA, U.S.A., INC.

2. Position a floor jack under lower arm B to support the suspension
3. Slowly raise the floor jack until you align the bolt hole with the holes in lower arm B and the damper
4. Loosely install the new flange bolt (A)
5. Raise the rear suspension with the jack until the vehicle just lifts off of the safety stands, then tighten the damper mounting bolt to the specified torque.

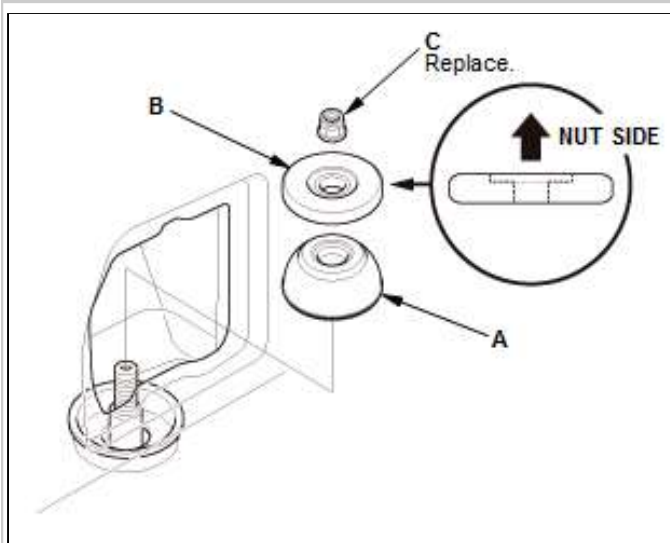

6. Install the damper mounting rubber (A)
7. Install the damper mounting washer (B)
8. Loosely install the new self-locking nut (C).

Courtesy of HONDA, U.S.A., INC.

Fig 2: Rear Damper Nut With Torque Specifications

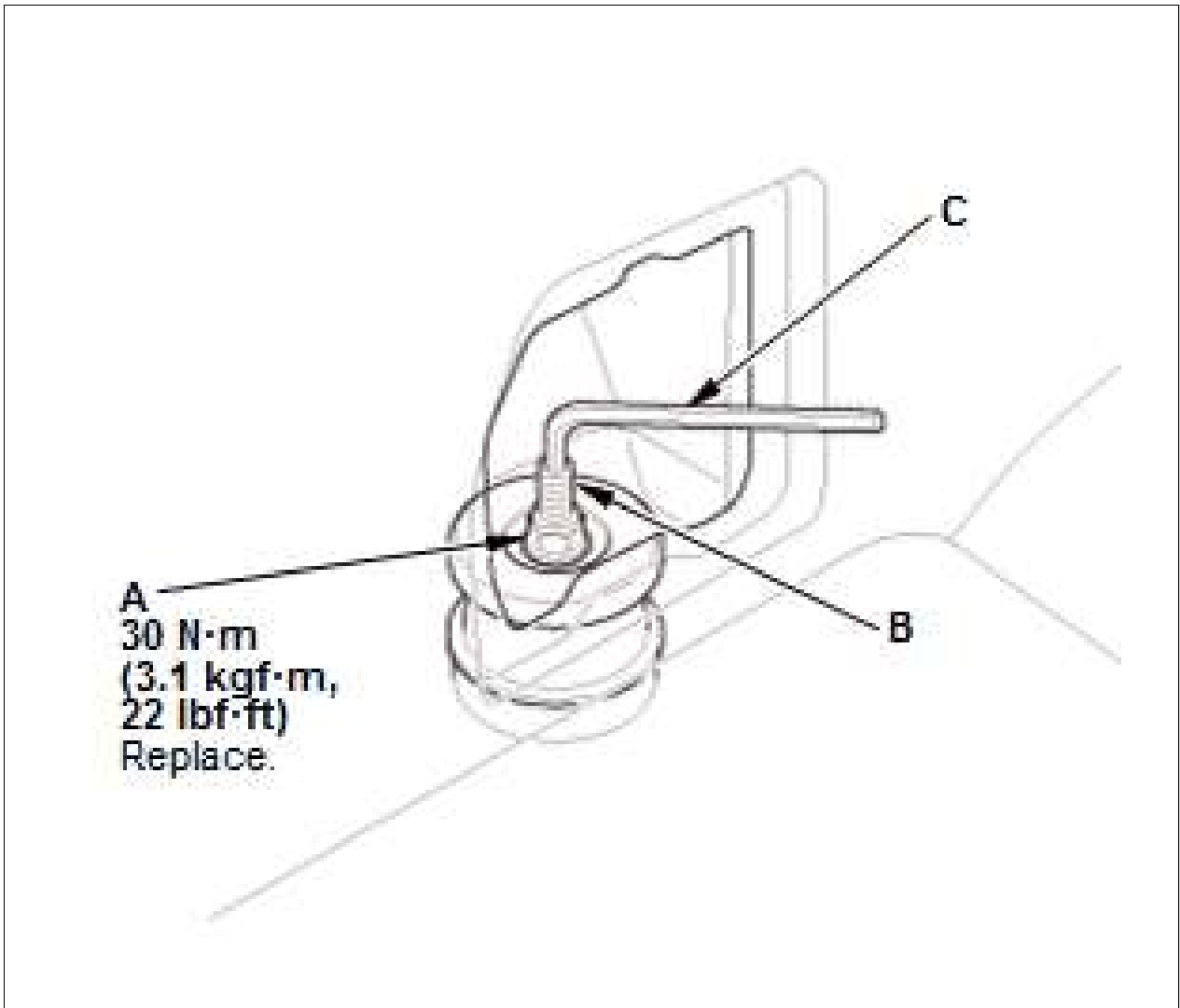

Courtesy of HONDA, U.S.A., INC.

9. Tighten the self-locking nut (A) to the specified torque while holding the damper shaft (B) with a hex wrench (C).

10. Install the damper maintenance lid (A).

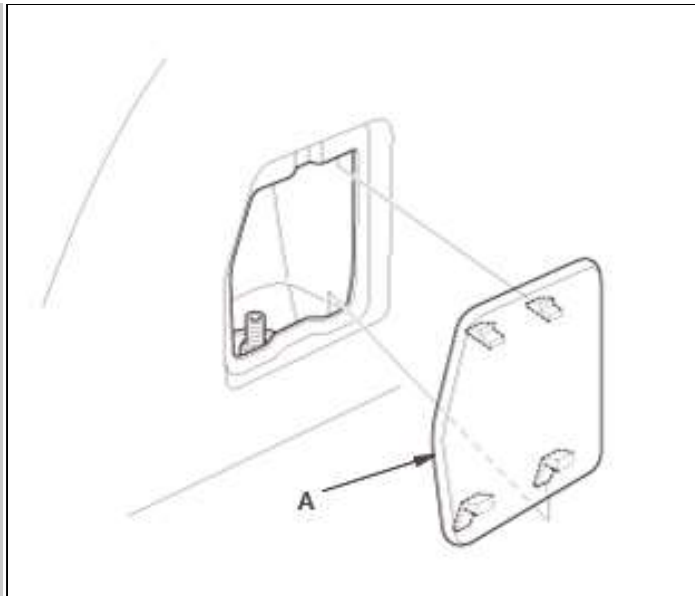

Courtesy of HONDA, U.S.A., INC.

2. Rear Wheel - Install

1. Install the rear wheel .

3. Wheel Alignment - Check

1. Check the wheel alignment, and adjust it if necessary .

REMOVAL / INSTALLATION > REAR KNUCKLE/HUB BEARING UNIT REMOVAL AND INSTALLATION (2013-15)

Special Tools Required

Image	Description/Tool Number
	Ball Joint Thread Protector, 12 mm 07AAF-SDAA100

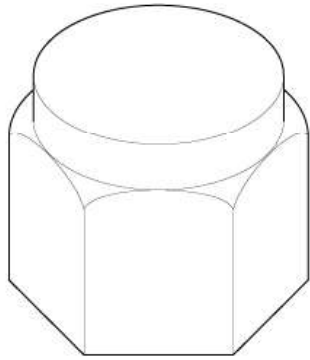

Courtesy of HONDA, U.S.A., INC.



Ball Joint Remover, 32 mm 07MAC-SL00102

Courtesy of HONDA, U.S.A., INC.

**REMOVAL / INSTALLATION > REAR KNUCKLE/HUB BEARING UNIT REMOVAL AND
INSTALLATION (2013-15) > EXPLODED / VIEW**

Fig 1: Exploded View Of Rear Knuckle/Hub Bearing Unit With Torque Specifications

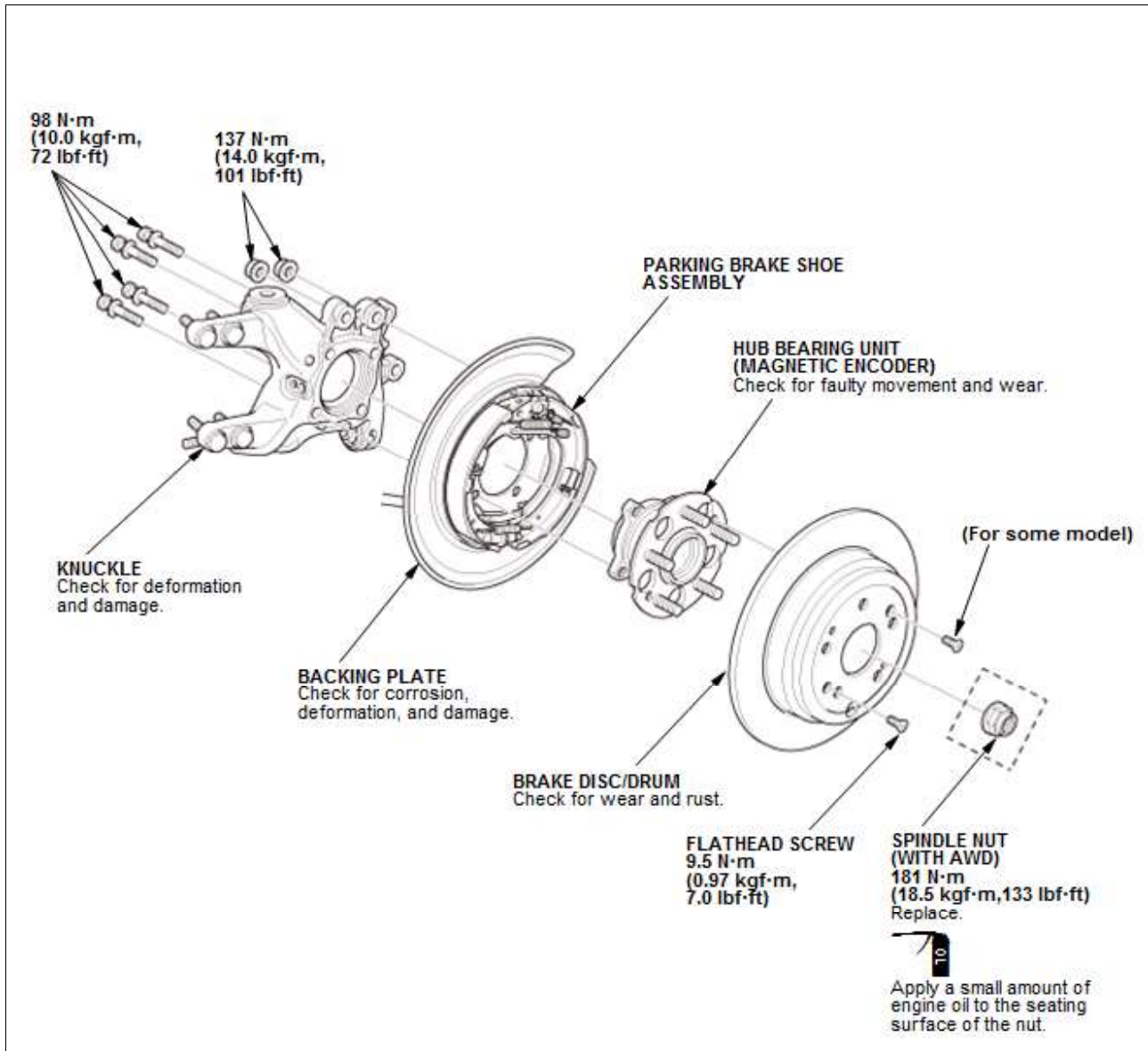

Courtesy of HONDA, U.S.A., INC.

REMOVAL / INSTALLATION > REAR KNUCKLE/HUB BEARING UNIT REMOVAL AND INSTALLATION (2013-15) > REMOVAL

NOTE:

- Refer to the Exploded View as needed during the following procedures.
- The illustrations show AWD model; the 2WD model is similar.

Hub Bearing Unit

1. Vehicle - Lift

1. Raise and support the vehicle .

2. Rear Wheel - Remove

1. Remove the rear wheel .

3. Rear Brake Caliper - Remove

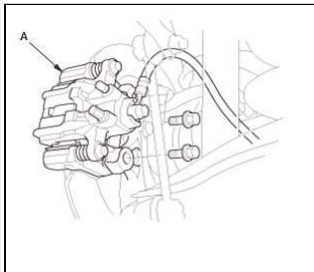

Courtesy of HONDA, U.S.A., INC.

1. Remove the caliper assembly (A).



NOTE:

1. To prevent damage to the caliper assembly or brake hose, use a short piece of wire to hang the caliper assembly from the undercarriage.
2. Do not twist the brake hose excessively.

4. Rear Spindle Nut - Remove (AWD)

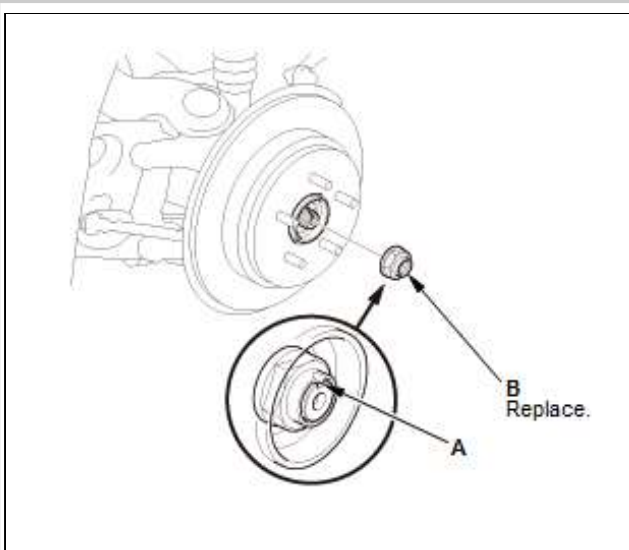

Courtesy of HONDA, U.S.A., INC.

1. AWD: Pry up the stake (A) on the spindle nut (B)
2. AWD: Remove the spindle nut.

5. Rear Brake Disc/Drum - Remove

1. Remove the brake disc/drum .

6. Hub Bearing Unit - Remove

2WD

1. 2WD: Remove the hub bearing unit (A).

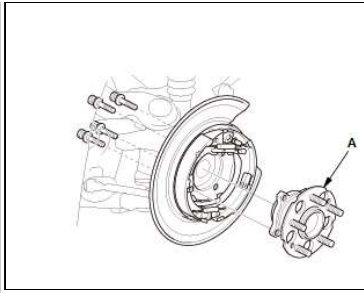

Courtesy of HONDA, U.S.A., INC.

 **NOTE:** Keep the wheel bearing/encoder away from any magnetic field. The encoder can be damaged or erased.

AWD

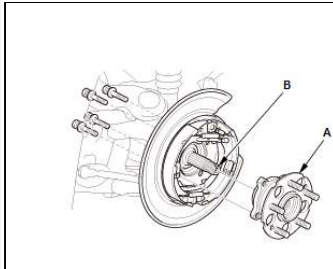

Courtesy of HONDA, U.S.A., INC.

2. AWD: Remove the hub bearing unit (A) by tapping the driveshaft end (B) with a soft face hammer while drawing the hub bearing unit outward.

 **NOTE:** Keep the wheel bearing/encoder away from any magnetic field. The encoder can be damaged or erased.

7. Hub Bearing Unit for Damage and Cracks - Check

1. Check the hub bearing unit for damage and cracks.

Knuckle

8. Backing Plate - Remove

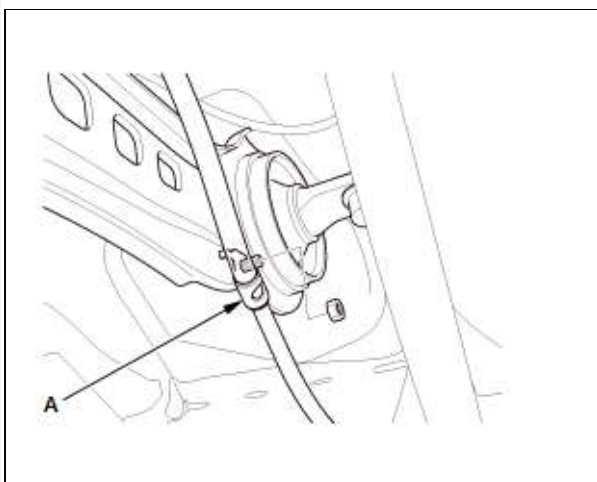

Courtesy of HONDA, U.S.A., INC.

1. Remove the parking brake cable mounting bracket (A).

2. Remove the backing plate (A).

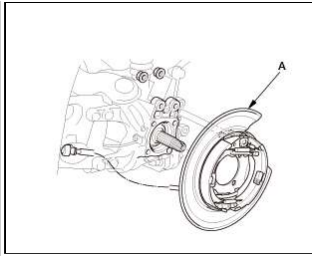

Courtesy of HONDA, U.S.A., INC.

NOTE:

1. To prevent damage to the backing plate or parking brake cable, use a short piece of wire to hang the backing plate from the undercarriage.
2. Do not twist the parking brake cable excessively.

9. Rear Wheel Speed Sensor - Remove

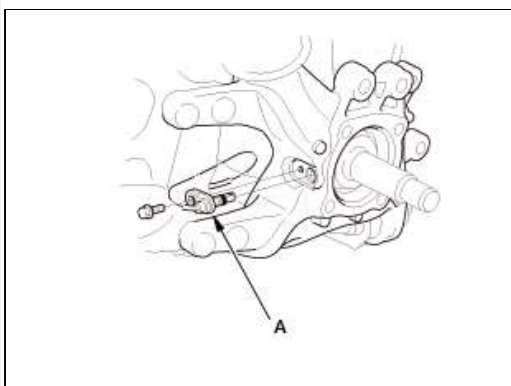

Courtesy of HONDA, U.S.A., INC.

1. Remove the wheel speed sensor (A).

NOTE: Do not disconnect the wheel speed sensor connector.

10. Upper Arm Ball Joint - Disconnect

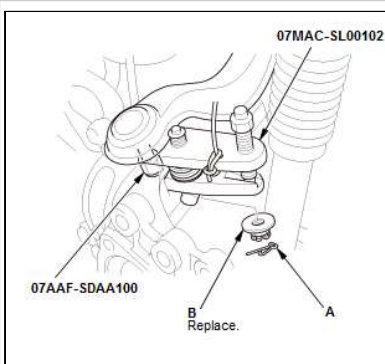

Courtesy of HONDA, U.S.A., INC.

1. Remove the lock pin (A).
2. Remove the castle nut (B).
3. Disconnect the upper arm ball joint from the knuckle using the ball joint thread protector and the ball joint remover .

NOTE: Be careful not to damage the ball joint boot when installing the ball joint remover.

11. Lower Arm A - Remove

1. Remove the flange nut (B), the washer (C), and the flange bolt (D)
2. Remove the lower arm A
3. Remove the washer (E).

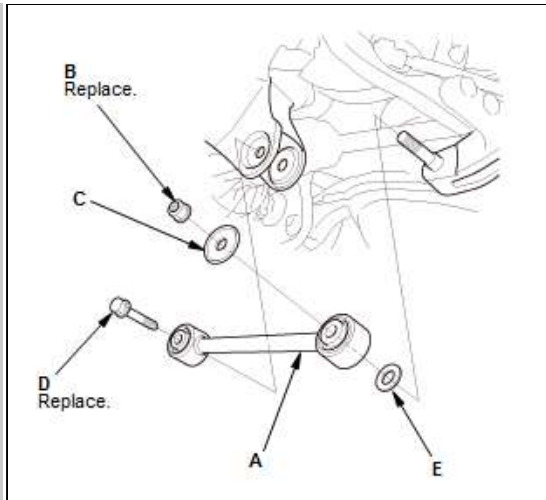

Courtesy of HONDA, U.S.A., INC.

12. Knuckle - Remove

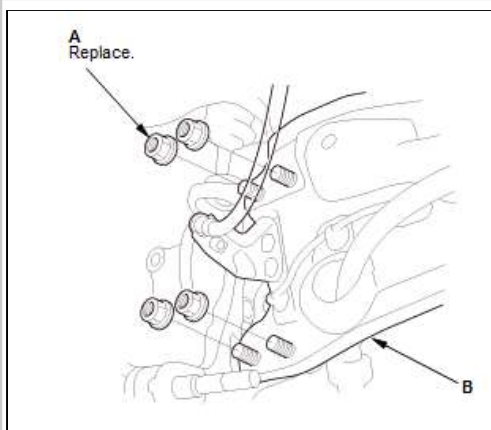

Courtesy of HONDA, U.S.A., INC.

1. Remove the flange nuts (A), and separate the knuckle from the trailing arm (B).

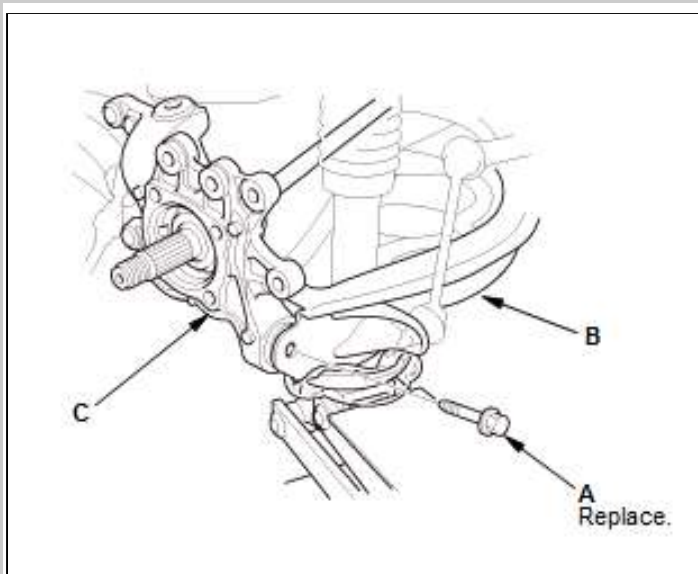

2. Position a floor jack under lower arm B
 3. Remove the flange bolt (A)
 4. Remove the knuckle (C).

REMOVAL / INSTALLATION > REAR KNUCKLE/HUB BEARING UNIT REMOVAL AND INSTALLATION (2013-15) > INSTALLATION



NOTE:

- *Refer to the Exploded View as needed during the following procedures.*
- *First install all the components, and lightly tighten the bolts and the nuts, then raise the suspension to load it with the vehicle's weight before fully tightening to the specified torque.*
- *The illustrations show AWD model; the 2WD model is similar.*

Knuckle

1. Knuckle - Install

Fig 1: Knuckle Bolt With Torque Specifications

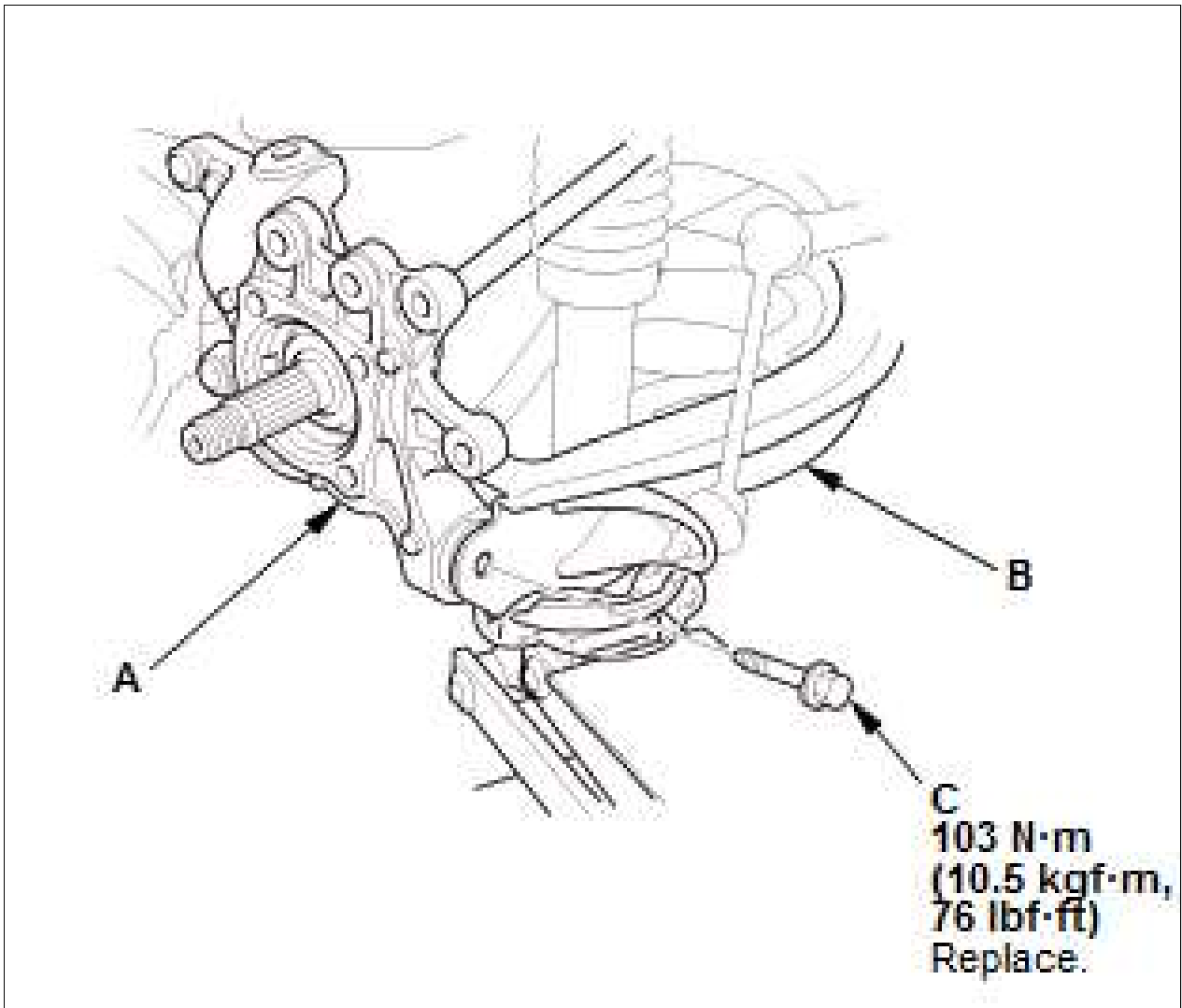

Courtesy of HONDA, U.S.A., INC.

1. Install the knuckle (A) to the lower arm B
2. Install the new flange bolt (C).

Fig 2: Trailing Arm With Torque Specifications

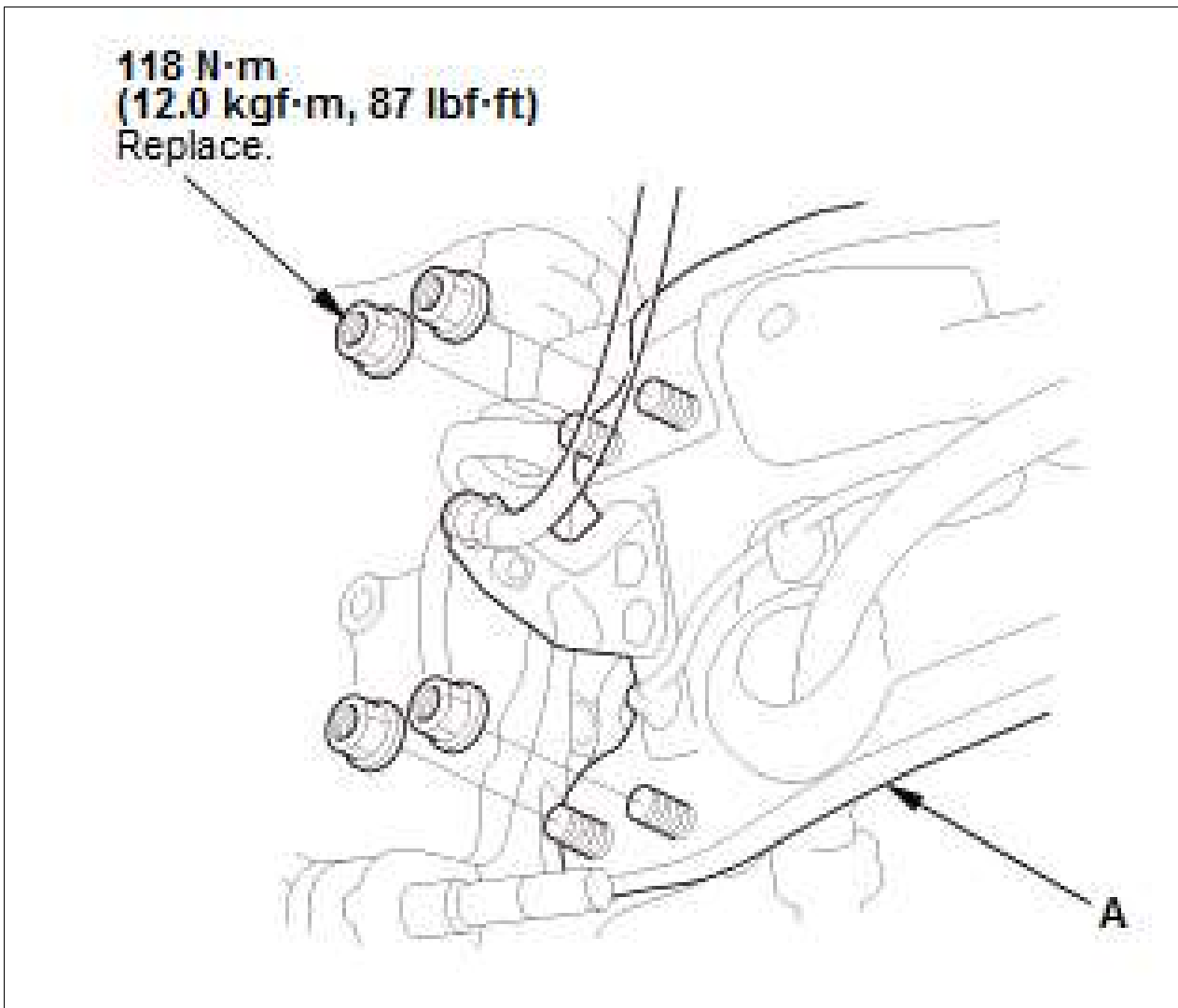

Courtesy of HONDA, U.S.A., INC.

3. Install the trailing arm (A) to the knuckle.
2. Lower Arm A - Install

Fig 3: Lower Arm A With Torque Specifications

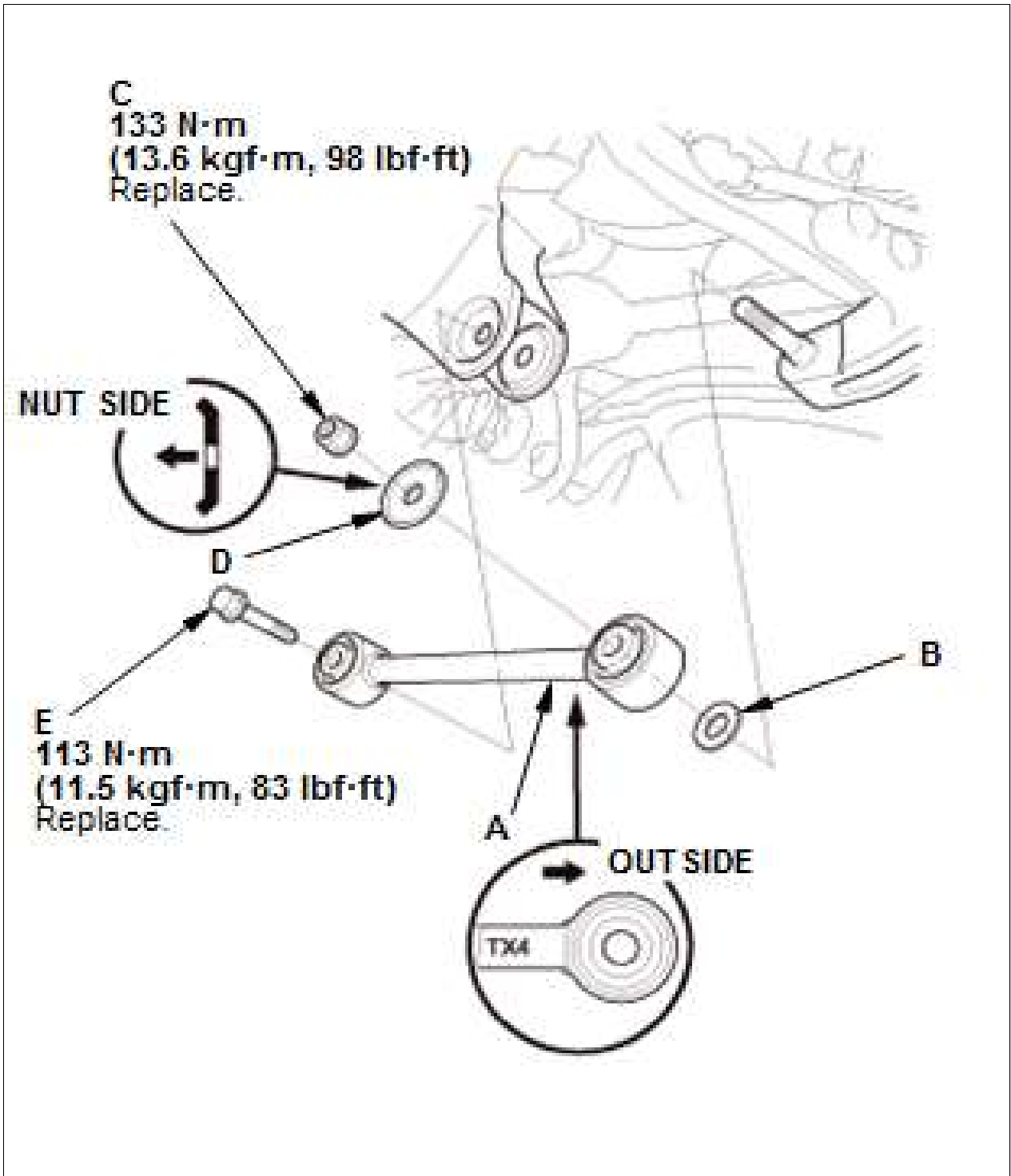

Courtesy of HONDA, U.S.A., INC.

1. Install the washer (B)
 2. Install the lower arm A
 3. Install the new flange nut (C), the washer (D), and the new flange bolt (E).
3. Upper Arm Ball Joint - Connect

Fig 4: Upper Arm Ball Joint With Torque Specifications

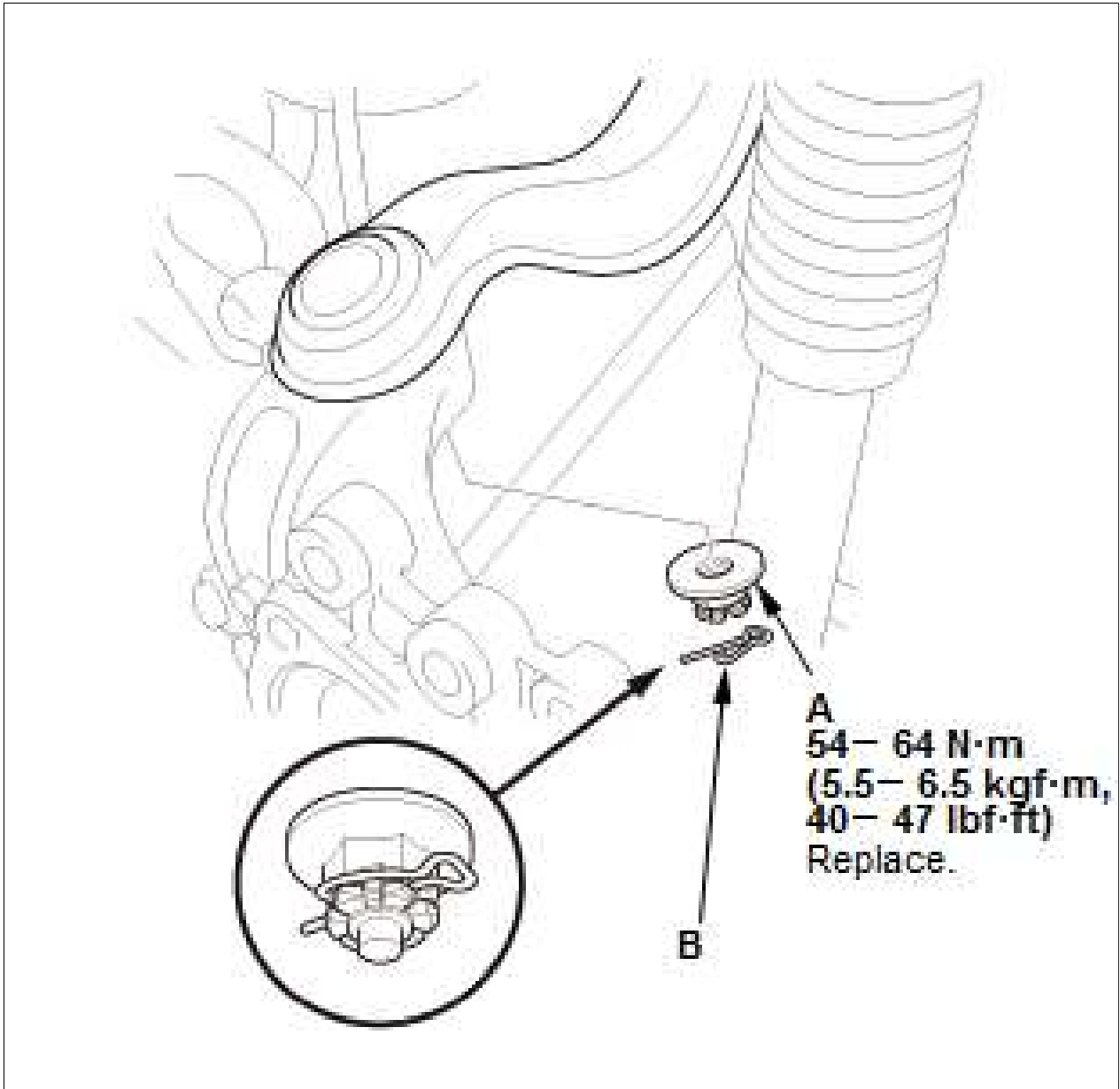

Courtesy of HONDA, U.S.A., INC.

1. Connect the upper arm ball joint to the knuckle
2. Install the new castle nut (A).

 **NOTE:** Torque the castle nut to the lower torque specification, then tighten it only far enough to align the slot with the ball joint pin hole. Do not align the castle nut by loosening it

3. Install the lock pin (B) as shown.
4. Rear Wheel Speed Sensor - Install

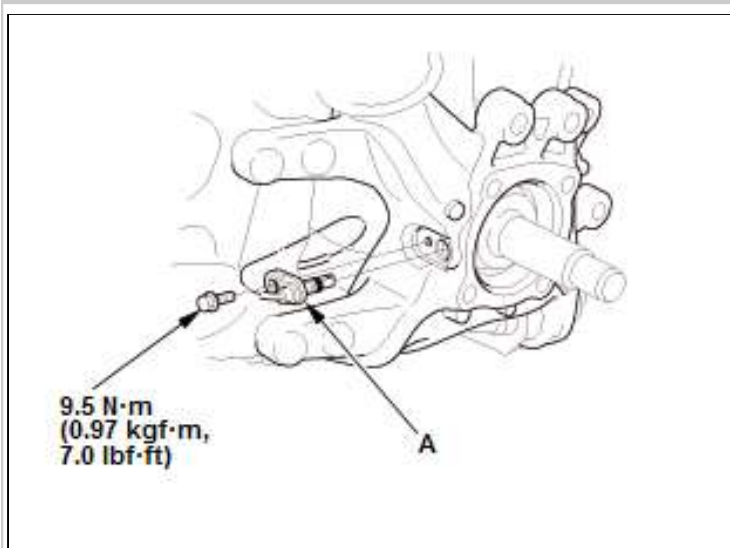

1. Install the wheel speed sensor (A).

Courtesy of HONDA, U.S.A., INC.

5. Backing Plate - Install

Fig 5: Backing Plate With Torque Specifications

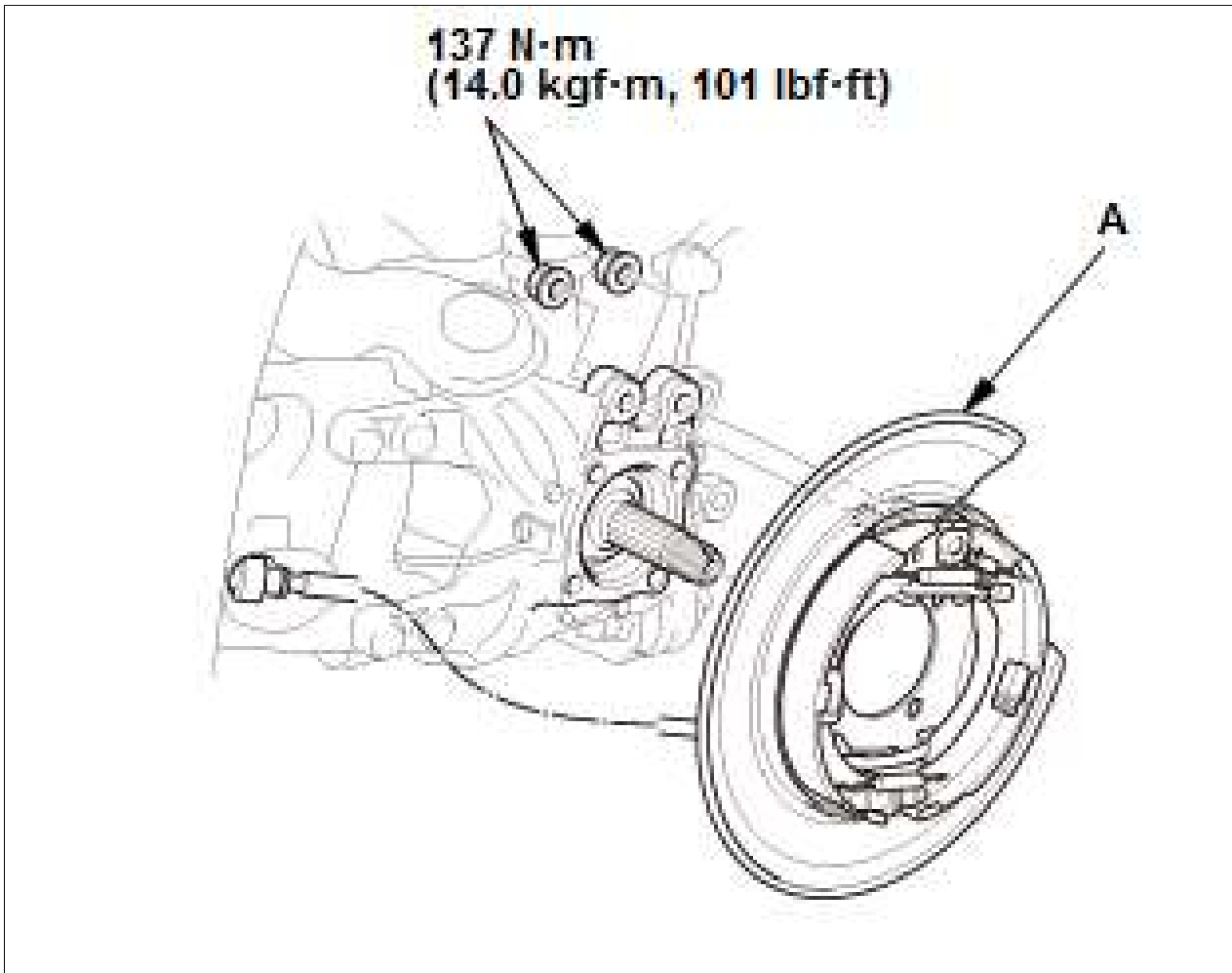

Courtesy of HONDA, U.S.A., INC.

1. Install the backing plate (A).

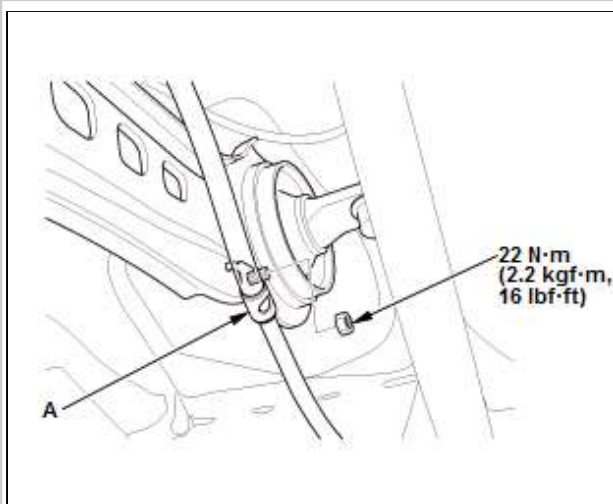

2. Install the parking brake cable mounting bracket (A).

Courtesy of HONDA, U.S.A., INC.

Hub Bearing Unit

6. Hub Bearing Unit - Install

Fig 6: 2WD Hub Bearing Unit With Torque Specifications

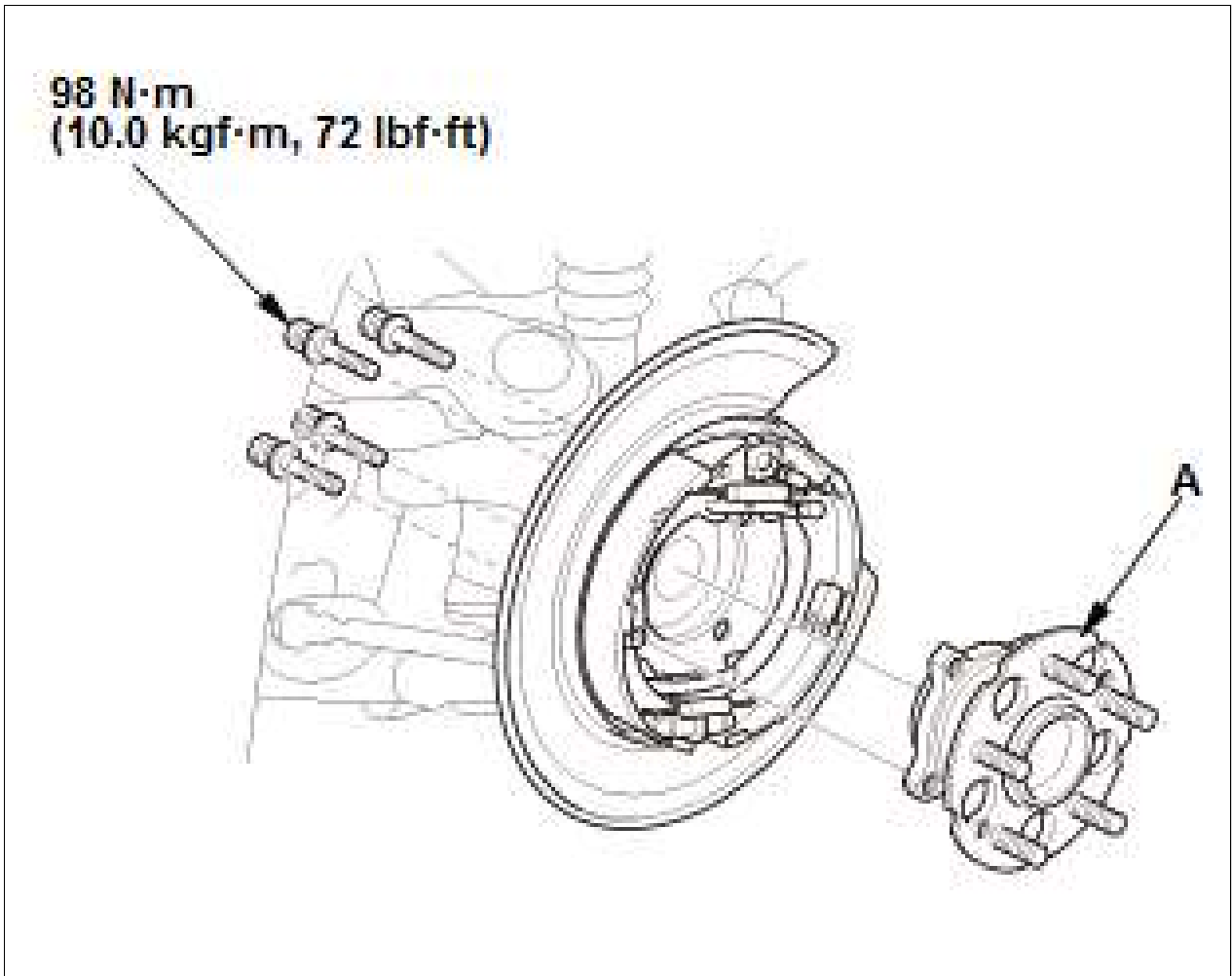

Courtesy of HONDA, U.S.A., INC.

Fig 7: AWD Hub Bearing Unit With Torque Specifications

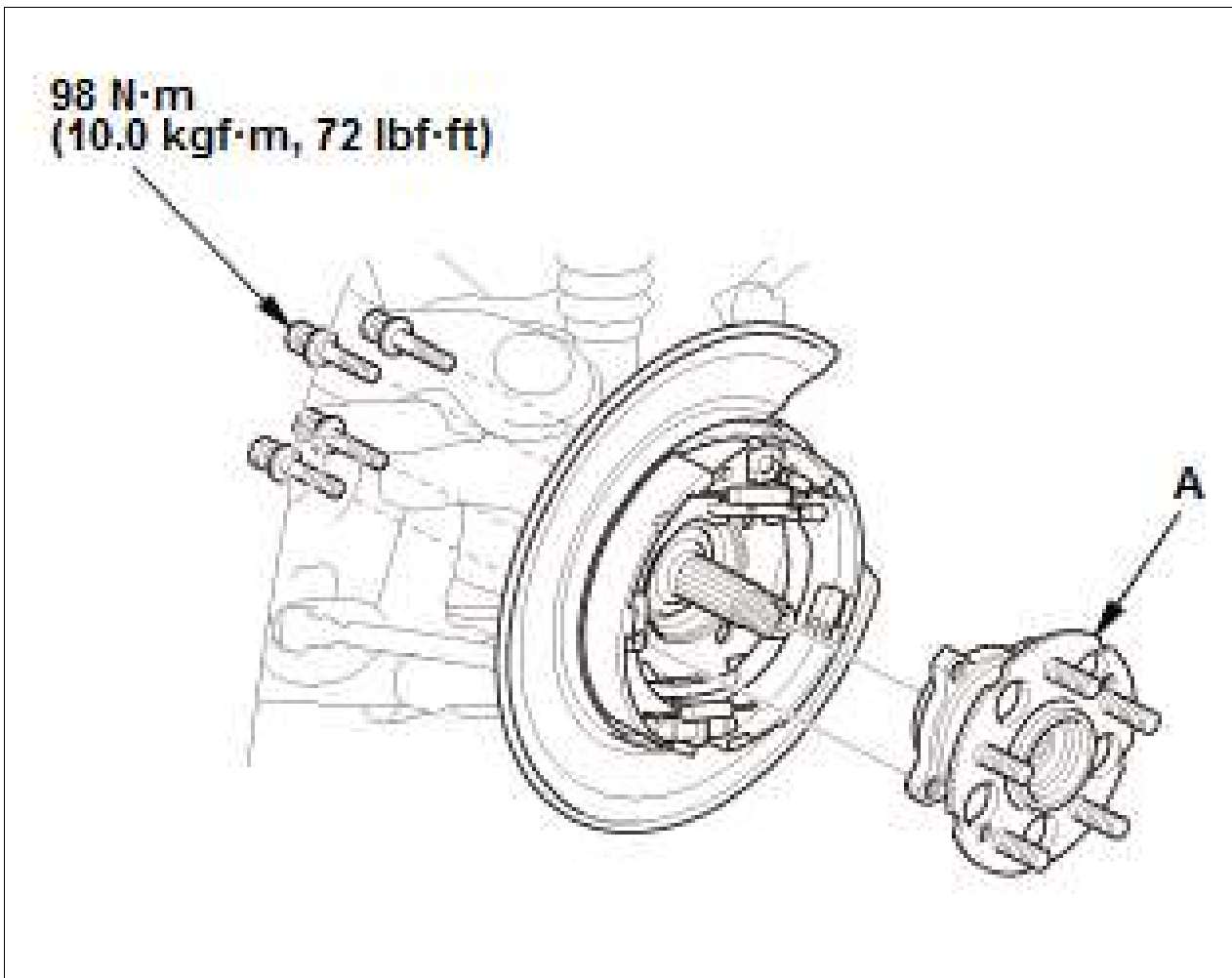

Courtesy of HONDA, U.S.A., INC.

1. Install the hub bearing unit (A).

 **NOTE:** *Keep the wheel bearing/encoder away from any magnetic field. The encoder can be damaged or erased.*

7. Rear Brake Disc/Drum - Install

1. Install the brake disc/drum .

8. Spindle Nut - Install (AWD)

Fig 8: Spindle Nut With Torque Specifications

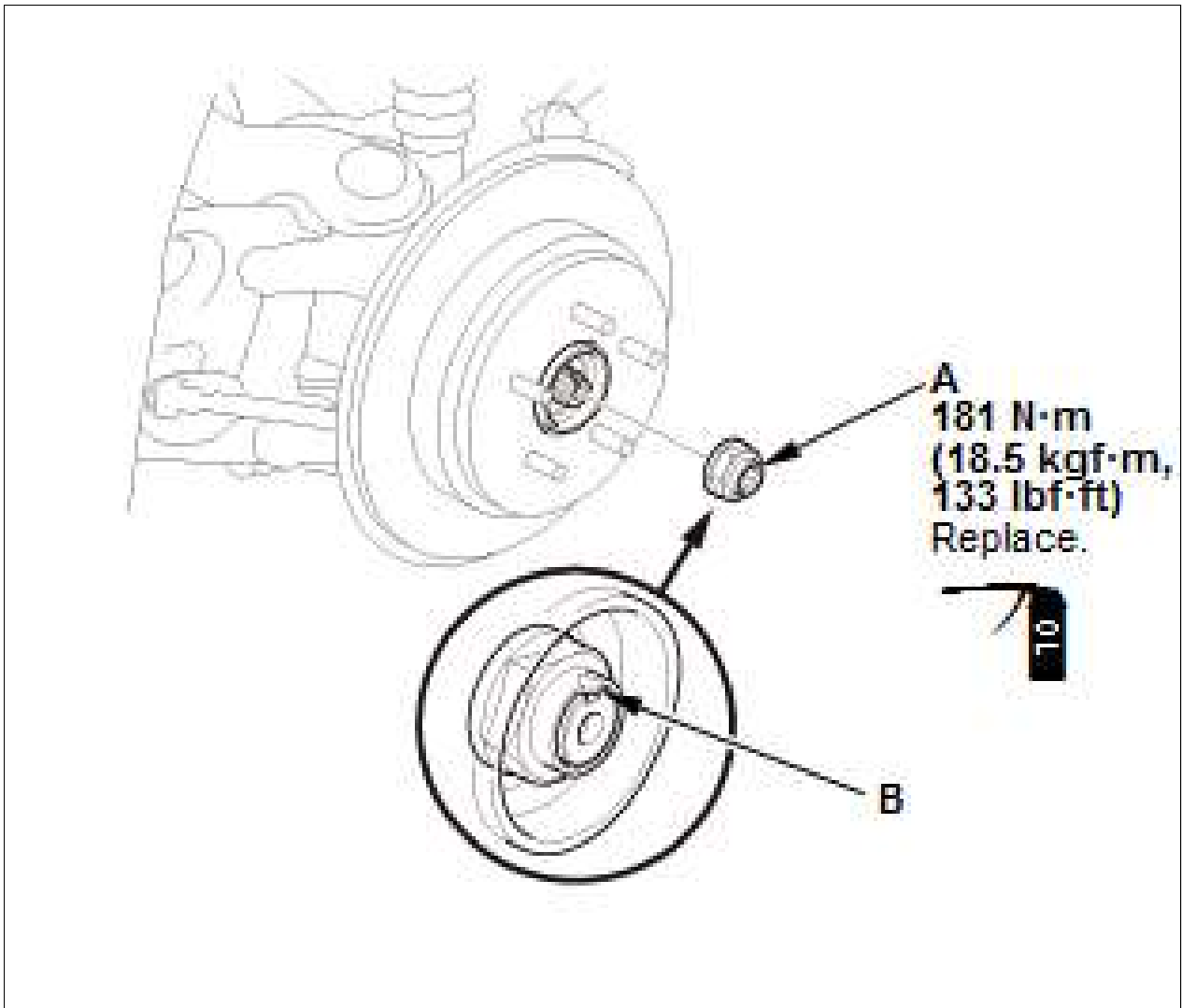

Courtesy of HONDA, U.S.A., INC.

1. AWD: Apply a small amount of engine oil to the seating surface of a new spindle nut (A)
 2. AWD: Install the new spindle nut
 3. AWD: Use a drift to stake the spindle nut shoulder (B) against the driveshaft.
9. Rear Brake Caliper - Install

Fig 9: Rear Brake Caliper With Torque Specifications

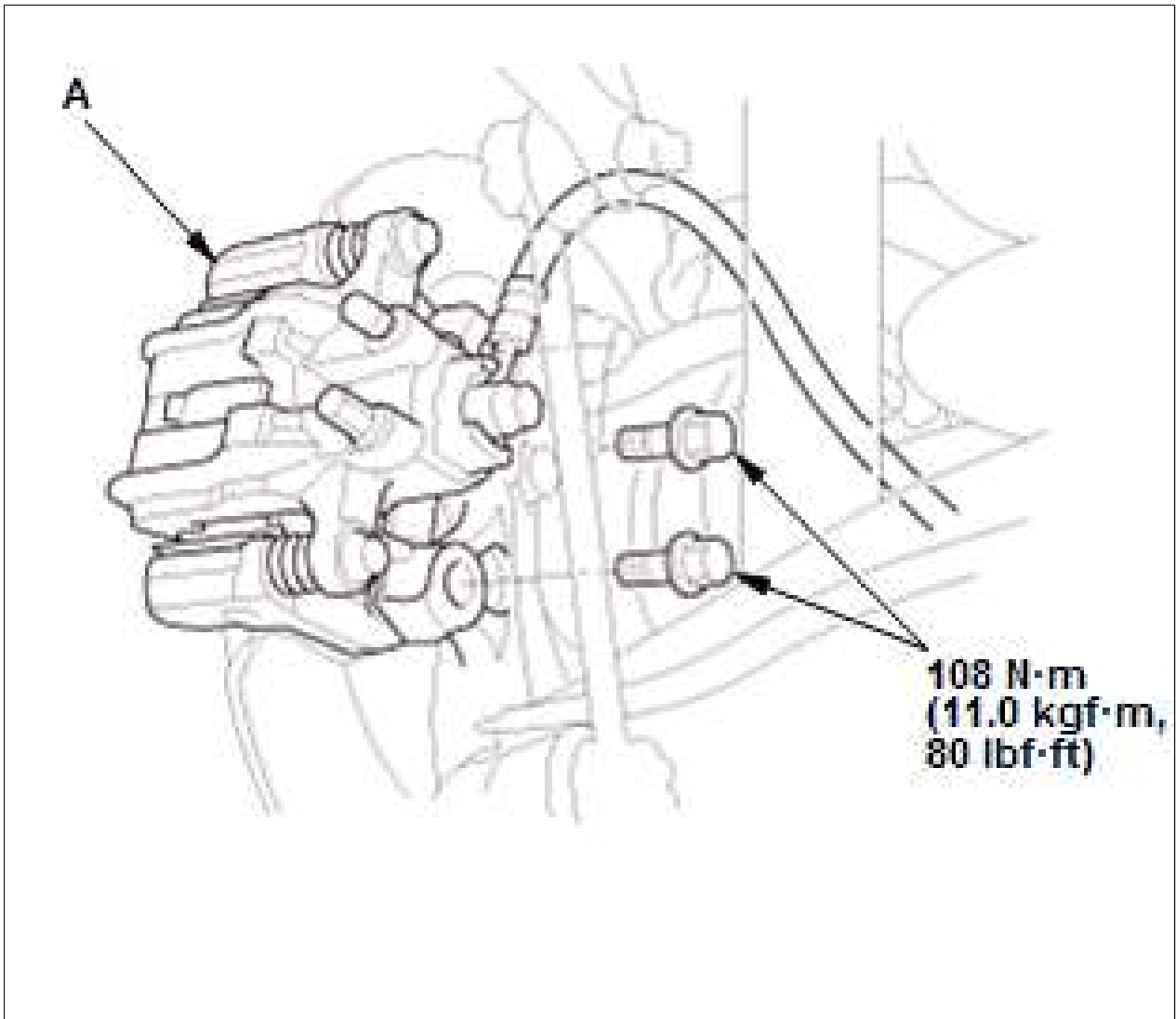

Courtesy of HONDA, U.S.A., INC.

1. Install the caliper assembly (A).

10. Rear Wheel - Install

1. Install the rear wheel .

11. Wheel Alignment - Check

1. Check the wheel alignment, and adjust it if necessary .
--

REMOVAL / INSTALLATION > REAR KNUCKLE/HUB BEARING UNIT REMOVAL AND INSTALLATION (2016-18)

Special Tools Required

Image	Description/Tool Number
-------	-------------------------

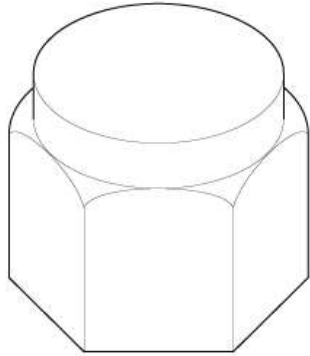

Ball Joint Thread Protector, 12 mm
07AAF-SDAA100

Courtesy of HONDA, U.S.A., INC.



Ball Joint Remover, 32 mm 07MAC-
SL00102

Courtesy of HONDA, U.S.A., INC.

**REMOVAL / INSTALLATION > REAR KNUCKLE/HUB BEARING UNIT REMOVAL AND
INSTALLATION (2016-18) > EXPLODED / VIEW**

Fig 1: Exploded View Of Rear Knuckle/Hub Bearing Unit With Torque Specifications

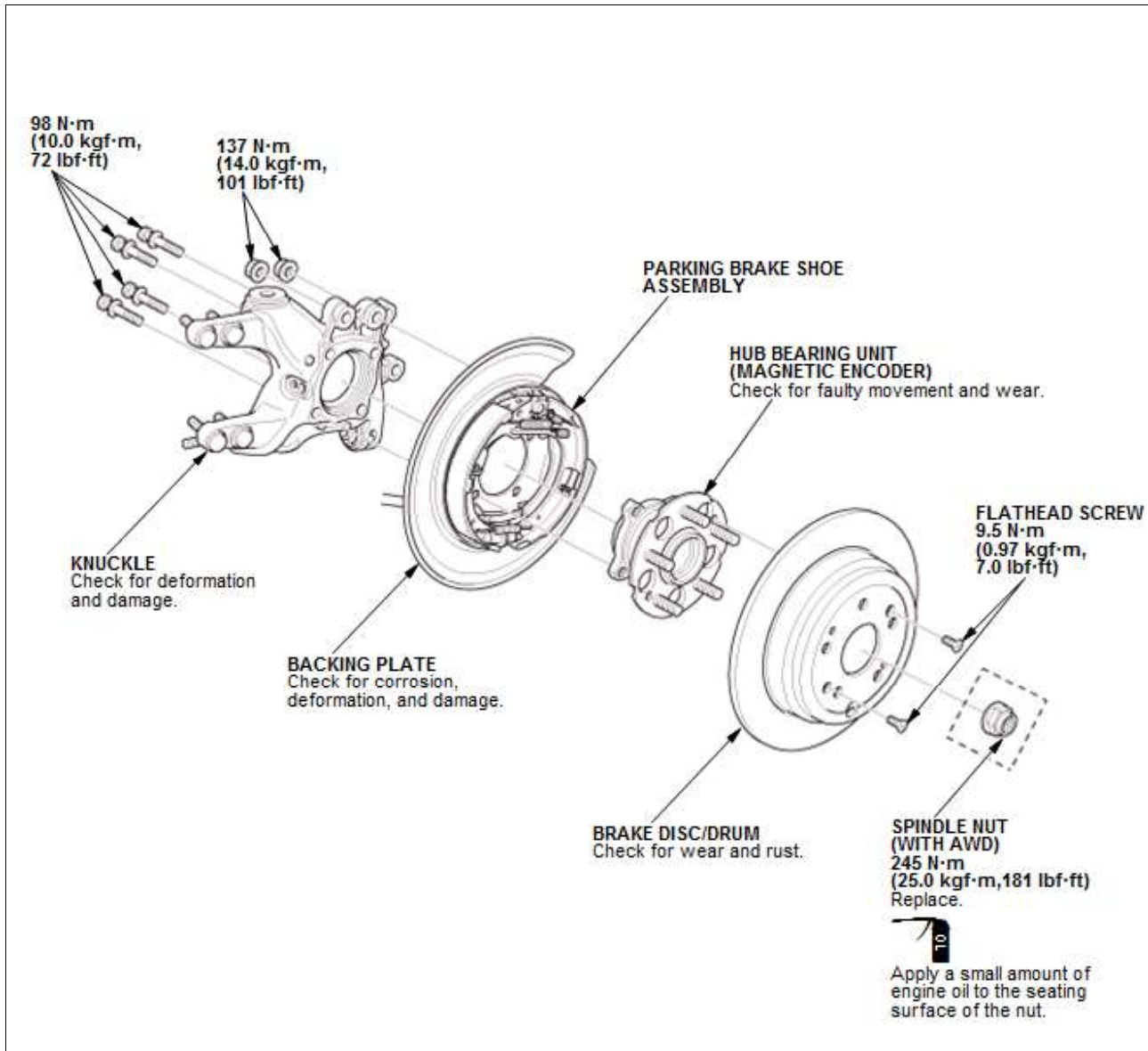

Courtesy of HONDA, U.S.A., INC.

REMOVAL / INSTALLATION > REAR KNUCKLE/HUB BEARING UNIT REMOVAL AND INSTALLATION (2016-18) > REMOVAL / INSTALLATION

NOTE:

- Refer to the Exploded View as needed during the following procedures.
- The illustrations show an AWD model; the 2WD model is similar.

Hub Bearing Unit

1. Vehicle - Lift
2. Rear Wheel - Remove
3. Rear Brake Caliper - Remove

Fig 1: Rear Brake Caliper With Torque Specifications

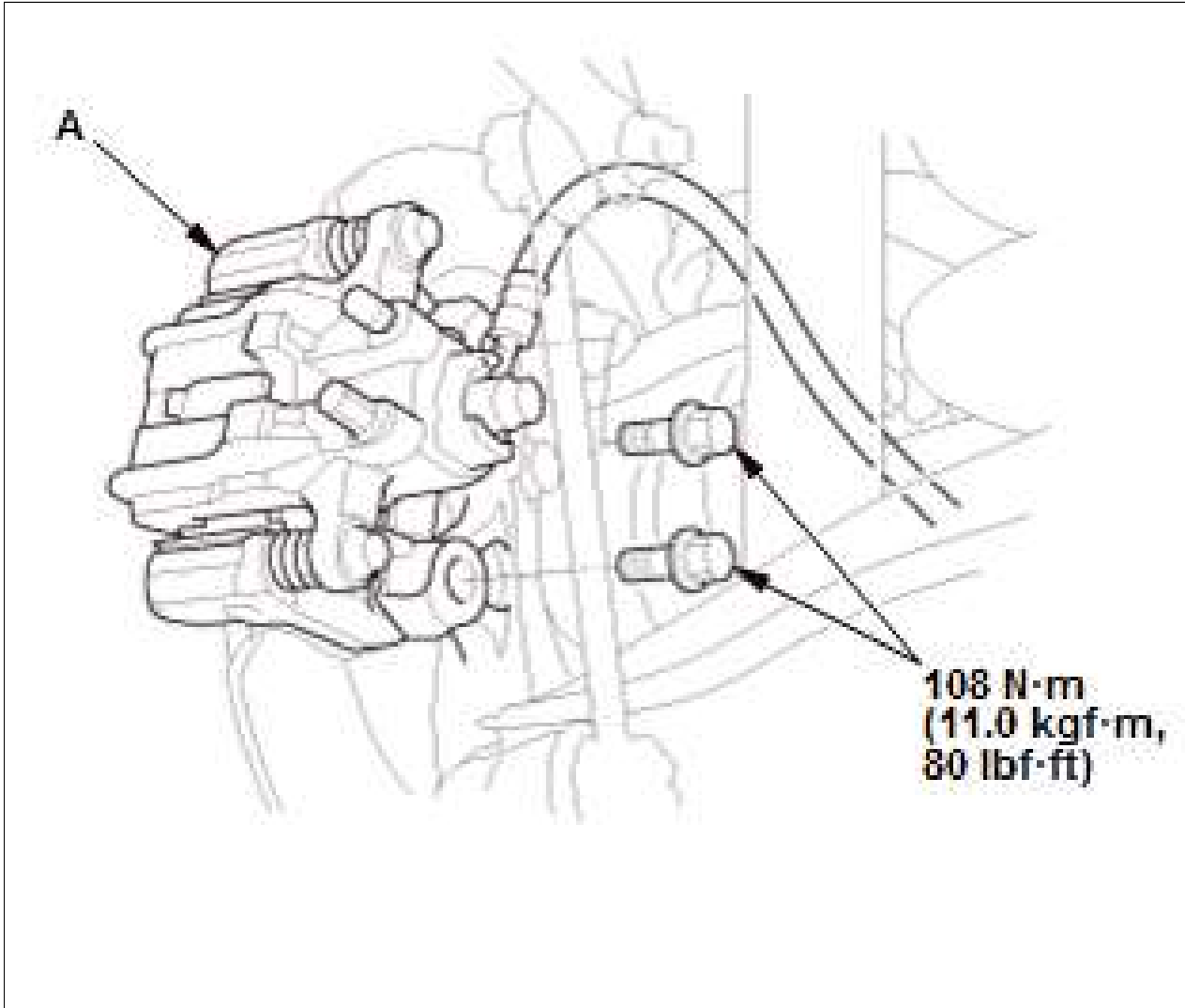

Courtesy of HONDA, U.S.A., INC.

1. Remove the caliper assembly (A).

 **NOTE:**

1. To prevent damage to the caliper assembly or brake hose, use a short piece of wire to hang the caliper assembly from the undercarriage.
2. Do not twist the brake hose excessively.

4. Rear Spindle Nut - Remove (AWD)

Fig 2: Rear Spindle Nut With Torque Specifications

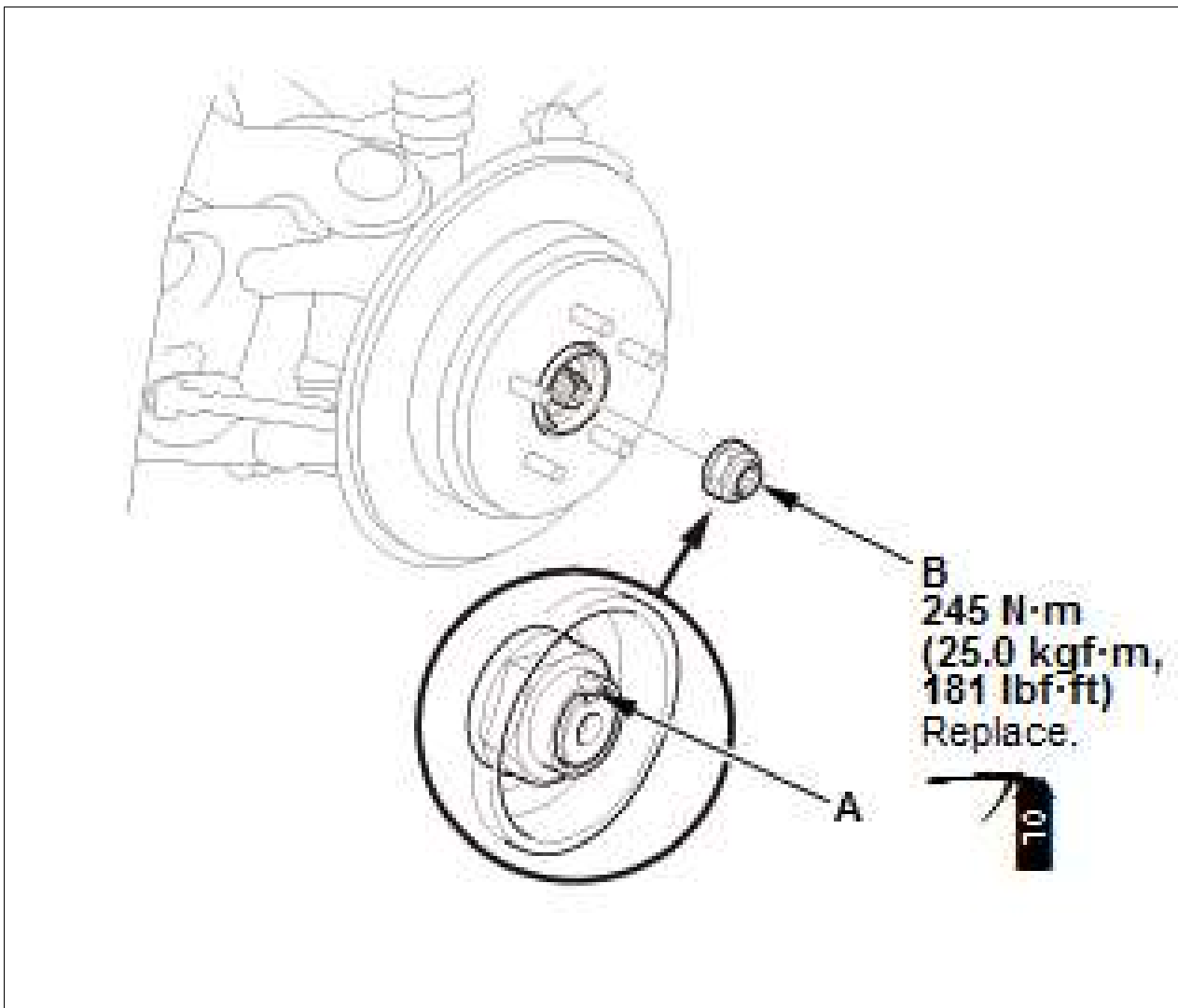

Courtesy of HONDA, U.S.A., INC.

1. Pry up the stake (A) on the spindle nut (B)
2. Remove the spindle nut.



NOTE: Use the new spindle nut during reassembly.

5. Rear Brake Disc/Drum - Remove
6. Hub Bearing Unit - Remove (2WD)

Fig 3: Hub Bearing Unit With Torque Specifications

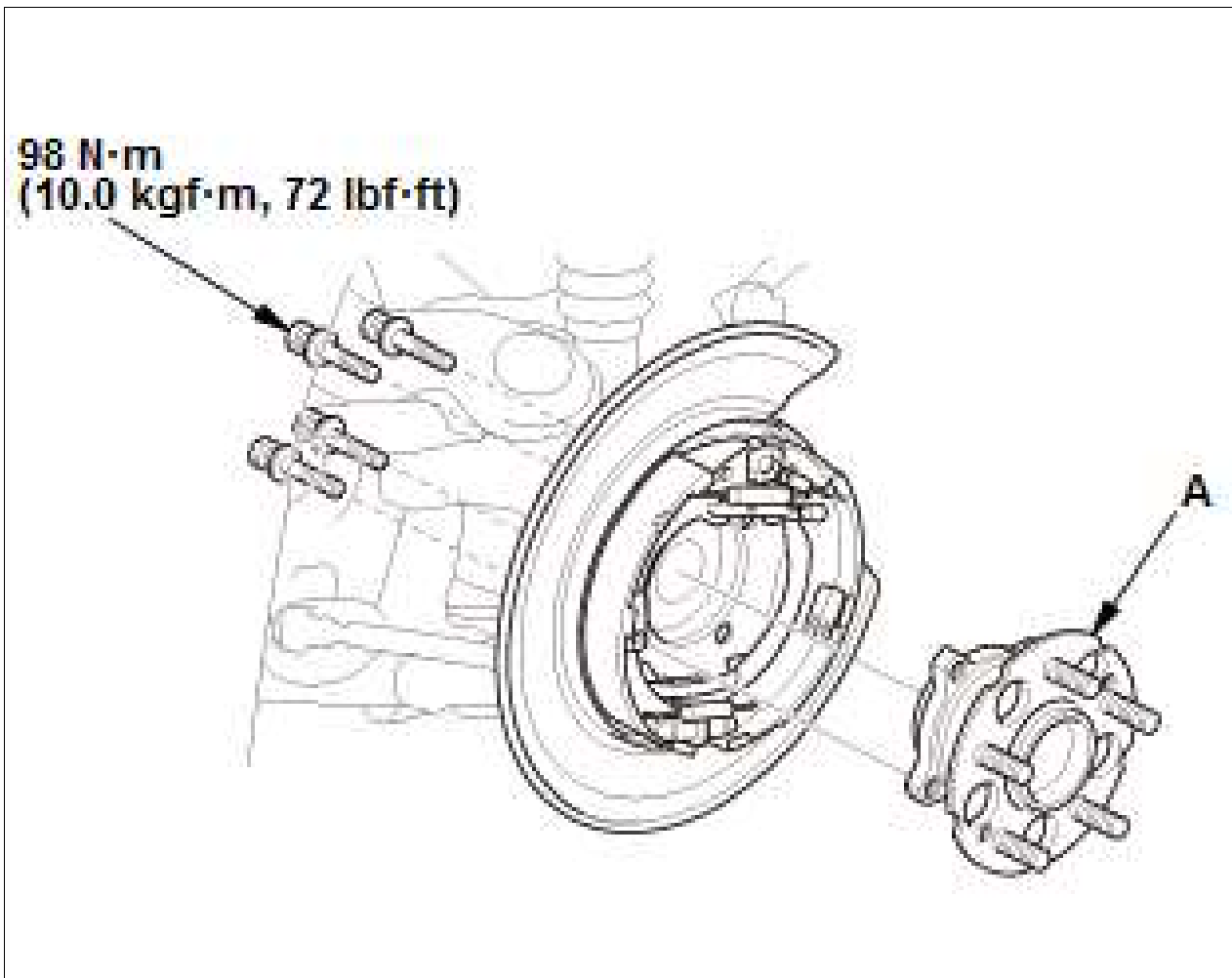

Courtesy of HONDA, U.S.A., INC.

1. Remove the hub bearing unit (A).

 **NOTE:** *Keep the wheel bearing/encoder away from any magnetic field. The encoder can be damaged or erased.*

7. Hub Bearing Unit - Remove (AWD)

Fig 4: Hub Bearing Unit With Torque Specifications

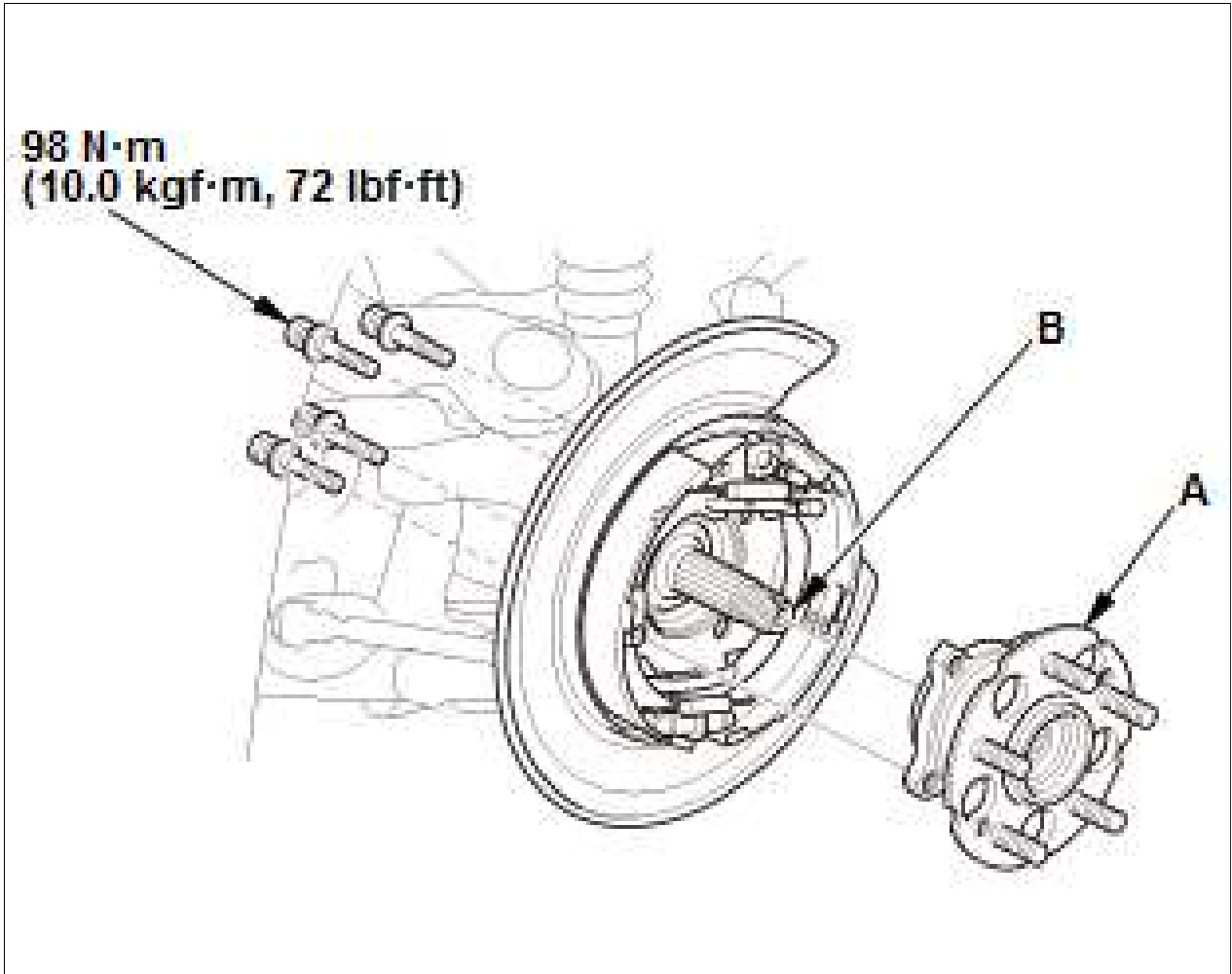

Courtesy of HONDA, U.S.A., INC.

1. Remove the hub bearing unit (A) by tapping the driveshaft end (B) with a soft face hammer while drawing the hub bearing unit outward.

 **NOTE:** Keep the wheel bearing/encoder away from any magnetic field. The encoder can be damaged or erased.

8. Hub Bearing Unit for Damage and Cracks - Check

9. All Removed Parts - Install

1. Install the all removed parts in the reverse order of removal, and note these items:

 **NOTE:** Before installing the spindle nut, apply a small amount of engine oil to the seating surface of the nut. After tightening, use a drift to stake the spindle nut shoulder against the driveshaft.

10. Wheel Alignment - Check
Knuckle

11. Backing Plate - Remove

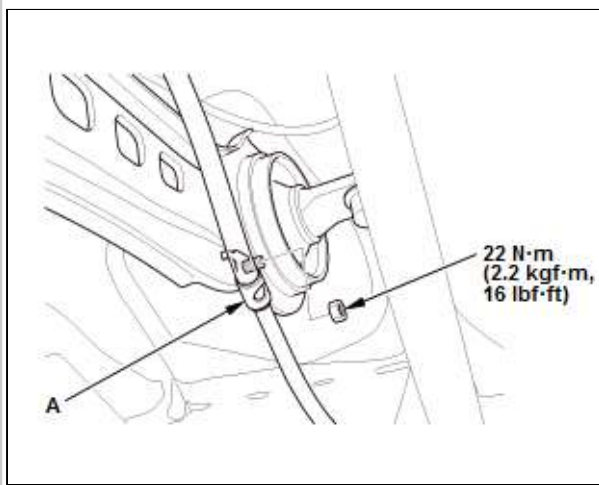

1. Remove the parking brake cable mounting bracket (A).

Courtesy of HONDA, U.S.A., INC.

Fig 5: Backing Plate With Torque Specifications

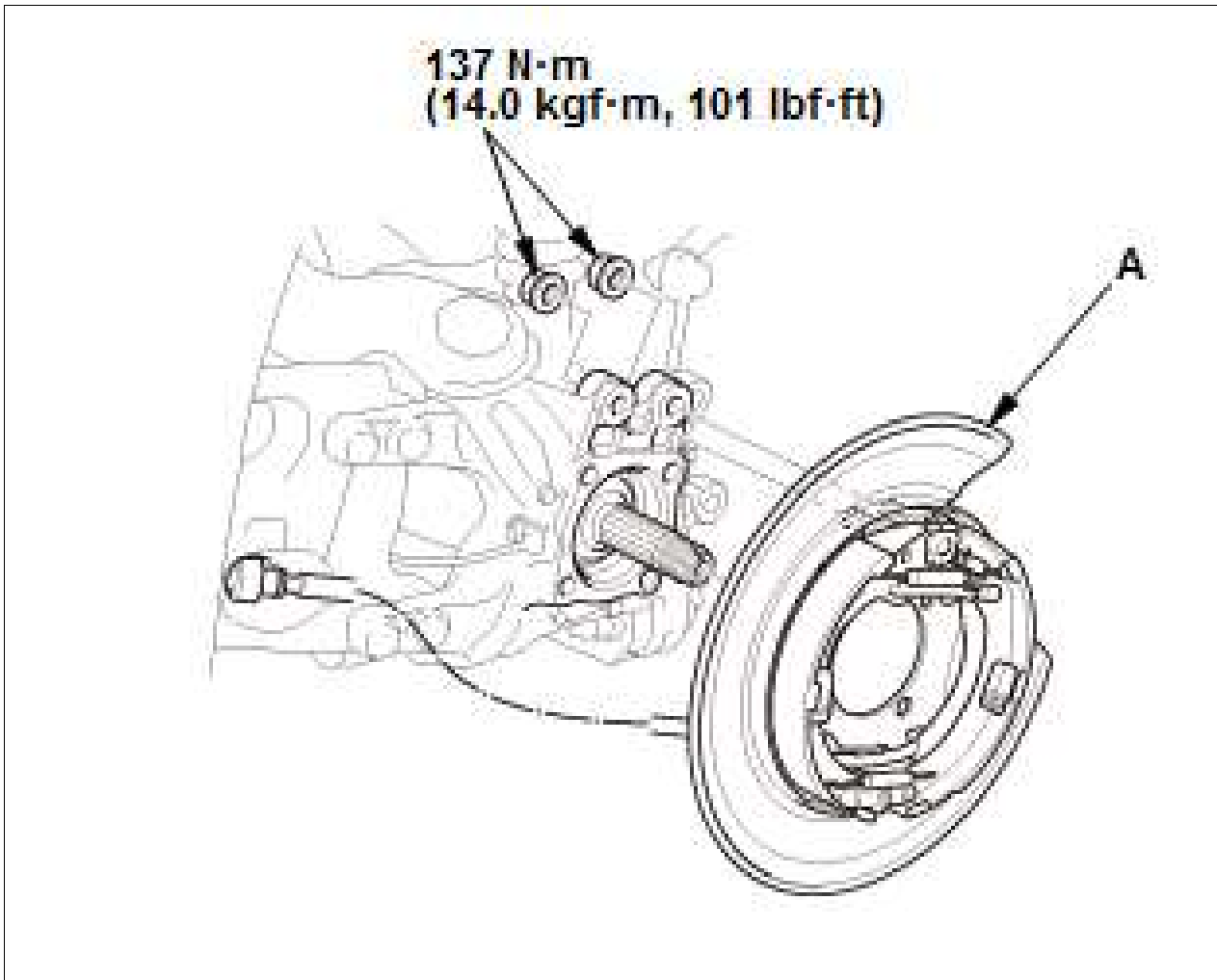

Courtesy of HONDA, U.S.A., INC.

2. Remove the backing plate (A).

 **NOTE:**

1. To prevent damage to the backing plate or parking brake cable, use a short piece of wire to hang the backing plate from the undercarriage.
2. Do not twist the parking brake cable excessively.

12. Rear Wheel Speed Sensor - Remove

1. Remove the wheel speed sensor (A).

 **NOTE:** Do not disconnect the wheel speed sensor connector.

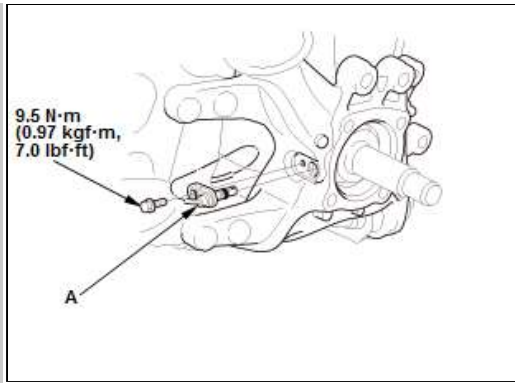

Courtesy of HONDA, U.S.A., INC.

13. Upper Arm Ball Joint - Disconnect

Fig 6: Upper Arm Ball Joint With Torque Specifications

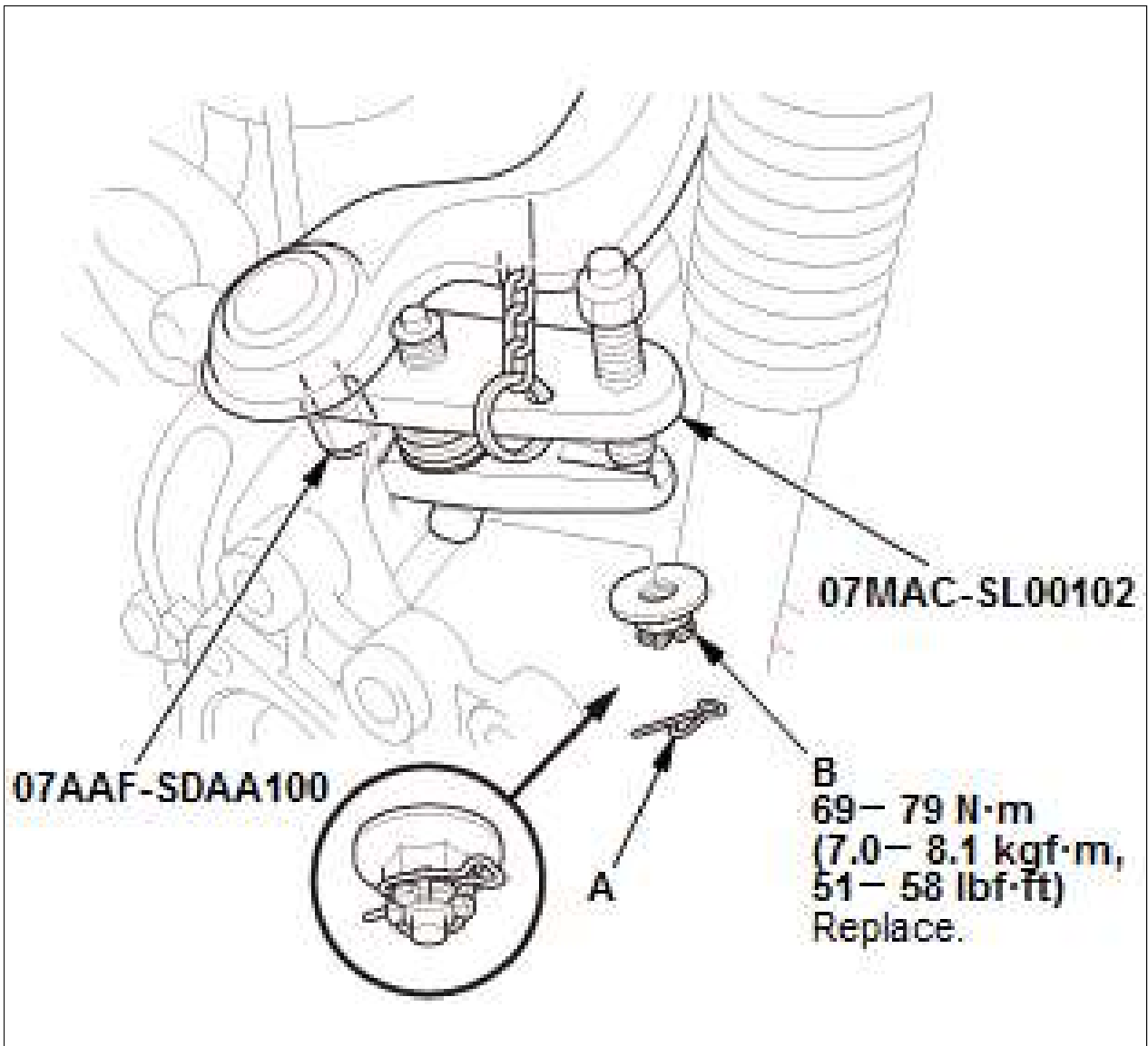

Courtesy of HONDA, U.S.A., INC.

1. Remove the lock pin (A).



NOTE: *During installation, install the lock pin as shown after tightening the new castle nut.*

2. Remove the castle nut (B). Disconnect the upper arm ball joint from the knuckle using the ball joint thread protector and the ball joint remover .



NOTE: *Be careful not to damage the ball joint boot when installing the ball joint remover.*

14. Lower Arm A - Remove

Fig 7: Lower Arm A With Torque Specifications

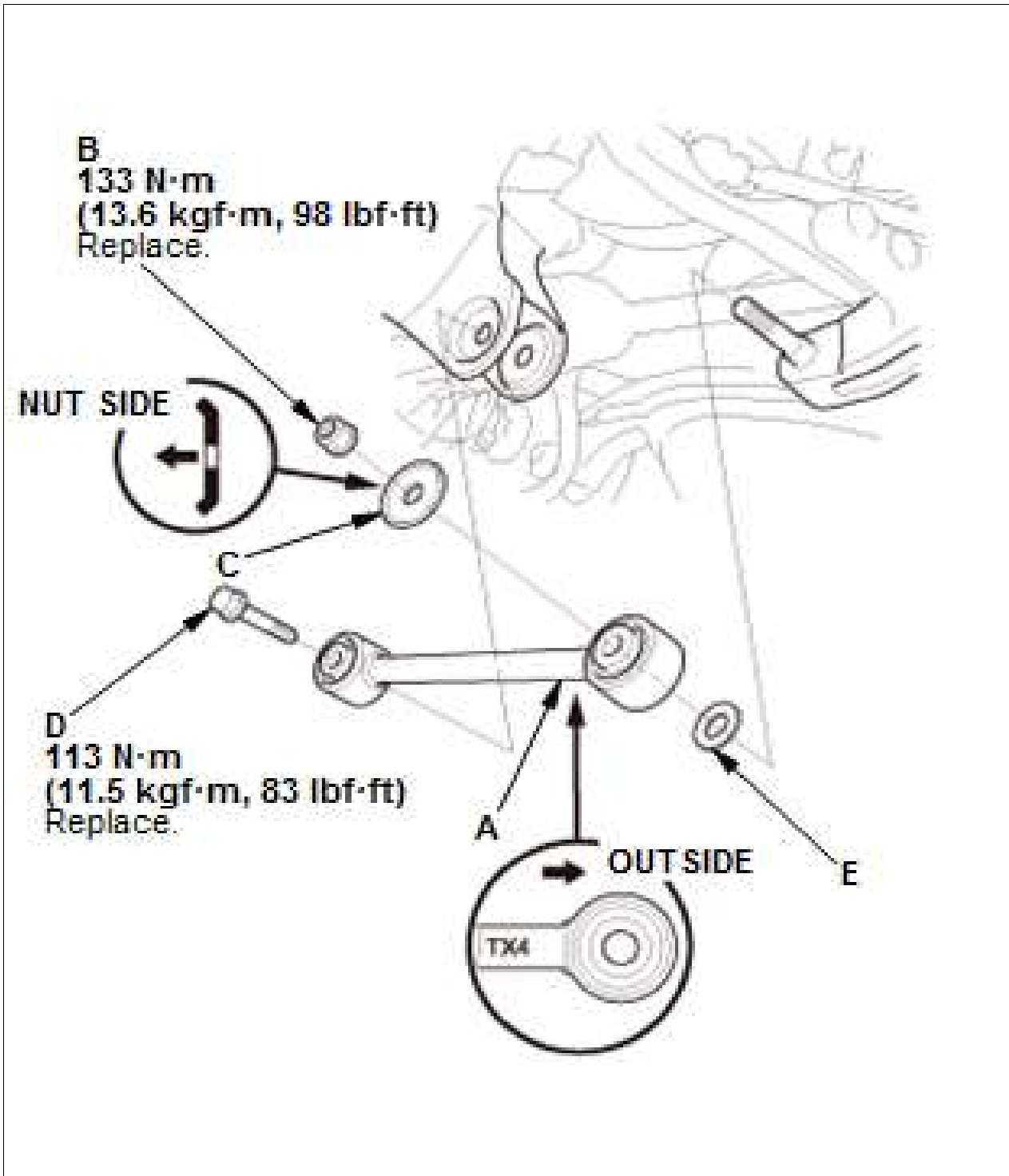

Courtesy of HONDA, U.S.A., INC.

1. Remove the flange nut (B), the washer (C), and the flange bolt (D).

 **NOTE:** Use the new flange nut and the new flange bolt during reassembly

2. Remove the lower arm A
3. Remove the washer (E).

 **NOTE:** Use the new washer during reassembly.

15. Knuckle - Remove

Fig 8: Knuckle Flange Nuts With Torque Specifications

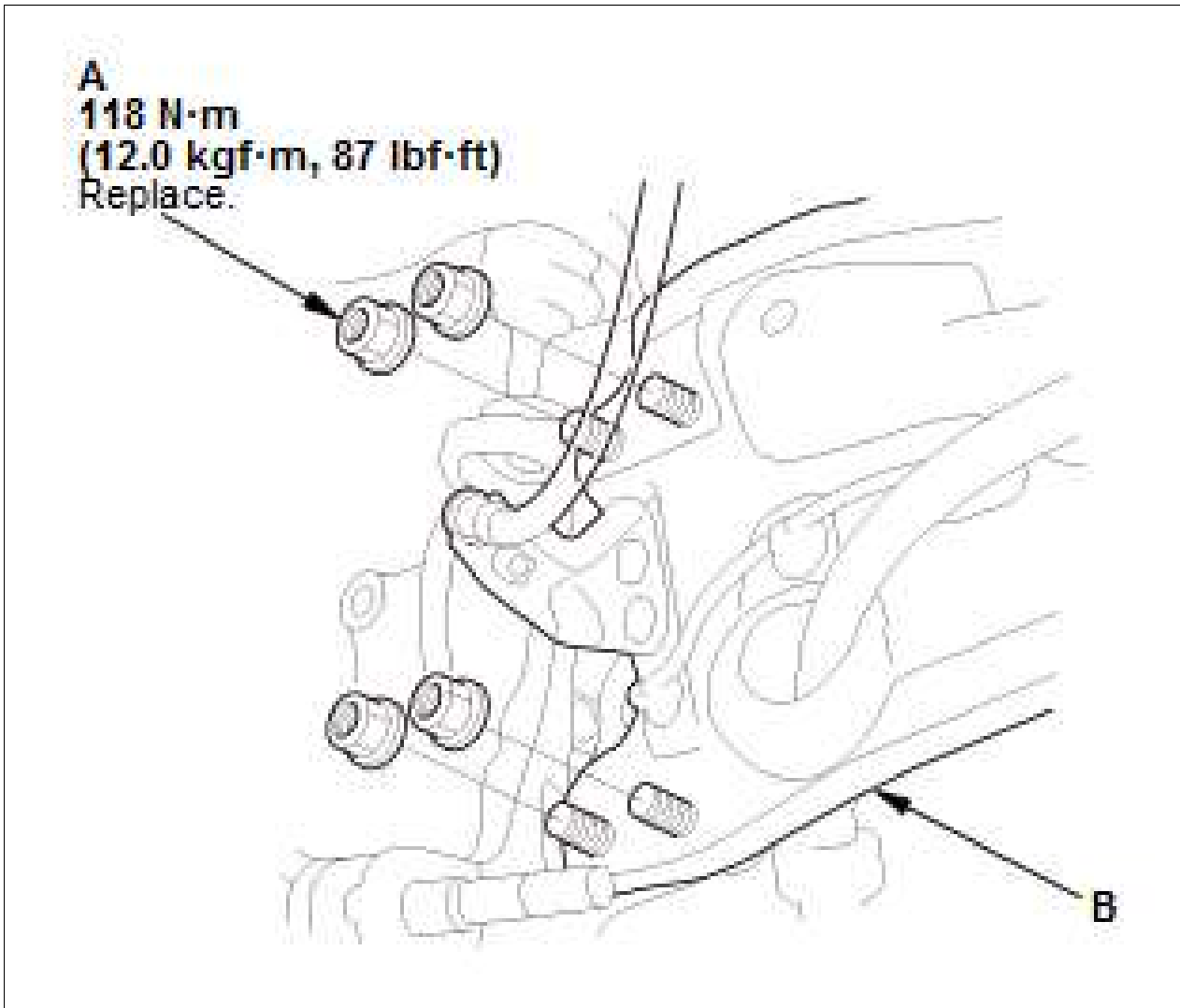

Courtesy of HONDA, U.S.A., INC.

1. Remove the flange nuts (A), and separate the knuckle from the trailing arm (B).

 **NOTE:** Use the new flange nuts during reassembly.

Fig 9: Knuckle Bolt With Torque Specifications

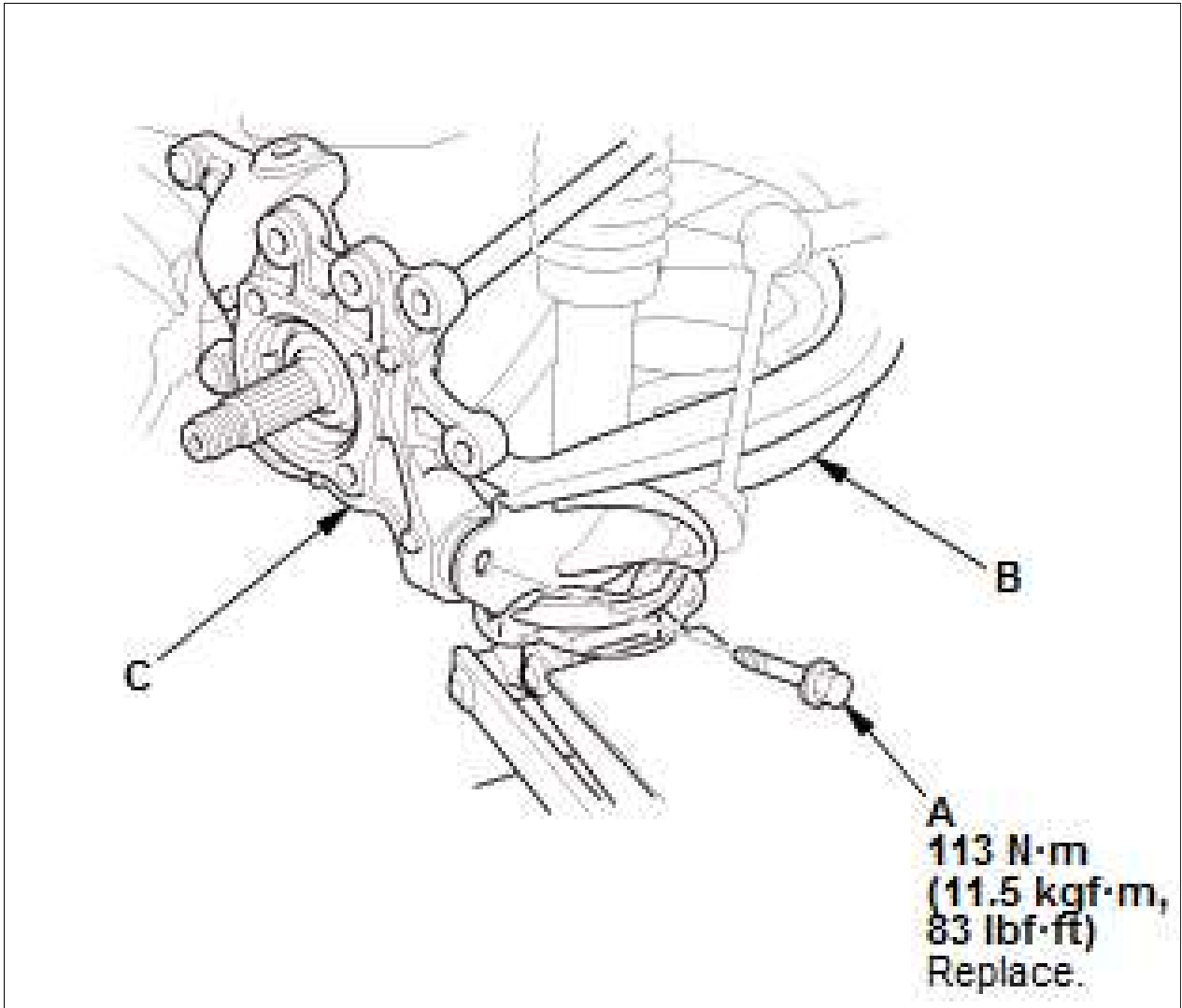

Courtesy of HONDA, U.S.A., INC.

2. Position a floor jack under lower arm B
3. Remove the flange bolt (A).

 **NOTE:** Use the new flange bolt during reassembly

4. Remove the knuckle (C).

16. All Removed Parts - Install

1. Install the all removed parts in the reverse order of removal, and note these items:

 **NOTE:**

1. Loosely install nuts and/or bolts to install the bushings, load the suspension with the vehicle's weight, and then tighten the nuts and/or bolts to the specified torque.

2. Be careful not to damage the ball joint boot when connecting the knuckle.
3. Before connecting the ball joint, degrease the threaded section and the tapered portion of the ball joint pin, the ball joint connecting hole, the threaded section, and the mating surfaces of the castle nut.
4. Torque the castle nut to the lower torque specification, then tighten it only far enough to align the slot with the ball joint pin hole. Do not align the castle nut by loosening it.

17. Wheel Alignment - Check

REMOVAL / INSTALLATION > REAR LOWER ARM A REMOVAL AND INSTALLATION (2013-18) > REMOVAL

1. Vehicle - Lift

1. Raise and support the vehicle .

2. Rear Wheel - Remove

1. Remove the rear wheel .

3. Lower Arm B - Support

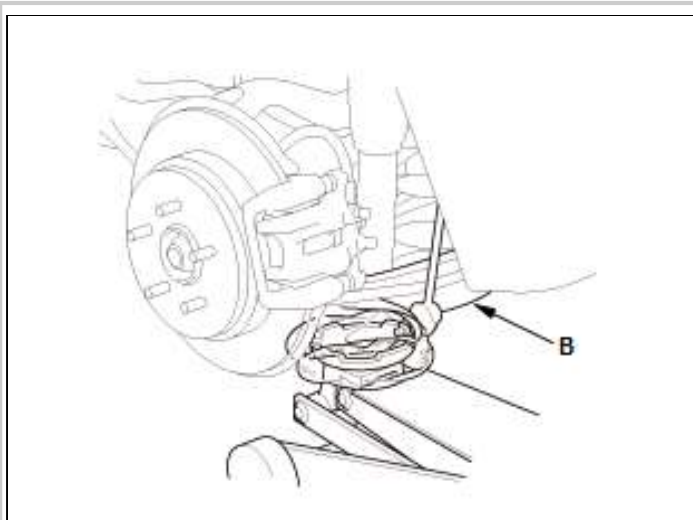

1. Position a floor jack under lower arm B.

Courtesy of HONDA, U.S.A., INC.

4. Lower Arm A - Remove

- | |
|--|
| <ol style="list-style-type: none"> 1. Remove the flange nut (B), the washer (C), and the flange bolt (D) 2. Remove the lower arm A 3. Remove the washer (E) if necessary. |
|--|

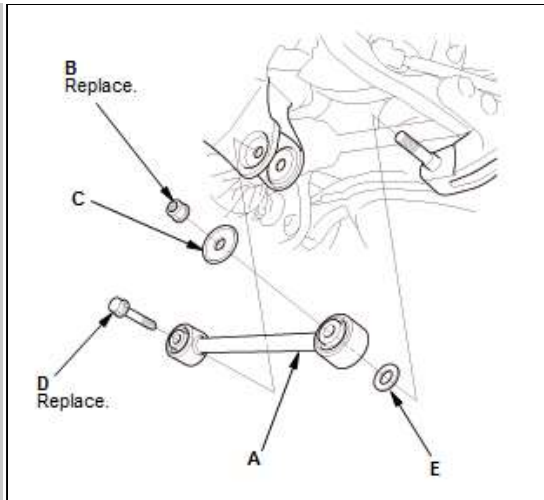

Courtesy of HONDA, U.S.A., INC.

REMOVAL / INSTALLATION > REAR LOWER ARM A REMOVAL AND INSTALLATION (2013-18) > INSTALLATION

 **NOTE:** First install all the components, and lightly tighten the bolts and the nuts, then raise the suspension to load it with the vehicle's weight before fully tightening to the specified torque.

1. Lower Arm A - Install

Fig 1: Lower Arm A With Torque Specifications

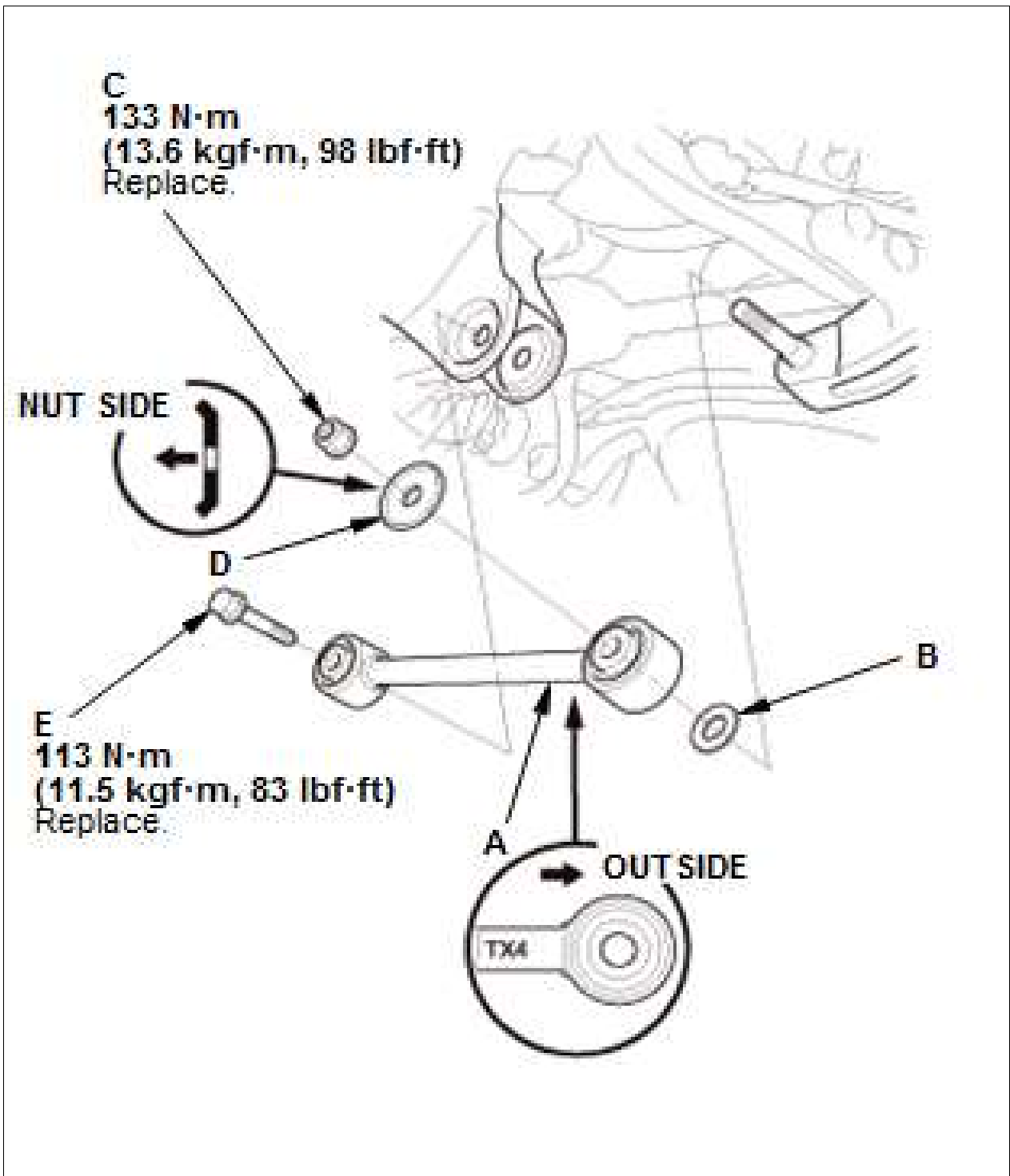

Courtesy of HONDA, U.S.A., INC.

1. Install the washer (B)
 2. Install the lower arm A
 3. Install the new flange nut (C), the washer (D), and the new flange bolt (E).
-
2. Rear Wheel - Install
 1. Install the rear wheel .

3. Wheel Alignment - Check

1. Check the wheel alignment, and adjust it if necessary .

REMOVAL / INSTALLATION > REAR LOWER ARM B REMOVAL AND INSTALLATION (2013-15) > REMOVAL

1. Vehicle - Lift

1. Raise and support the vehicle .

2. Rear Wheel - Remove

1. Remove the rear wheel .

3. Lower Arm B - Support

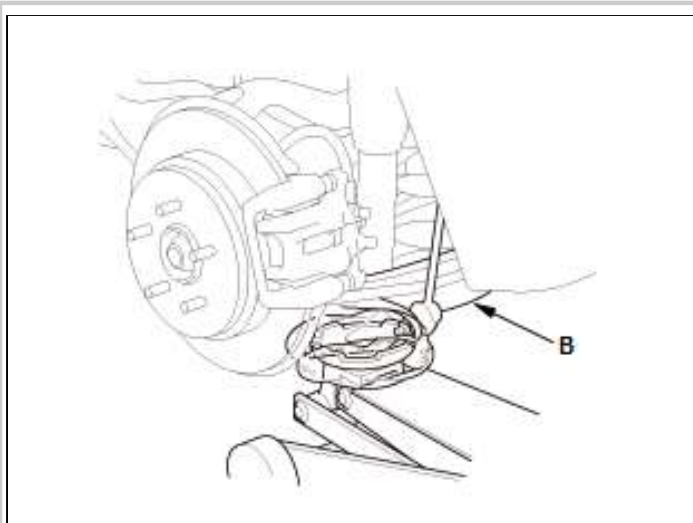

1. Position a floor jack under lower arm B.

Courtesy of HONDA, U.S.A., INC.

4. Lower Arm B - Remove

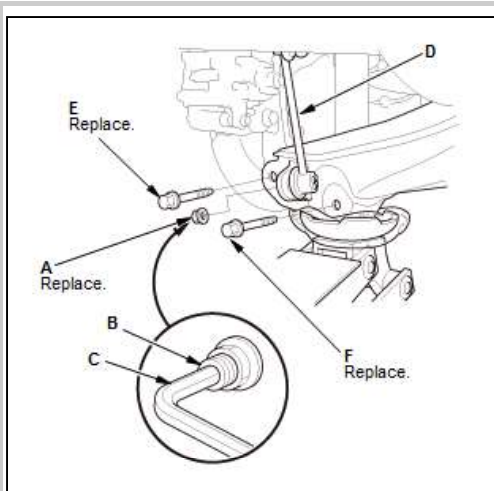

1. Remove the flange nut (A) while holding the joint pin (B) with a hex wrench (C)
2. Disconnect the stabilizer link (D) from the lower arm B
3. Remove the flange bolt (E) that connects lower arm B to the knuckle
4. Remove the flange bolt (F) that connects lower arm B to the damper
5. Lower the floor jack gradually.

Courtesy of HONDA, U.S.A., INC.

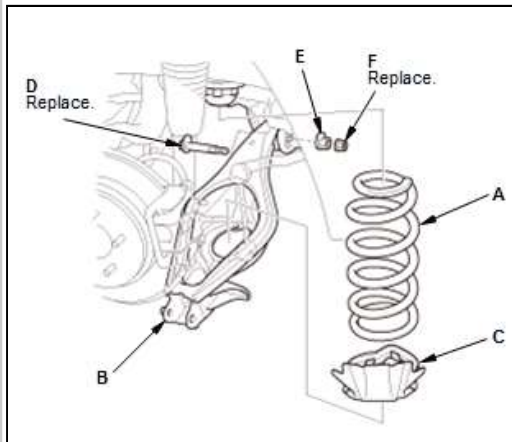

Courtesy of HONDA, U.S.A., INC.

6. Remove the spring (A)
7. Remove the lower spring cushion (C)
8. Mark the cam positions of the adjusting bolt (D) and the adjusting cam (E)
9. Remove the self-locking nut (F), the adjusting cam, and the adjusting bolt
10. Remove the lower arm B.

REMOVAL / INSTALLATION > REAR LOWER ARM B REMOVAL AND INSTALLATION (2013-15) > INSTALLATION

 **NOTE:** First install all the components, and lightly tighten the bolts and the nuts, then raise the suspension to load it with the vehicle's weight before fully tightening to the specified torque.

1. Lower Arm B - Install

Fig 1: Lower Arm B With Torque Specifications

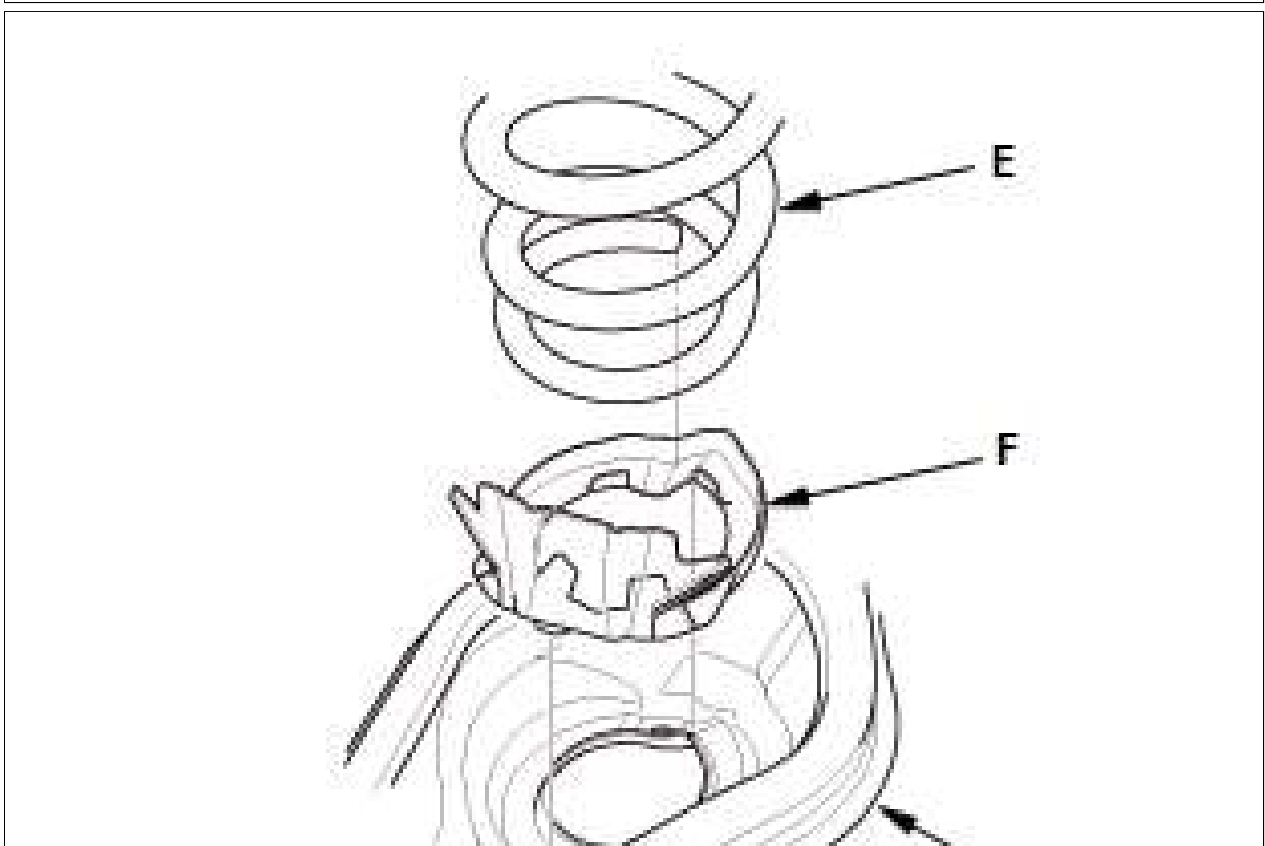
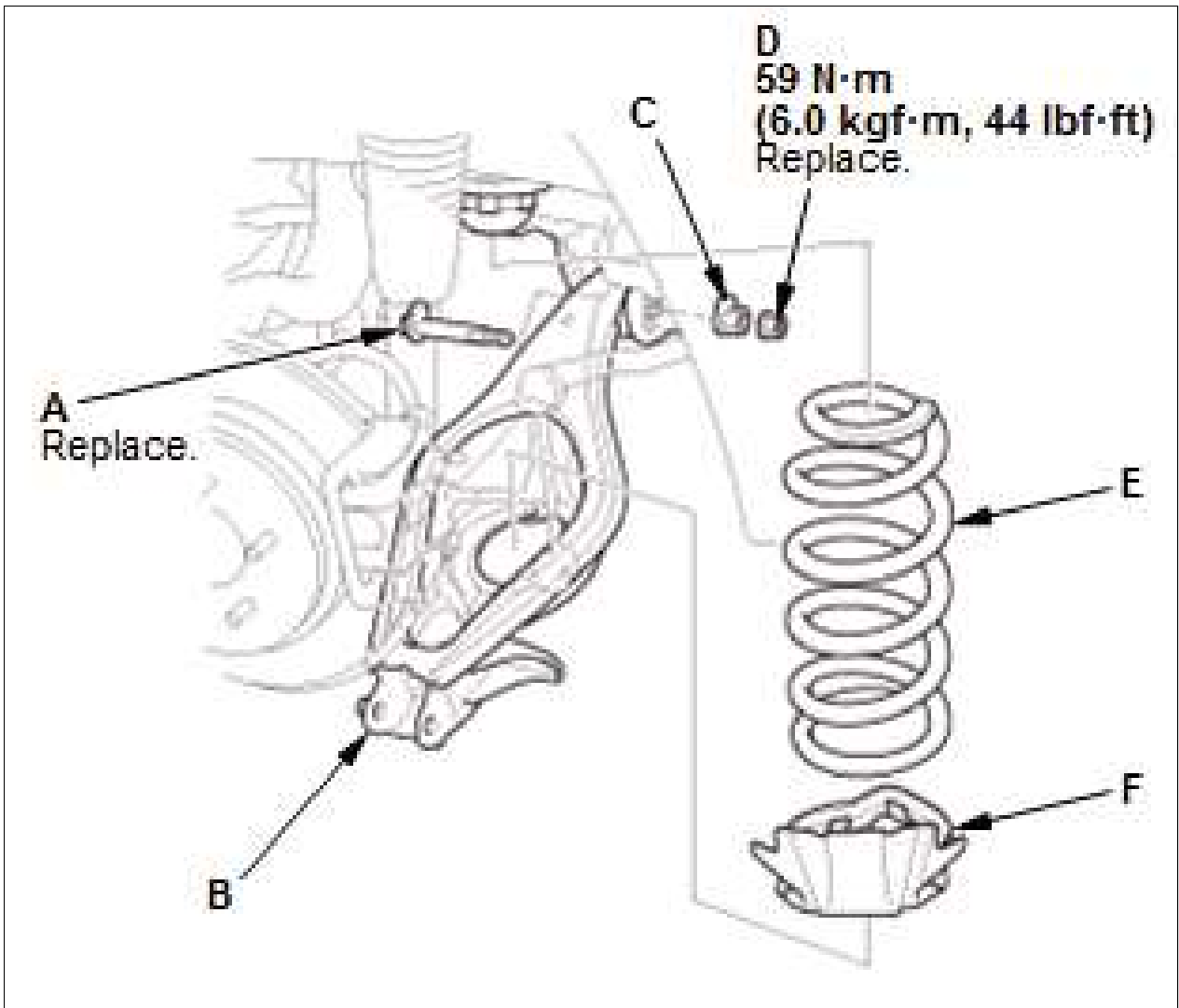



Courtesy of HONDA, U.S.A., INC.HONDA, U.S.A., INC.

	<ol style="list-style-type: none">1. Position lower arm B2. Install a new adjusting bolt (A), the adjusting cam (C), and a new self-locking nut (D)3. Install the spring (E) and the lower spring cushion (F). Align the bottom of the spring and the lower spring cushion with lower arm B as shown.
--	---

Courtesy of HONDA, U.S.A., INC.

Fig 2: Lower Arm B Bolts With Torque Specifications

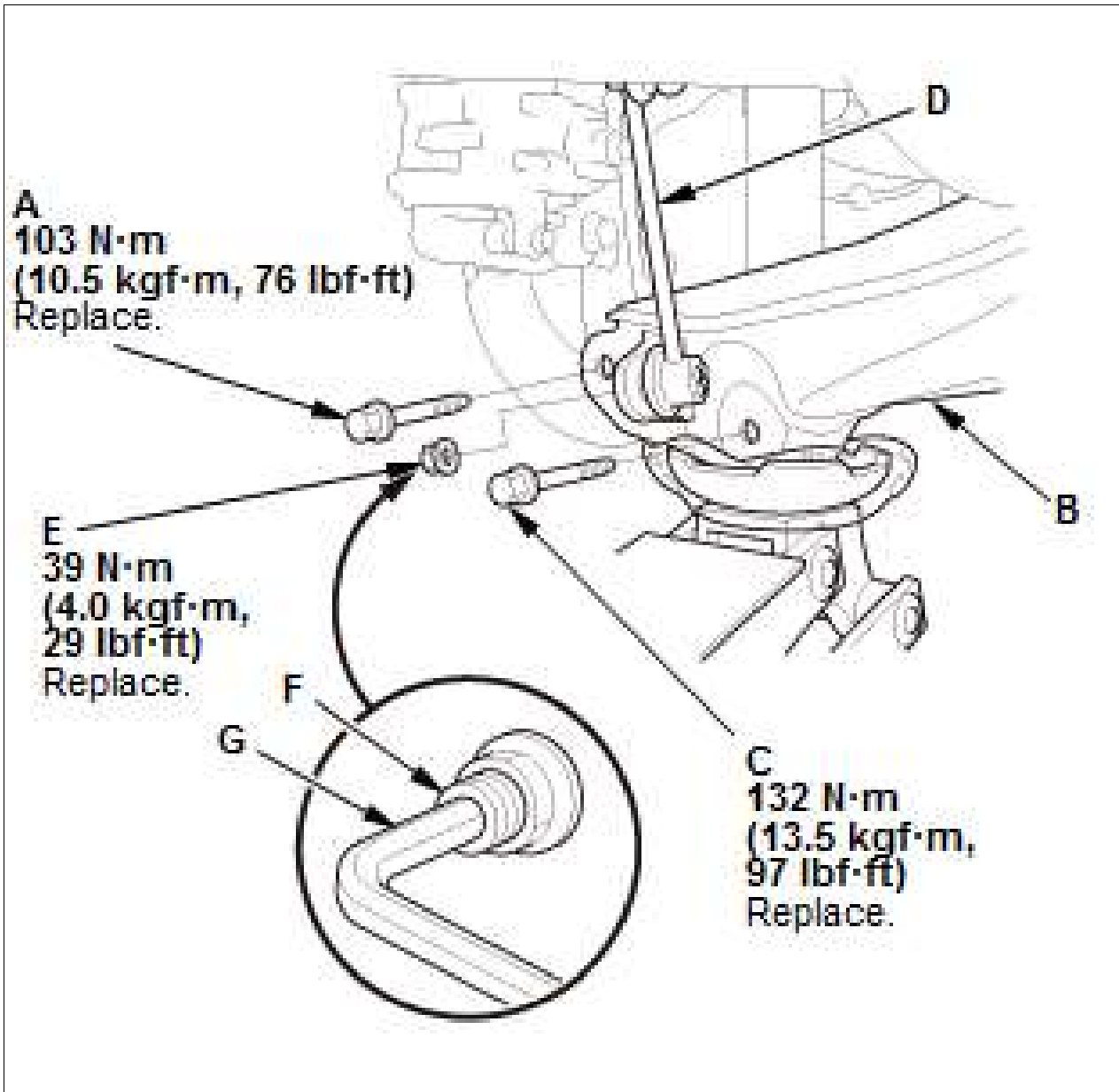

Courtesy of HONDA, U.S.A., INC.

4. Position a floor jack under lower arm B
 5. Slowly raise the floor jack until you align the bolt hole with the holes in lower arm B and the knuckle
 6. Install the new flange bolt (A)
 7. Compress the damper by hand until you align the bolt hole with the holes in lower arm B and the damper
 8. Install the new flange bolt (C)
 9. Connect the stabilizer link (D) to lower arm B
 10. Tighten the new flange nut (E) while holding the joint pin (F) with a hex wrench (G).
2. Rear Wheel - Install
 1. Install the rear wheel .
 3. Wheel Alignment - Check
 1. Check the wheel alignment, and adjust it if necessary .

REMOVAL / INSTALLATION > REAR LOWER ARM B REMOVAL AND INSTALLATION (2016-18) > REMOVAL

1. Vehicle - Lift
2. Rear Wheel - Remove
3. Lower Arm B - Support

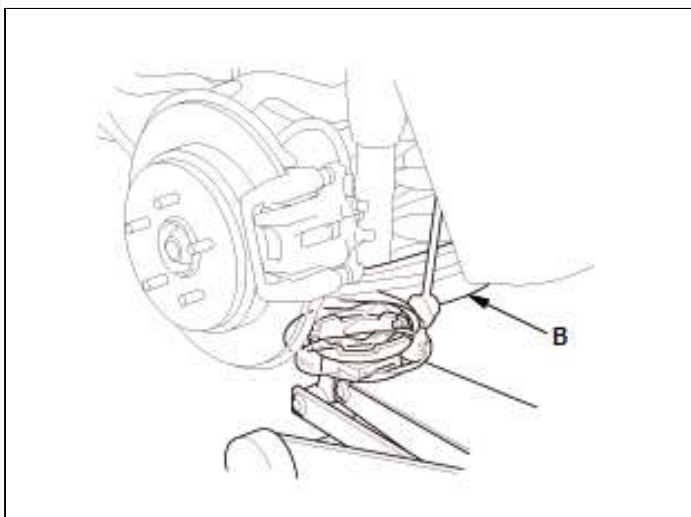

1. Position a floor jack under lower arm B.

Courtesy of HONDA, U.S.A., INC.

4. Lower Arm B - Remove

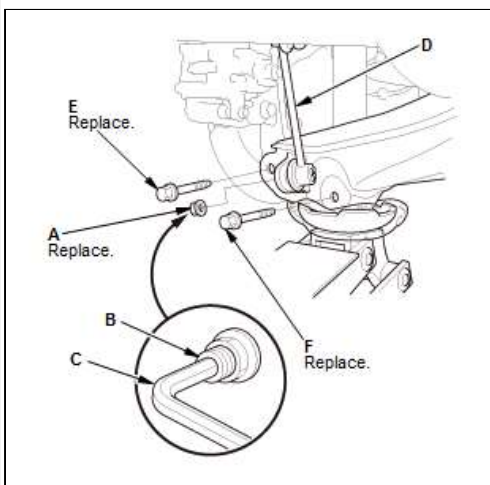

1. Remove the flange nut (A) while holding the joint pin (B) with a hex wrench (C)
2. Disconnect the stabilizer link (D) from lower arm B
3. Remove the flange bolt (E) that connects lower arm B to the knuckle
4. Remove the flange bolt (F) that connects lower arm B to the damper
5. Lower the floor jack gradually.

Courtesy of HONDA, U.S.A., INC.

6. Remove the spring (A)
7. Remove the lower spring cushion (C)
8. Mark the cam positions of the adjusting bolt (D) and the adjusting cam (E)

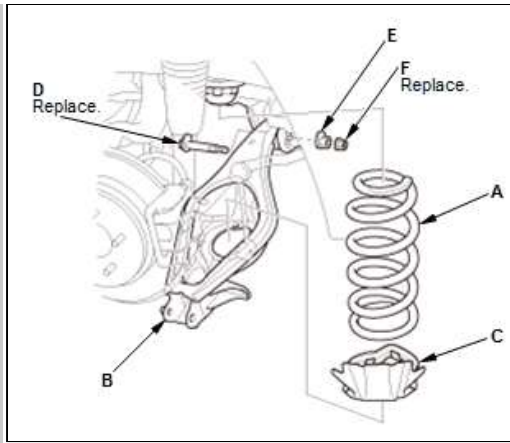

Courtesy of HONDA, U.S.A., INC.

9. Remove the self-locking nut (F), the adjusting cam, and the adjusting bolt
10. Remove the lower arm B.

REMOVAL / INSTALLATION > REAR LOWER ARM B REMOVAL AND INSTALLATION (2016-18) > INSTALLATION

 **NOTE:** Loosely install nuts and/or bolts to install the bushings, load the suspension with the vehicle's weight, and then tighten the nuts and/or bolts to the specified torque.

1. Lower Arm B - Install

Fig 1: Lower Arm B With Torque Specifications

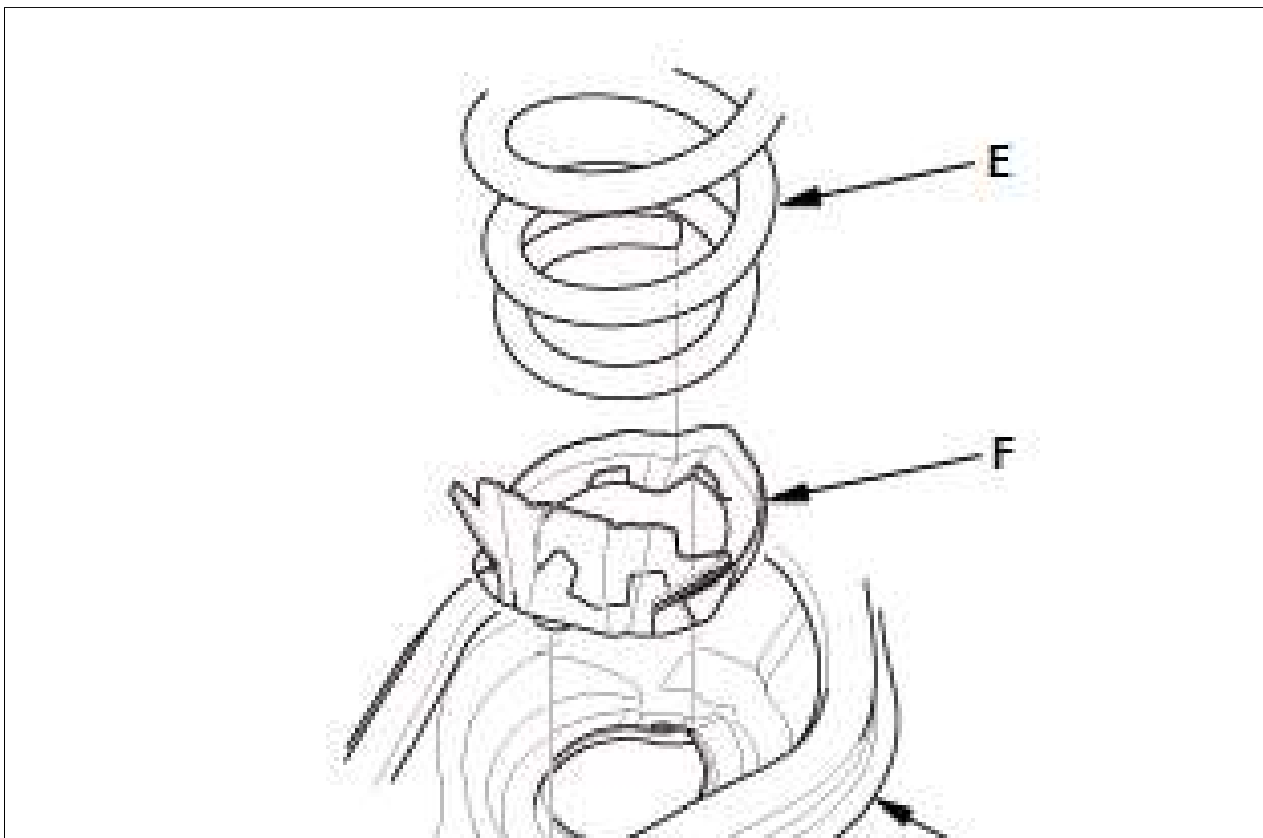
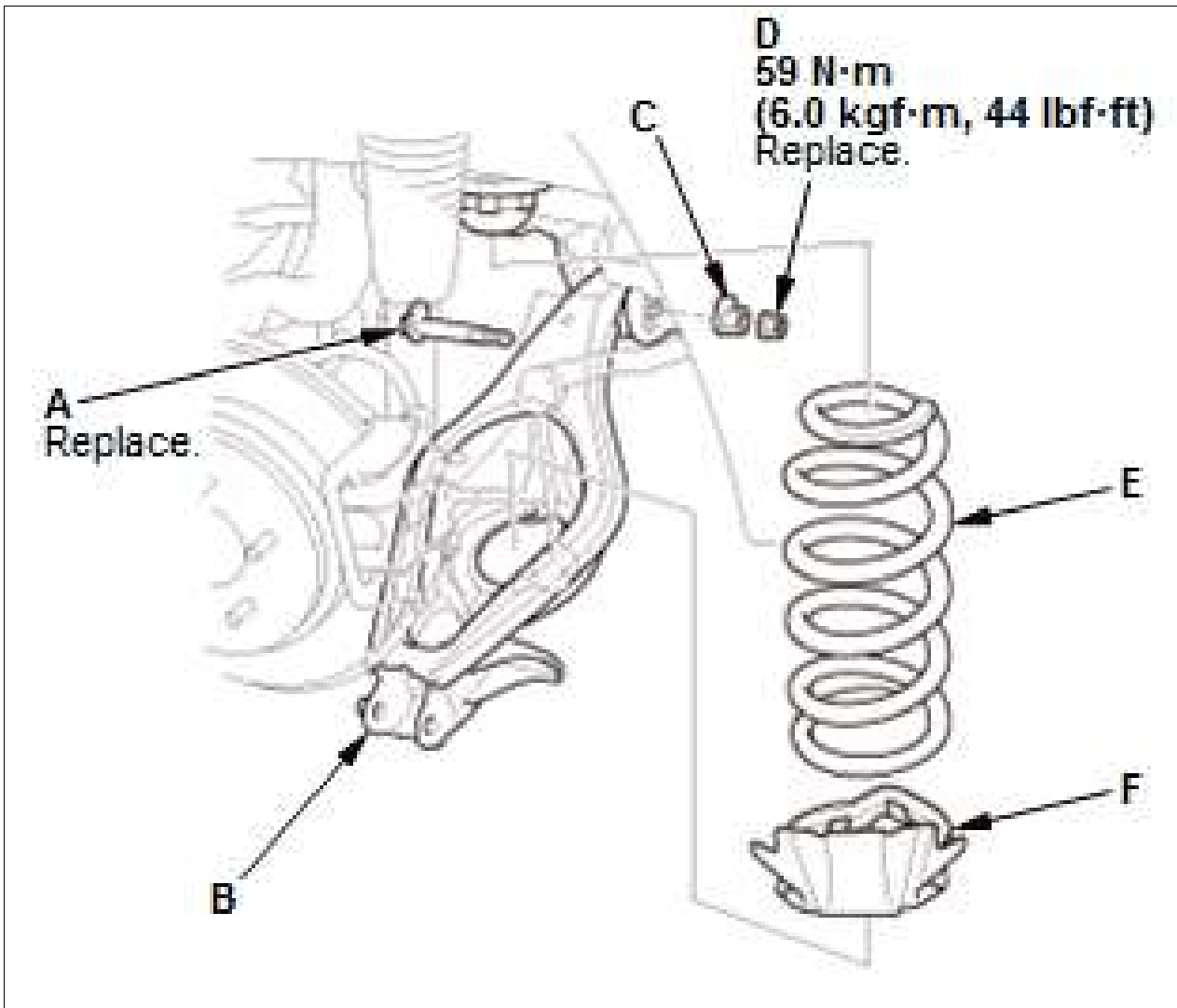



Courtesy of HONDA, U.S.A., INC.HONDA, U.S.A., INC.

	<ol style="list-style-type: none">1. Position lower arm B2. Install the new adjusting bolt (A), the adjusting cam (C), and the new self-locking nut (D)3. Install the spring (E) and the lower spring cushion (F). Align the bottom of the spring and the lower spring cushion with lower arm B as shown.
--	---

Courtesy of HONDA, U.S.A., INC.

Fig 2: Lower Arm B Bolts With Torque Specifications

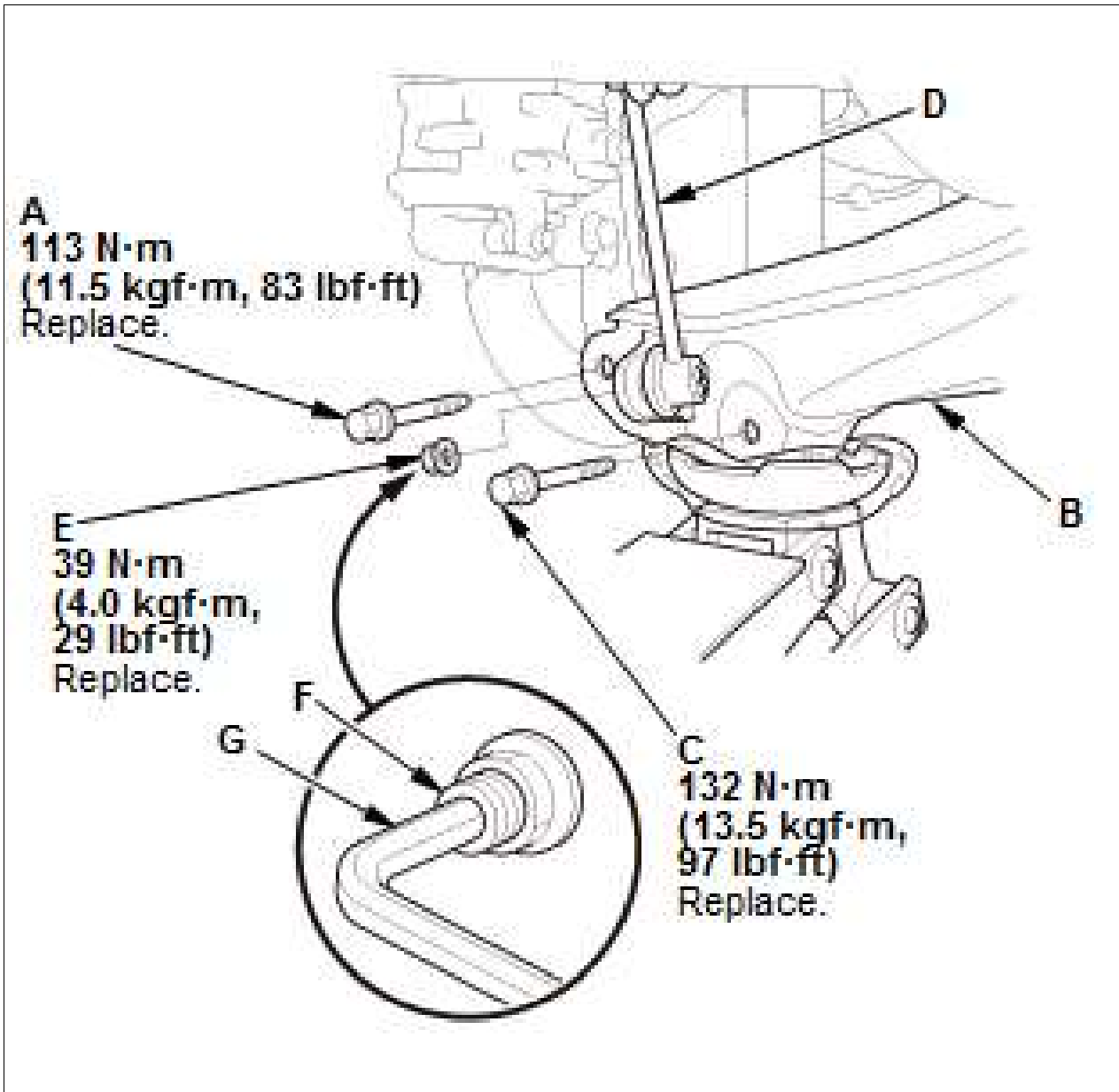

Courtesy of HONDA, U.S.A., INC.

4. Position a floor jack under lower arm B
 5. Slowly raise the floor jack until you align the bolt hole with the holes in lower arm B and the knuckle
 6. Install the new flange bolt (A)
 7. Compress the damper by hand until you align the bolt hole with the holes in lower arm B and the damper
 8. Install the new flange bolt (C)
 9. Connect the stabilizer link (D) to lower arm B
 10. Tighten the new flange nut (E) while holding the joint pin (F) with a hex wrench (G).
2. Rear Wheel - Install
 1. Install the rear wheel .
 3. Wheel Alignment - Check
 1. Check the wheel alignment, and adjust it if necessary .

REMOVAL / INSTALLATION > REAR SPRING REMOVAL AND INSTALLATION (2013-15) > EXPLODED / VIEW

Fig 1: Exploded View Of Rear Spring

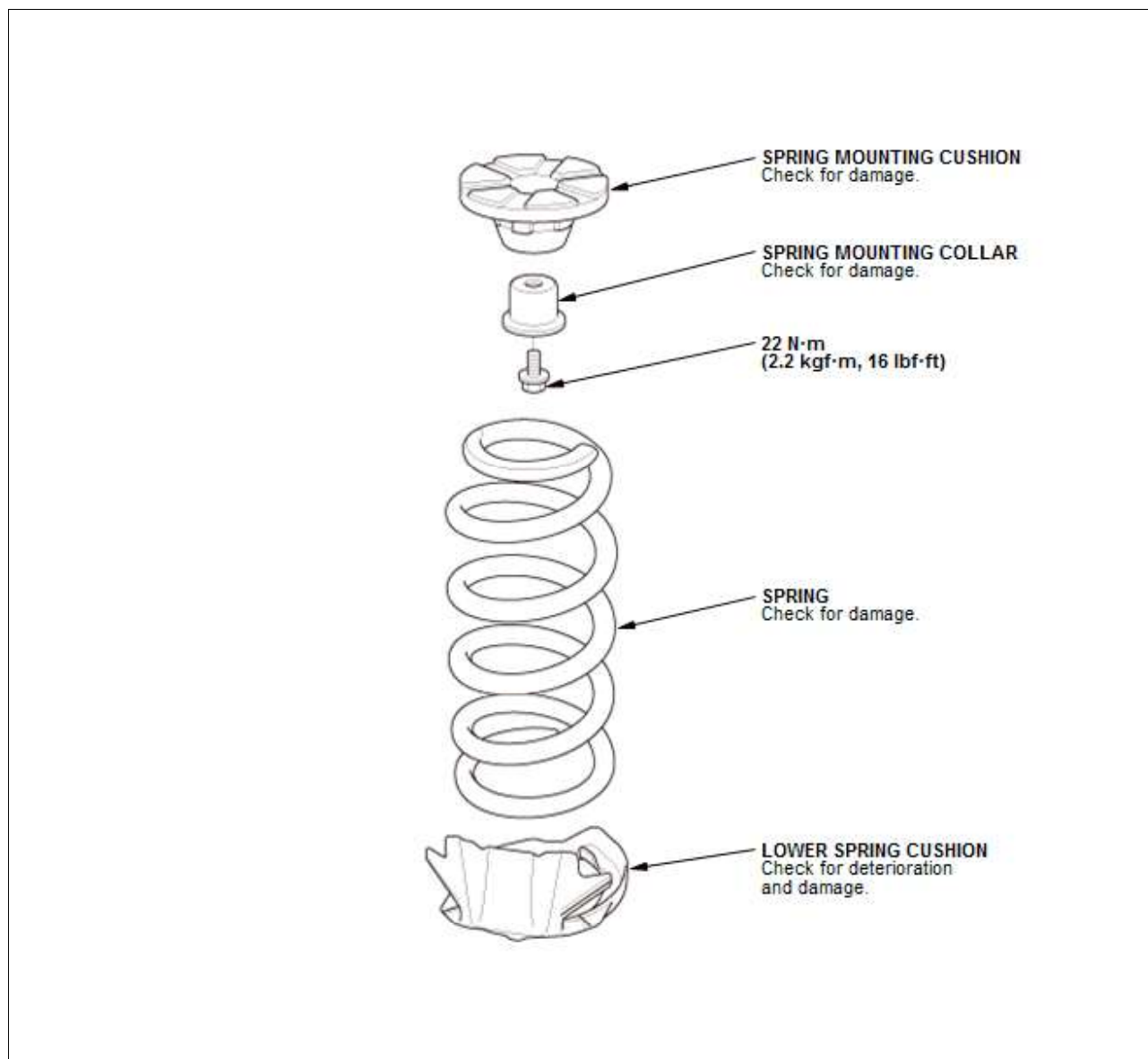

Courtesy of HONDA, U.S.A., INC.

REMOVAL / INSTALLATION > REAR SPRING REMOVAL AND INSTALLATION (2013-15) > REMOVAL

 **NOTE:** Refer to the Exploded View as needed during the following procedures.

1. Vehicle - Lift

1. Raise and support the vehicle .

2. Rear Wheel - Remove

1. Remove the rear wheel .

3. Lower Arm B - Support

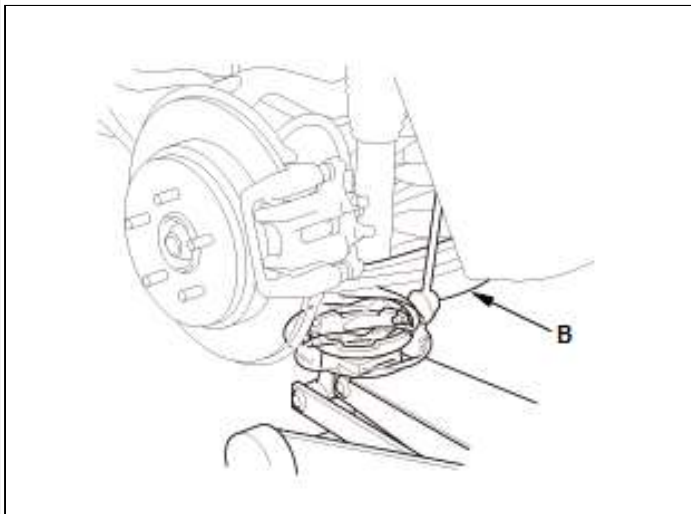

Courtesy of HONDA, U.S.A., INC.

1. Position a floor jack under lower arm B.

4. Rear Spring - Remove

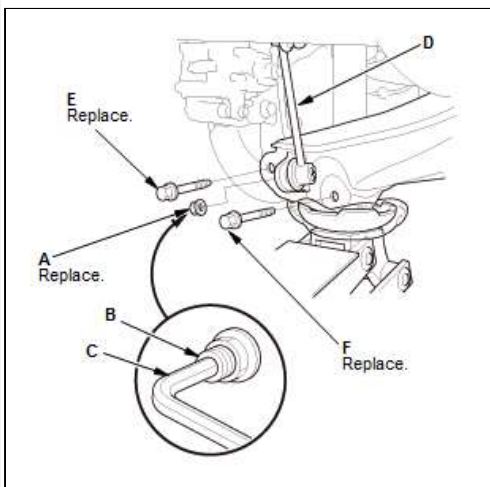

Courtesy of HONDA, U.S.A., INC.

1. Remove the flange nut (A) while holding the joint pin (B) with a hex wrench (C)
2. Disconnect the stabilizer link (D) from the lower arm B
3. Remove the flange bolt (E) that connects lower arm B to the knuckle
4. Remove the flange bolt (F) that connects lower arm B to the damper
5. Lower the floor jack gradually.

6. Remove the spring (A)
7. Remove the lower spring cushion (B)
8. Remove the flange bolt (C) that connects to the body

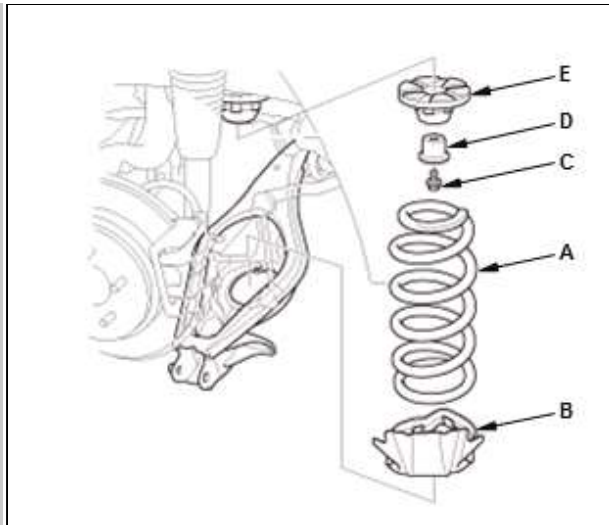

Courtesy of HONDA, U.S.A., INC.

9. Remove the spring mounting collar (D)
10. Remove spring mounting cushion (E).

REMOVAL / INSTALLATION > REAR SPRING REMOVAL AND INSTALLATION (2013-15) > INSTALLATION



NOTE:

- Refer to the Exploded View as needed during the following procedures.
- First install all the components, and lightly tighten the bolts and the nuts, then raise the suspension to load it with the vehicle's weight before fully tightening to the specified torque.

1. Rear Spring - Install

1. Install spring mounting cushion (A)
2. Install the spring mounting collar (C)
3. Install the flange bolt (D)
4. Install the spring (E) and the lower spring cushion (F). Align the bottom of the spring and the lower spring cushion with lower arm B as shown.

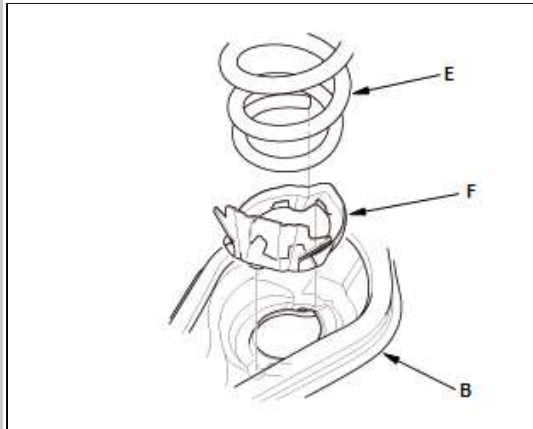
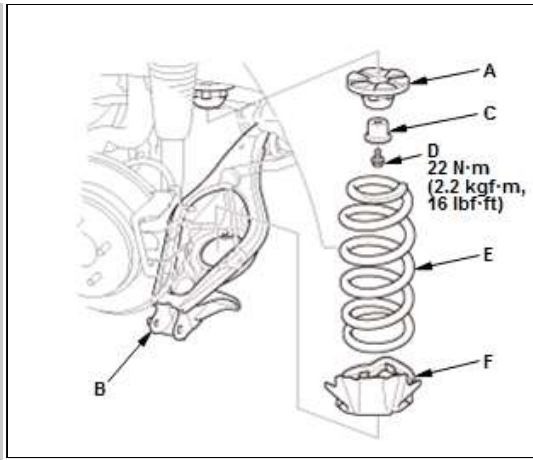

Courtesy of HONDA, U.S.A., INC. HONDA, U.S.A., INC.

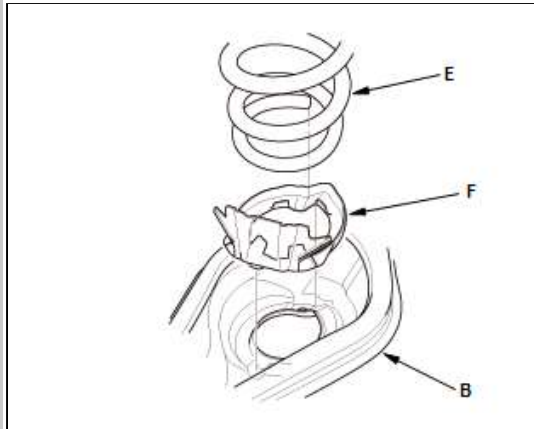
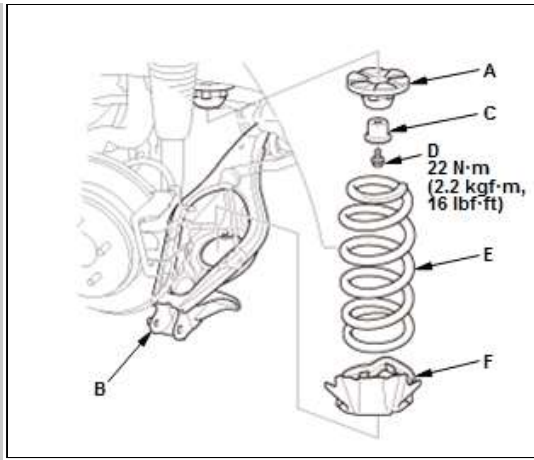

Courtesy of HONDA, U.S.A., INC. HONDA, U.S.A., INC.

Fig 1: Lower Arm B Bolts With Torque Specifications

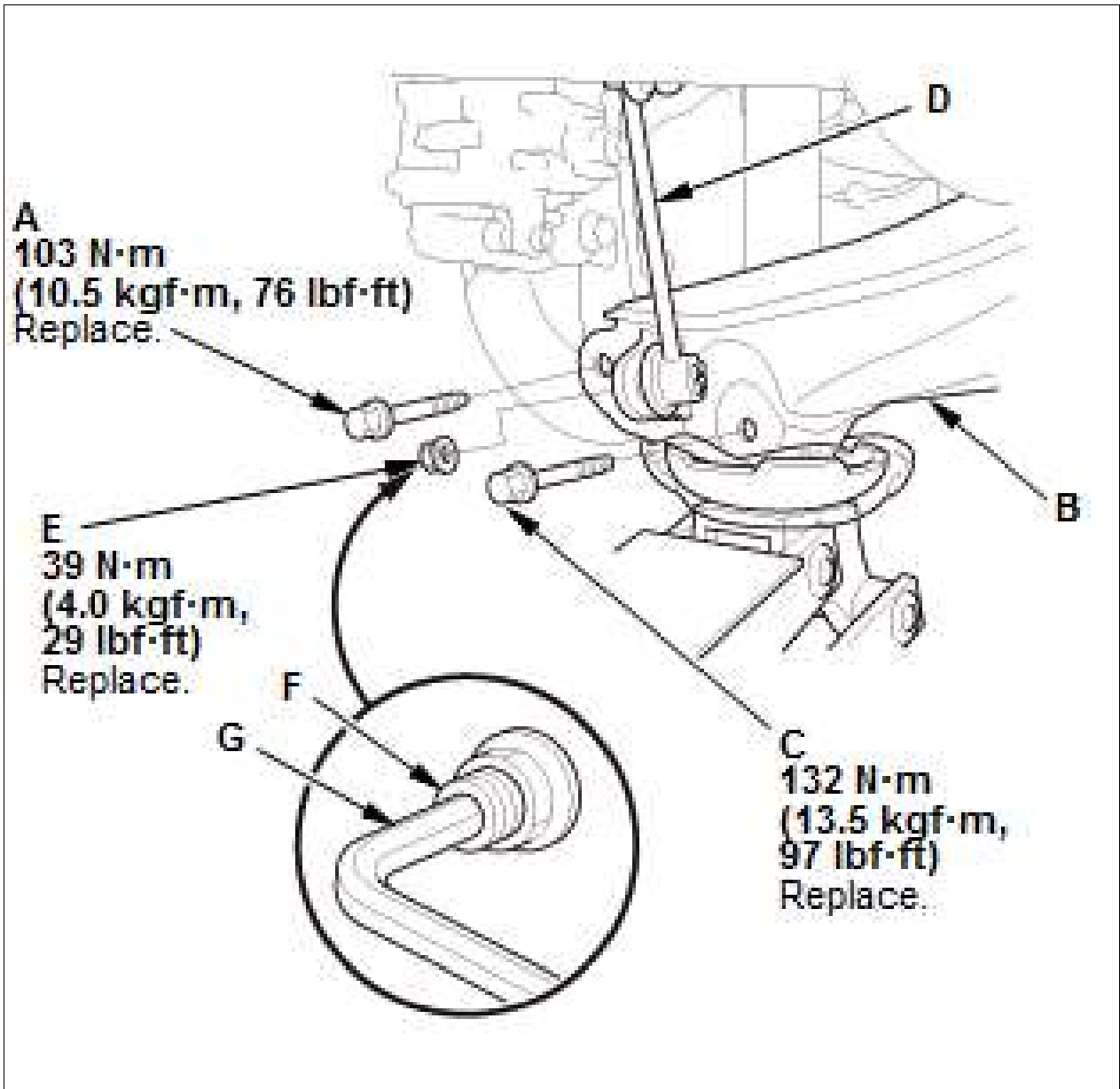

Courtesy of HONDA, U.S.A., INC.

5. Position a floor jack under lower arm B
6. Slowly raise the floor jack until you align the bolt hole with the holes in lower arm B and the knuckle
7. Install the new flange bolt (A)
8. Compress the damper by hand until you align the bolt hole with the holes in lower arm B and the damper
9. Install the new flange bolt (C)
10. Connect the stabilizer link (D) to lower arm B
11. Tighten the new flange nut (E) while holding the joint pin (F) with a hex wrench (G).

2. Rear Wheel - Install

- | |
|-----------------------------|
| 1. Install the rear wheel . |
|-----------------------------|

3. Wheel Alignment - Check

1. Check the wheel alignment, and adjust it if necessary .

REMOVAL / INSTALLATION > REAR SPRING REMOVAL AND INSTALLATION (2016-18) > EXPLODED / VIEW

Fig 1: Exploded View Of Rear Spring

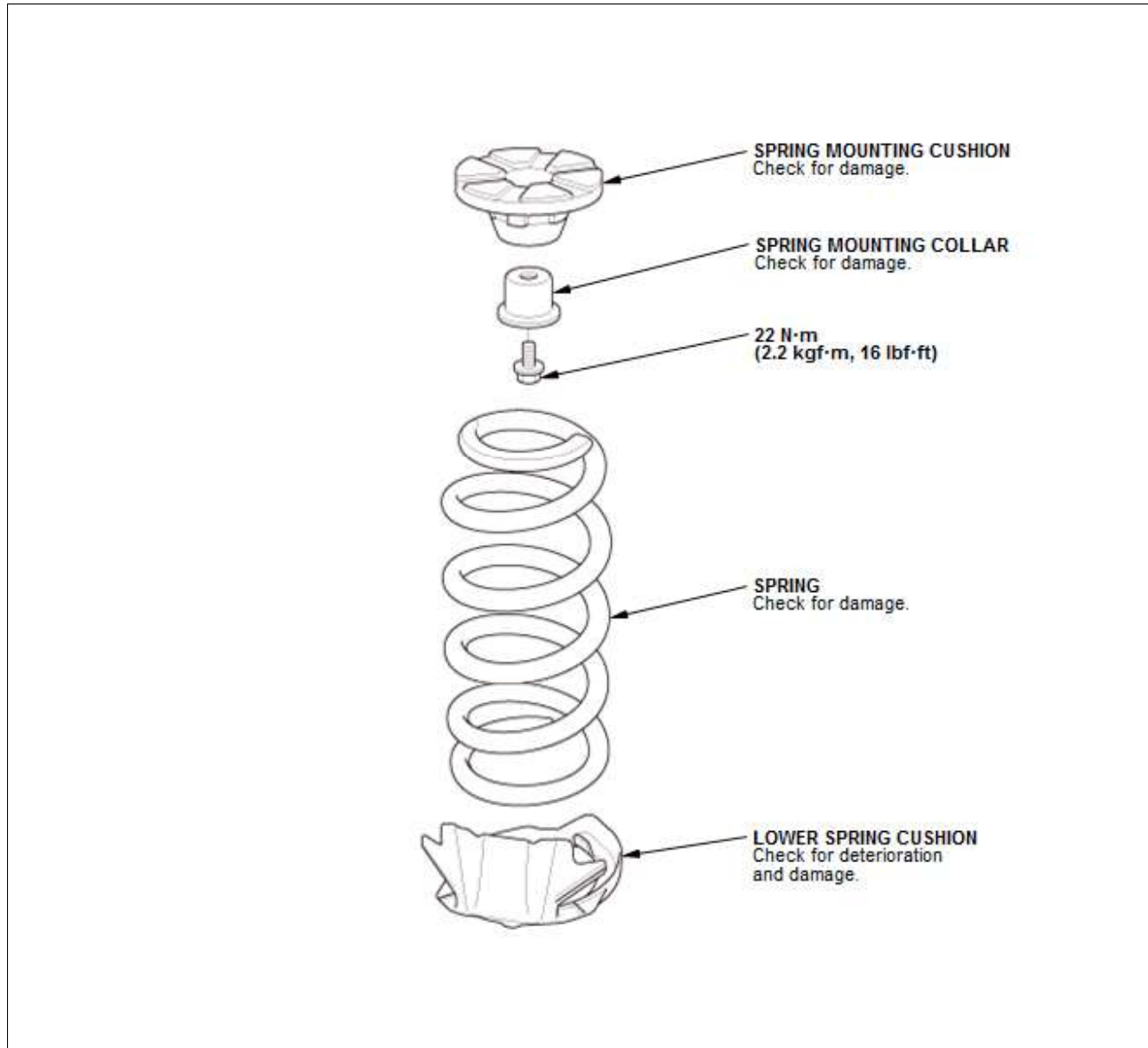

Courtesy of HONDA, U.S.A., INC.

REMOVAL / INSTALLATION > REAR SPRING REMOVAL AND INSTALLATION (2016-18) > REMOVAL



NOTE: Refer to the Exploded View as needed during the following procedures.

1. Vehicle - Lift
2. Rear Wheel - Remove
3. Lower Arm B - Support

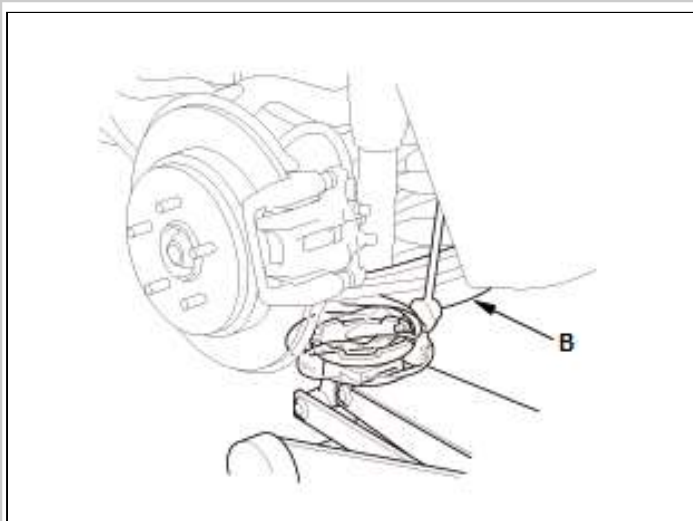

1. Position a floor jack under lower arm B.

Courtesy of HONDA, U.S.A., INC.

4. Rear Spring - Remove

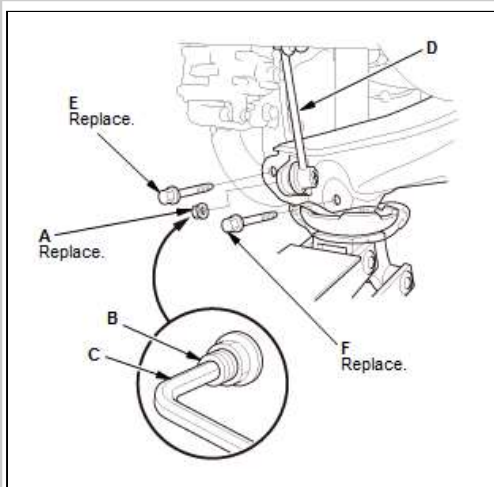

1. Remove the flange nut (A) while holding the joint pin (B) with a hex wrench (C)
2. Disconnect the stabilizer link (D) from the lower arm B
3. Remove the flange bolt (E) that connects lower arm B to the knuckle
4. Remove the flange bolt (F) that connects lower arm B to the damper
5. Lower the floor jack gradually.

Courtesy of HONDA, U.S.A., INC.

6. Remove the spring (A)
7. Remove the lower spring cushion (B)

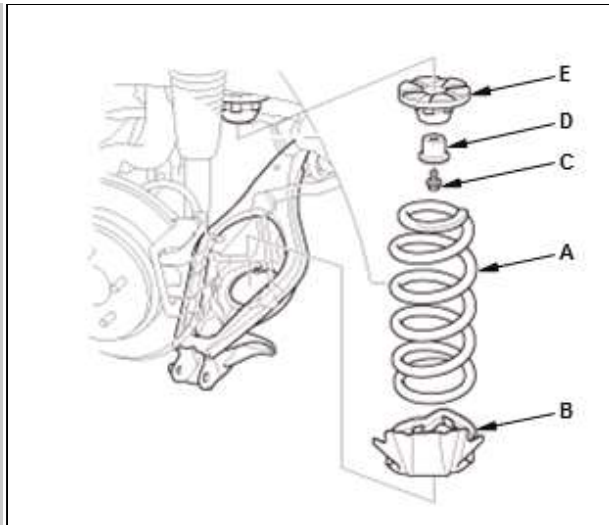

Courtesy of HONDA, U.S.A., INC.

8. Remove the flange bolt (C) that connects to the body
9. Remove the spring mounting collar (D)
10. Remove spring mounting cushion (E).

REMOVAL / INSTALLATION > REAR SPRING REMOVAL AND INSTALLATION (2016-18) > INSTALLATION



NOTE:

- Refer to the Exploded View as needed during the following procedures.
- Loosely install nuts and/or bolts to install the bushings, load the suspension with the vehicle's weight, and then tighten the nuts and/or bolts to the specified torque.

1. Rear Spring - Install

1. Install spring mounting cushion (A)
2. Install the spring mounting collar (C)
3. Install the flange bolt (D)
4. Install the spring (E) and the lower spring cushion (F). Align the bottom of the spring and the lower spring cushion with lower arm B as shown.

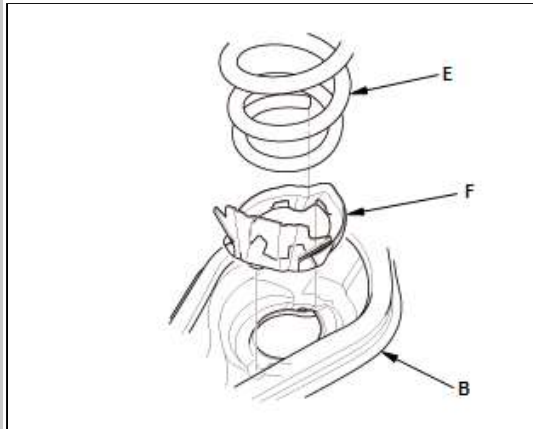
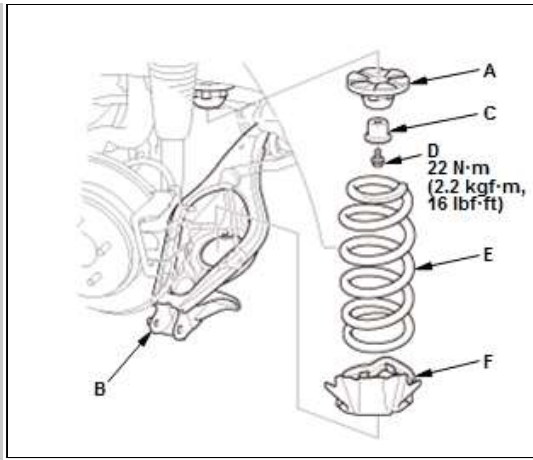

Courtesy of HONDA, U.S.A., INC. HONDA, U.S.A., INC.

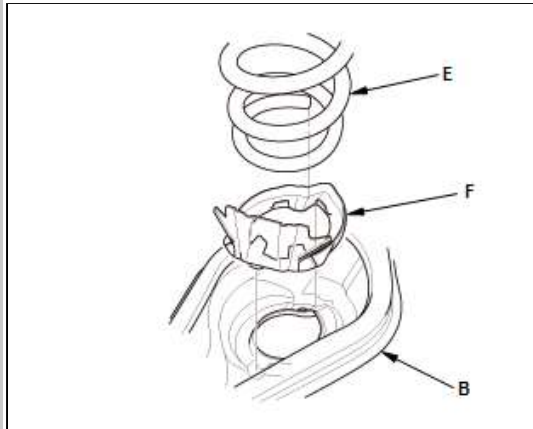
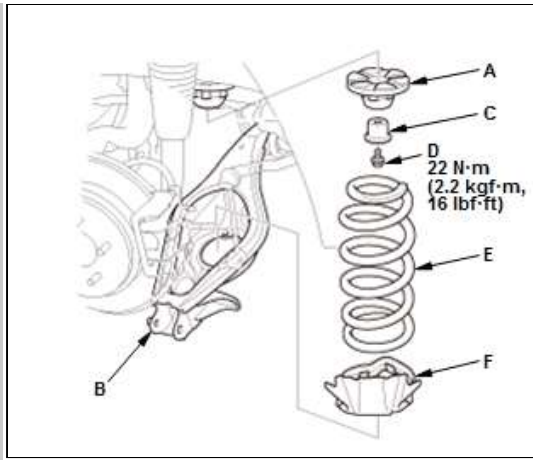

Courtesy of HONDA, U.S.A., INC. HONDA, U.S.A., INC.

Fig 1: Lower Arm B Bolts With Torque Specifications

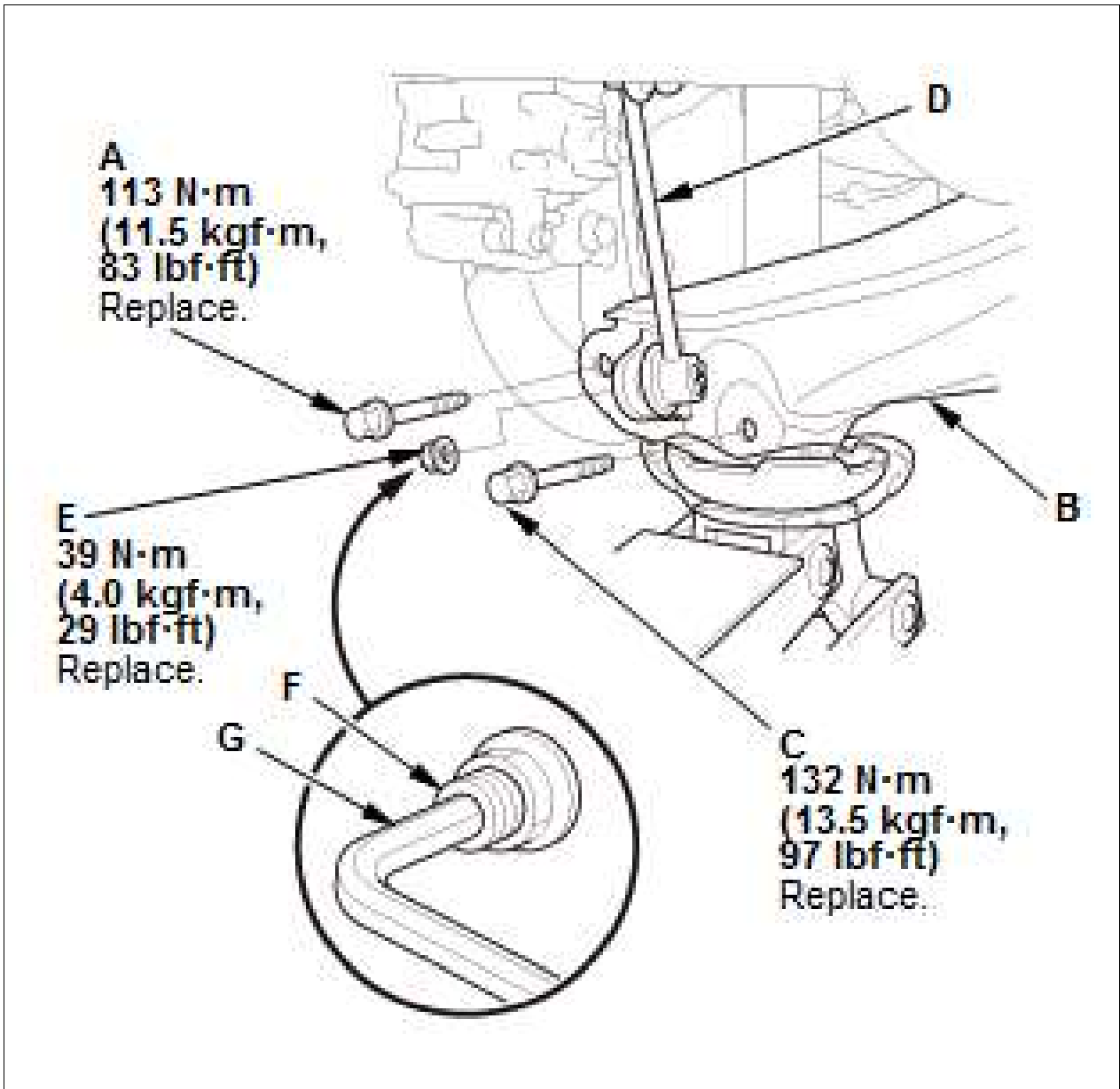

Courtesy of HONDA, U.S.A., INC.

5. Position a floor jack under lower arm B
 6. Slowly raise the floor jack until you align the bolt hole with the holes in lower arm B and the knuckle
 7. Install the new flange bolt (A)
 8. Compress the damper by hand until you align the bolt hole with the holes in lower arm B and the damper
 9. Install the new flange bolt (C)
 10. Connect the stabilizer link (D) to lower arm B
 11. Tighten the new flange nut (E) while holding the joint pin (F) with a hex wrench (G).
2. Rear Wheel - Install
 1. Install the rear wheel .
 3. Wheel Alignment - Check
 1. Check the wheel alignment, and adjust it if necessary .

REMOVAL / INSTALLATION > REAR STABILIZER BAR REMOVAL AND INSTALLATION (2013-18) > REMOVAL

1. Vehicle - Lift

1. Raise and support the vehicle .

2. Rear Wheels - Remove

1. Remove both rear wheels .

3. Stabilizer Link - Disconnect

1. Disconnect both sides of the stabilizer link from the stabilizer bar .

4. Stabilizer Bar - Remove

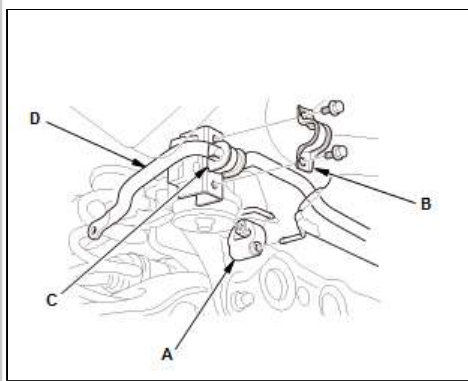

1. Remove the muffer rubber mounting (A)
2. Remove the bushing holders (B)
3. Remove the bushings (C)
4. Move the stabilizer bar (D) toward the passenger's side, and remove the stabilizer bar.

Courtesy of HONDA, U.S.A., INC.

REMOVAL / INSTALLATION > REAR STABILIZER BAR REMOVAL AND INSTALLATION (2013-18) > INSTALLATION

1. Stabilizer Bar - Install

Fig 1: Stabilizer Bar With Torque Specifications

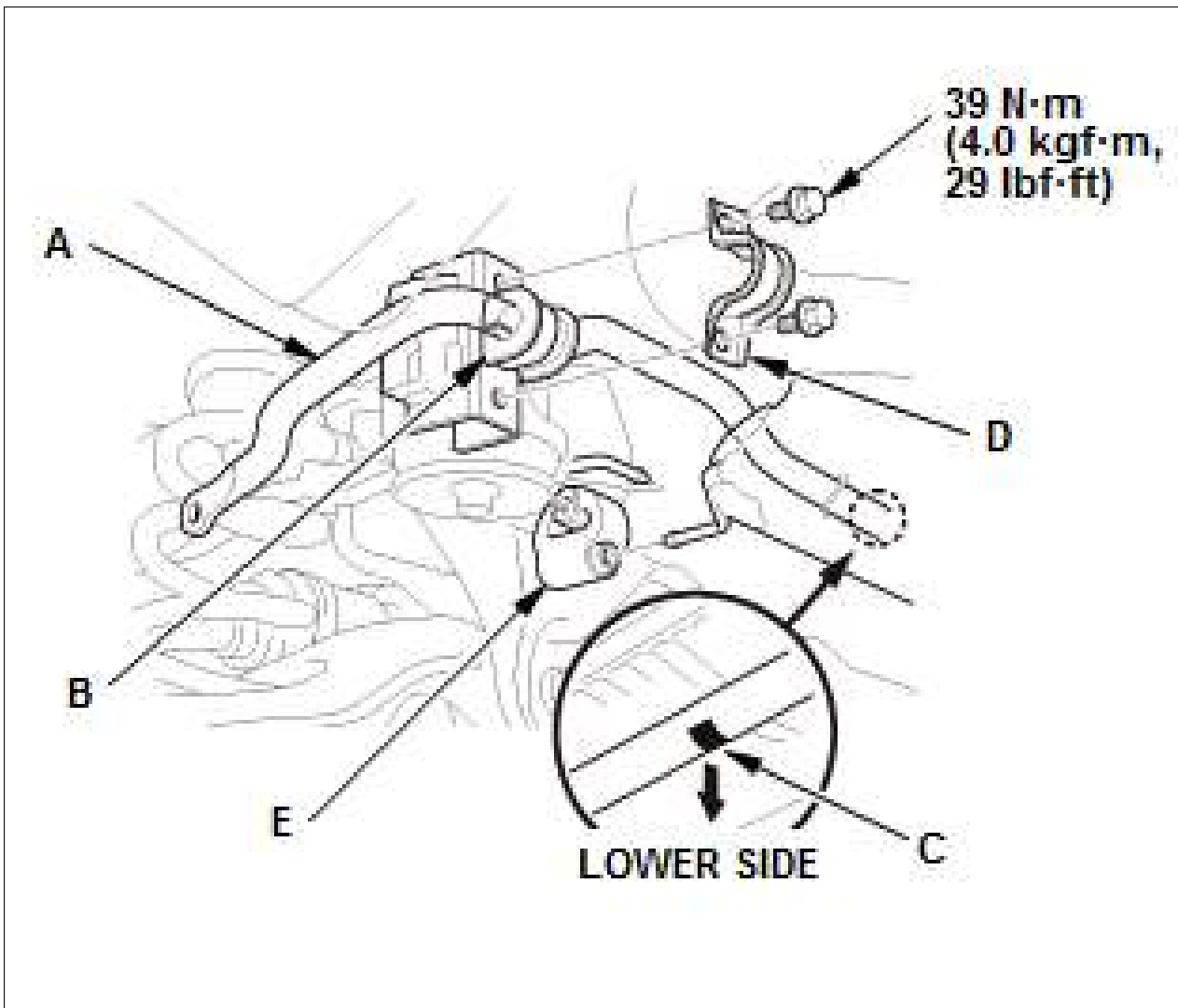

Courtesy of HONDA, U.S.A., INC.

1. Install the stabilizer bar (A)
2. Install the bushings (B).

 **NOTE:** The stabilizer bar has a paint mark (C) on the center facing downward

3. Install the bushing holders (D)
4. Install the muffler rubber mounting (E).

2. Stabilizer Link - Connect

1. Connect both sides of the stabilizer link to the stabilizer bar .

3. Rear Wheels - Install

1. Install both rear wheels .

4. Wheel Alignment - Check

1. Check the wheel alignment, and adjust it if necessary .

REMOVAL / INSTALLATION > REAR STABILIZER LINK REMOVAL AND INSTALLATION (2013-18) > REMOVAL

1. Vehicle - Lift

1. Raise and support the vehicle .

2. Rear Wheel - Remove

1. Remove the rear wheel .

3. Stabilizer Link - Remove

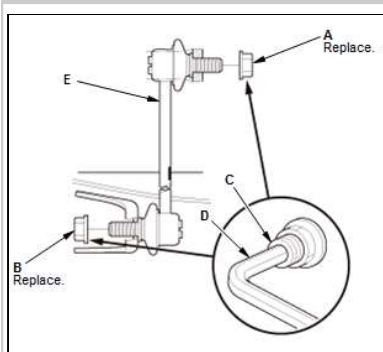

Courtesy of HONDA, U.S.A., INC.

1. Remove the self-locking nut (A) and the flange nut (B) while holding the respective joint pin (C) with a hex wrench (D)
2. Remove the stabilizer link (E).

REMOVAL / INSTALLATION > REAR STABILIZER LINK REMOVAL AND INSTALLATION (2013-18) > INSTALLATION

1. Stabilizer Link - Install

Fig 1: Stabilizer Link With Torque Specifications

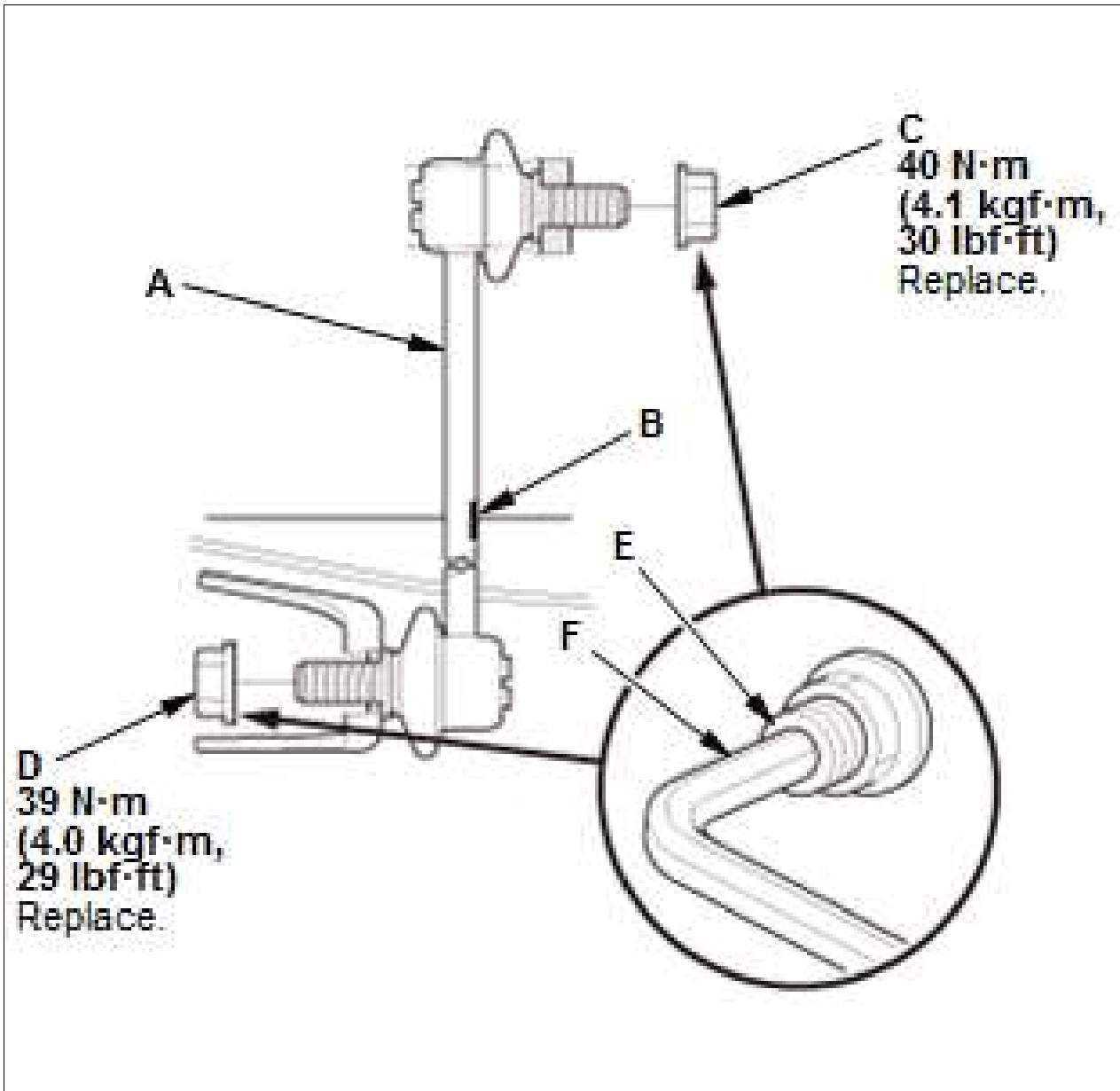

Courtesy of HONDA, U.S.A., INC.

1. Install the stabilizer link (A).

 **NOTE:** The stabilizer link has a paint mark (B). Align the paint mark facing inward

2. Install the new self-locking nut (C) and the new flange nut (D), and tighten them to the specified torque while holding the respective joint pin (E) with a hex wrench (F).

2. Rear Wheel - Install

1. Install the rear wheel .

3. Test Drive - Check

- | |
|--|
| <ol style="list-style-type: none">1. Test-drive the vehicle2. After 5 minutes of driving, tighten the self-locking nut again to the specified torque. |
|--|

REMOVAL / INSTALLATION > REAR TRAILING ARM REMOVAL AND INSTALLATION (2013-18) > REMOVAL

1. Vehicle - Lift

- | |
|--|
| <ol style="list-style-type: none">1. Raise and support the vehicle . |
|--|

2. Rear Wheel - Remove

- | |
|--|
| <ol style="list-style-type: none">1. Remove the rear wheel . |
|--|

3. Parking Brake Shoe - Remove

- | |
|--|
| <ol style="list-style-type: none">1. Remove the parking brake shoe . |
|--|

4. Parking Brake Cable - Remove

- | |
|--|
| <ol style="list-style-type: none">1. Remove the parking brake cable from the backing plate . |
|--|

5. Lower Arm B - Support

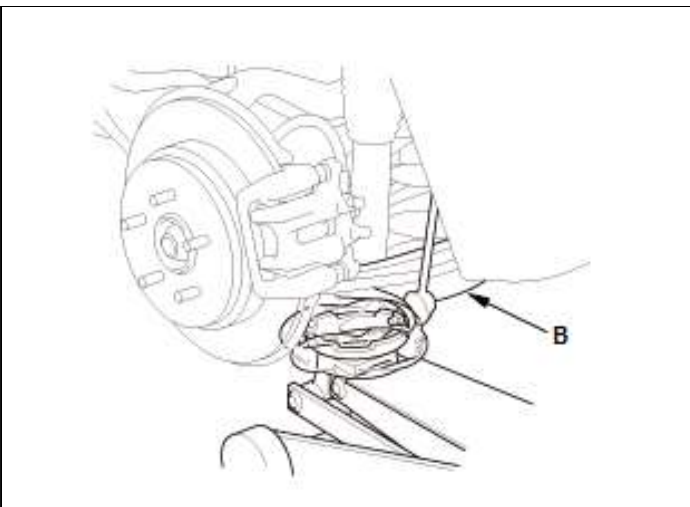
	<ol style="list-style-type: none">1. Position a floor jack under lower arm B.
<p>Courtesy of HONDA, U.S.A., INC.</p>	

6. Trailing Arm - Remove

- | | |
|--|---|
| | <ol style="list-style-type: none">1. Remove the parking brake cable mounting bracket (A). |
|--|---|

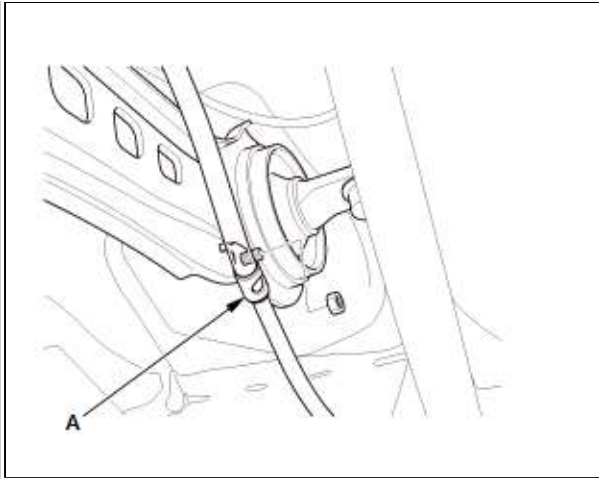

Courtesy of HONDA, U.S.A., INC.

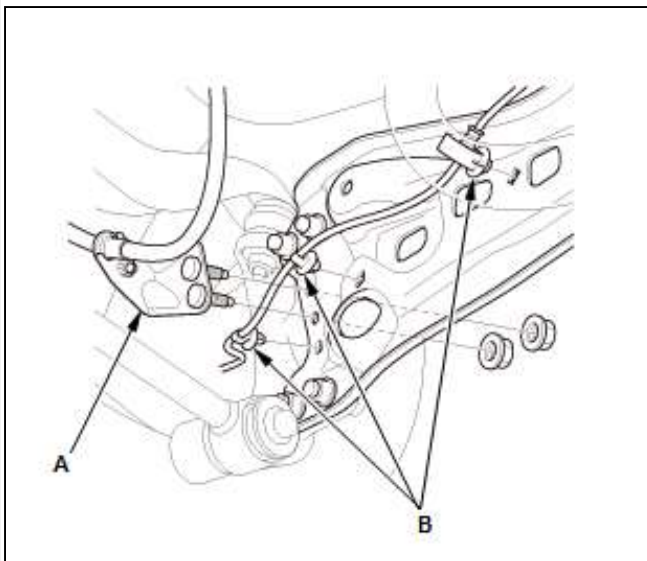

Courtesy of HONDA, U.S.A., INC.

2. Remove the brake hose mounting bracket (A)
3. Remove the wheel speed sensor clips (B).

4. Remove the trailing arm (A).

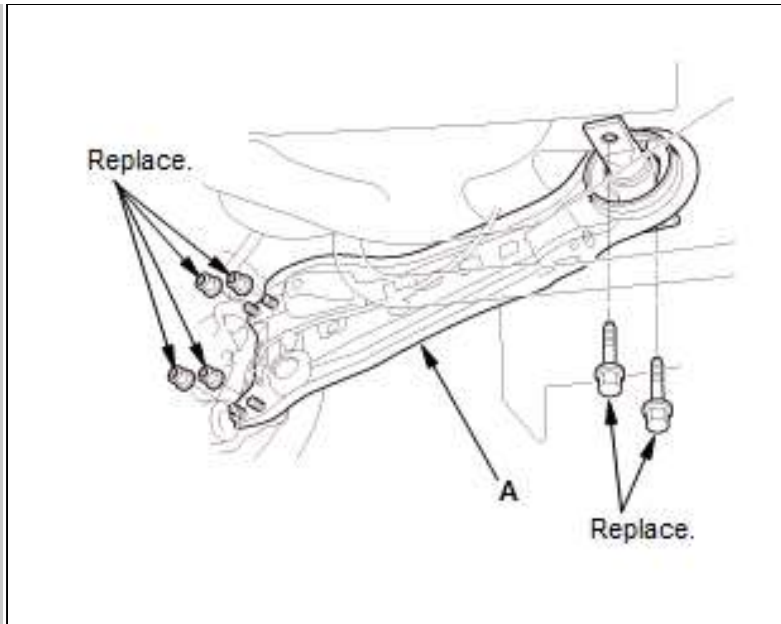

Courtesy of HONDA, U.S.A., INC.

REMOVAL / INSTALLATION > REAR TRAILING ARM REMOVAL AND INSTALLATION (2013-18) > INSTALLATION

 **NOTE:** First install all the components, and lightly tighten the bolts and the nuts, then raise the suspension to load it with the vehicle's weight before fully tightening to the specified torque.

1. Trailing Arm - Install

Fig 1: Trailing Arm With Torque Specifications

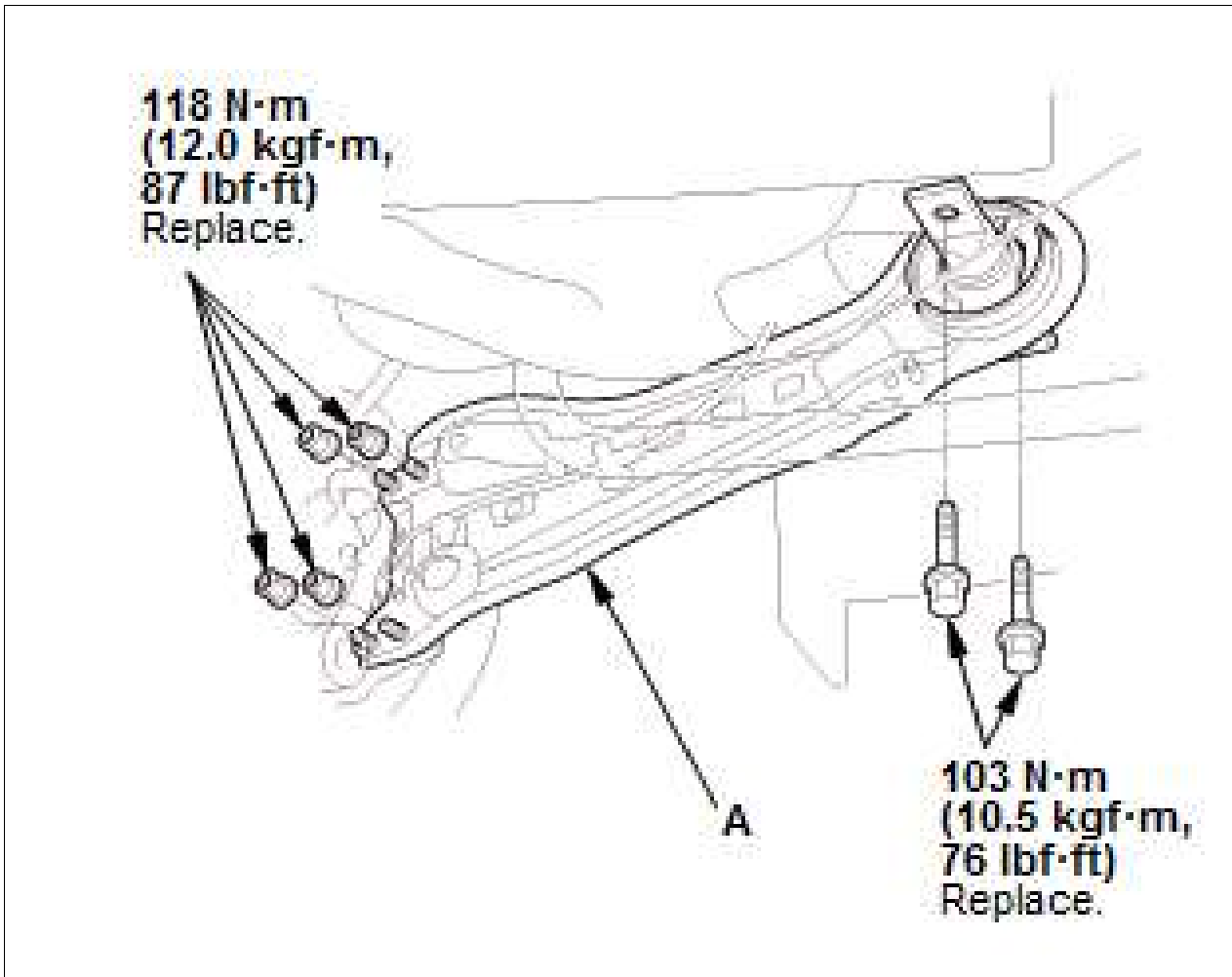

Courtesy of HONDA, U.S.A., INC.

1. Install the trailing arm (A) with the new flange bolts and the new flange nuts.

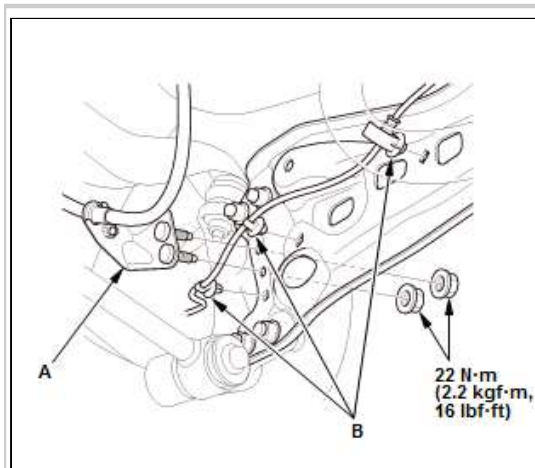

Courtesy of HONDA, U.S.A., INC.

2. Install the brake hose mounting bracket (A).

 **NOTE:** Check the brake hose for interference and twisting

3. Install the wheel speed sensor clips (B).

4. Install the parking brake cable mounting

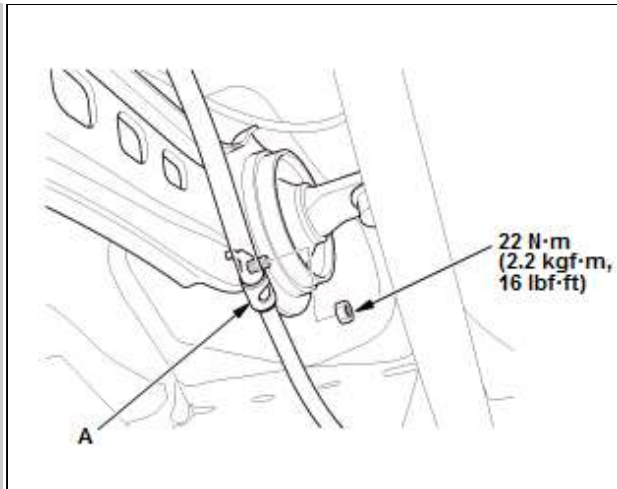

bracket (A).

Courtesy of HONDA, U.S.A., INC.

2. Parking Brake Cable - Install

1. Install the parking brake cable to the backing plate .

3. Parking Brake Shoe - Install

1. Install the parking brake shoe .

4. Rear Wheel - Install

1. Install the rear wheel .

5. Wheel Alignment - Check

1. Check the wheel alignment, and adjust it if necessary .

REMOVAL / INSTALLATION > REAR UPPER ARM REMOVAL AND INSTALLATION (2013-15)

Special Tools Required

Image	Description/Tool Number
	Ball Joint Thread Protector, 12 mm 07AAF-SDAA100

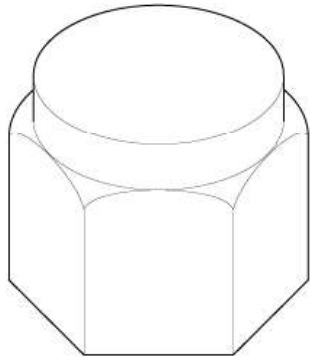

Courtesy of HONDA, U.S.A., INC.



Ball Joint Remover, 32 mm 07MAC-SL00102

Courtesy of HONDA, U.S.A., INC.

REMOVAL / INSTALLATION > REAR UPPER ARM REMOVAL AND INSTALLATION (2013-15) > REMOVAL

1. Vehicle - Lift

1. Raise and support the vehicle .

2. Rear Wheel - Remove

1. Remove the rear wheel .

3. Lower Arm B - Support

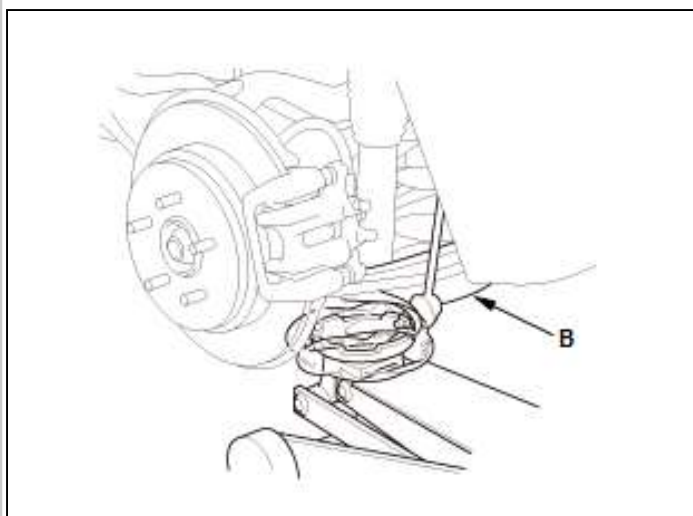

Courtesy of HONDA, U.S.A., INC.

1. Position a floor jack under lower arm B.

4. Upper Arm - Remove

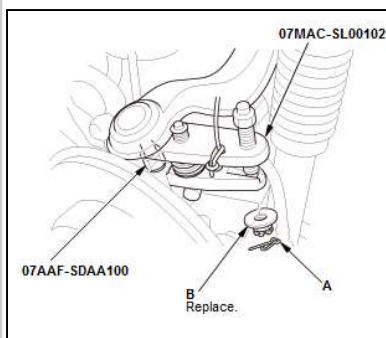

Courtesy of HONDA, U.S.A., INC.

1. Remove the lock pin (A).
2. Remove the castle nut (B).
3. Disconnect the upper arm ball joint from the knuckle using the ball joint thread protector and the ball joint remover .



NOTE: *Be careful not to damage the ball joint boot when installing the ball joint remover.*

4. Remove the upper arm (A).

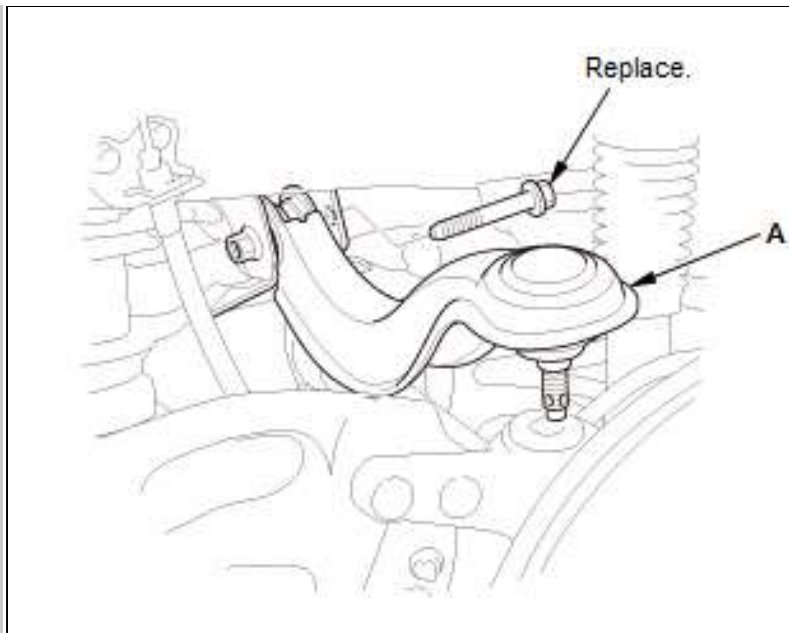

Courtesy of HONDA, U.S.A., INC.

REMOVAL / INSTALLATION > REAR UPPER ARM REMOVAL AND INSTALLATION (2013-15) > INSTALLATION

 **NOTE:** First install all the components, and lightly tighten the bolts and the nuts, then raise the suspension to load it with the vehicle's weight before fully tightening to the specified torque.

1. Upper Arm - Install

Fig 1: Upper Arm With Torque Specifications

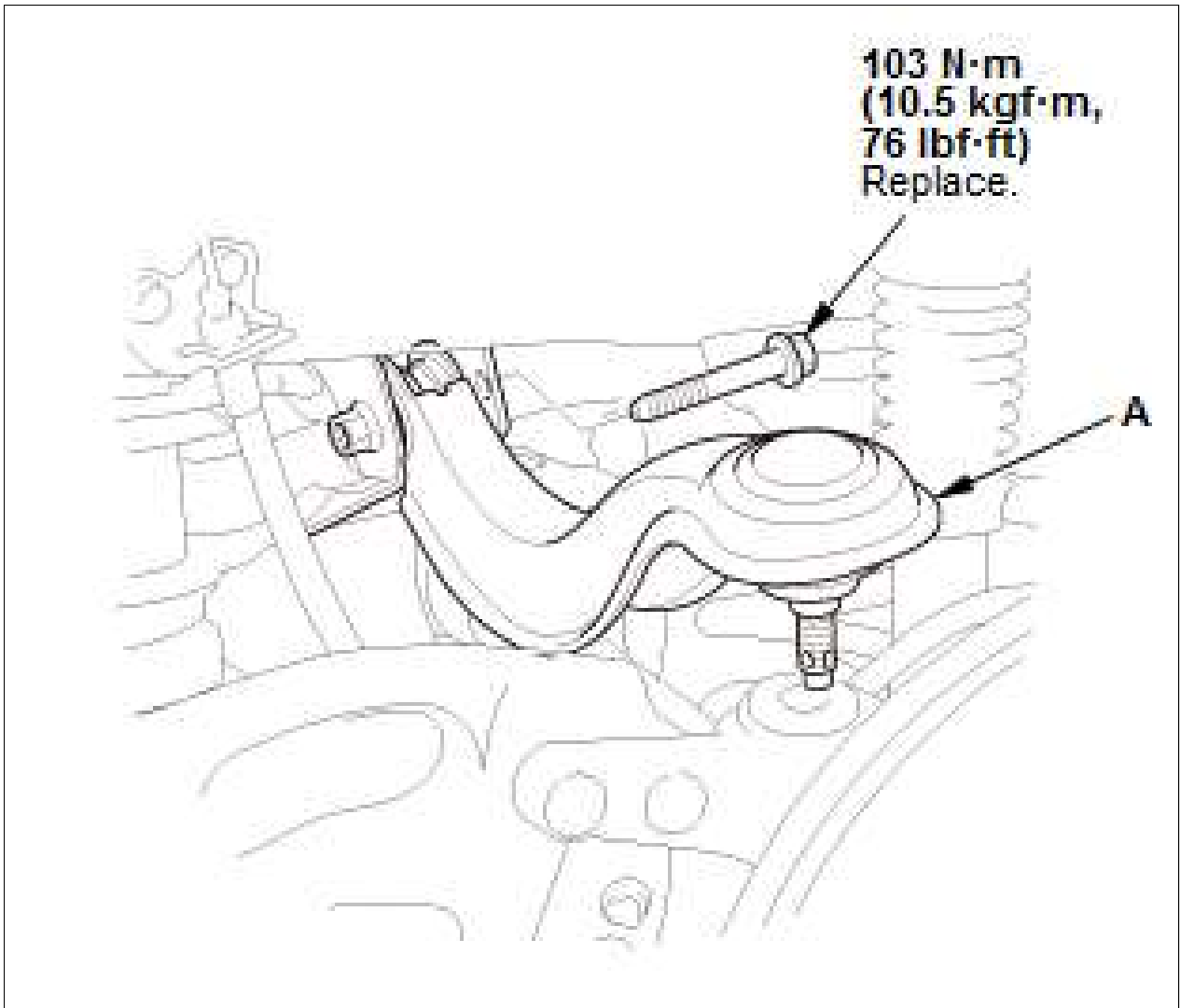

Courtesy of HONDA, U.S.A., INC.

1. Install the upper arm (A) with the new flange bolts.

Fig 2: Upper Arm Ball Joint Nut With Torque Specifications

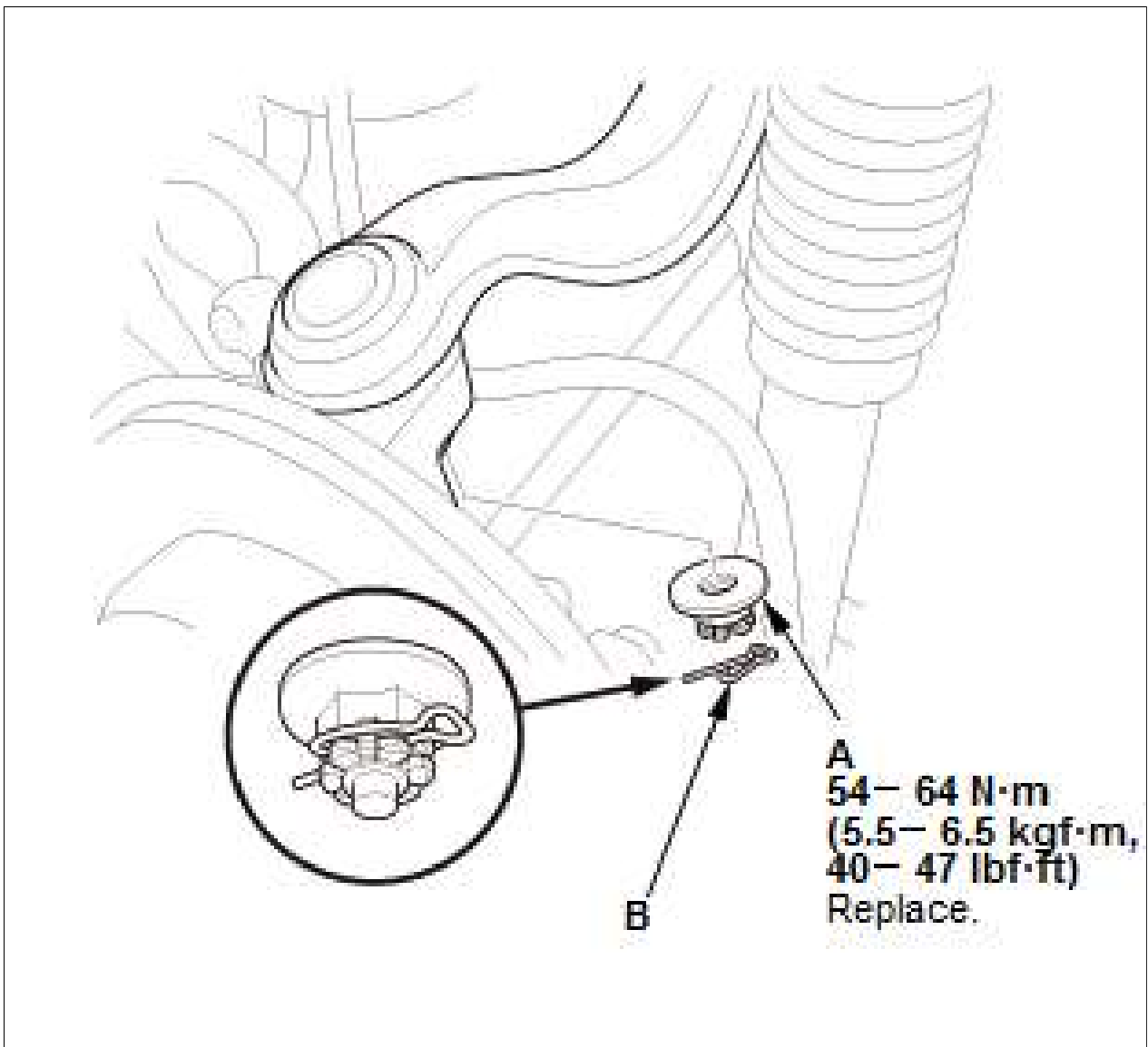

Courtesy of HONDA, U.S.A., INC.

2. Connect the upper arm ball joint to the knuckle
3. Install the new castle nut (A).

 **NOTE:** Torque the castle nut to the lower torque specification, then tighten it only far enough to align the slot with the ball joint pin hole. Do not align the castle nut by loosening it

4. Install the lock pin (B) as shown.

2. Rear Wheel - Install

1. Install the rear wheel .

3. Wheel Alignment - Check

1. Check the wheel alignment, and adjust it if necessary .

REMOVAL / INSTALLATION > REAR UPPER ARM REMOVAL AND INSTALLATION (2016-18)

Special Tools Required

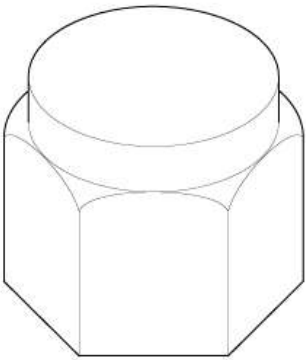
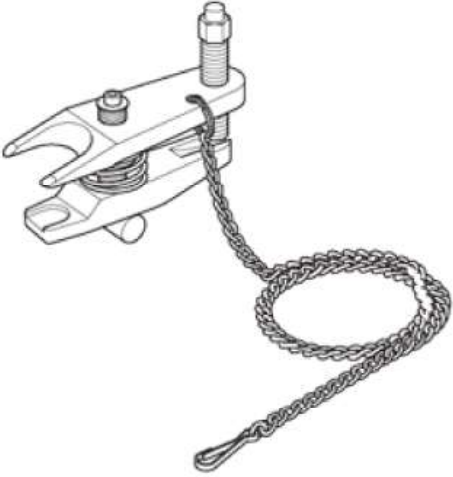
Image	Description/Tool Number
 <p data-bbox="167 1129 477 1155">Courtesy of HONDA, U.S.A., INC.</p>	<p data-bbox="987 856 1422 924">Ball Joint Thread Protector, 12 mm 07AAF-SDAA100</p>
 <p data-bbox="167 1822 477 1848">Courtesy of HONDA, U.S.A., INC.</p>	<p data-bbox="987 1549 1435 1617">Ball Joint Remover, 32 mm 07MAC-SL00102</p>

REMOVAL / INSTALLATION > REAR UPPER ARM REMOVAL AND INSTALLATION (2016-18) > REMOVAL / INSTALLATION

1. Vehicle - Lift
2. Rear Wheel - Remove
3. Lower Arm B - Support

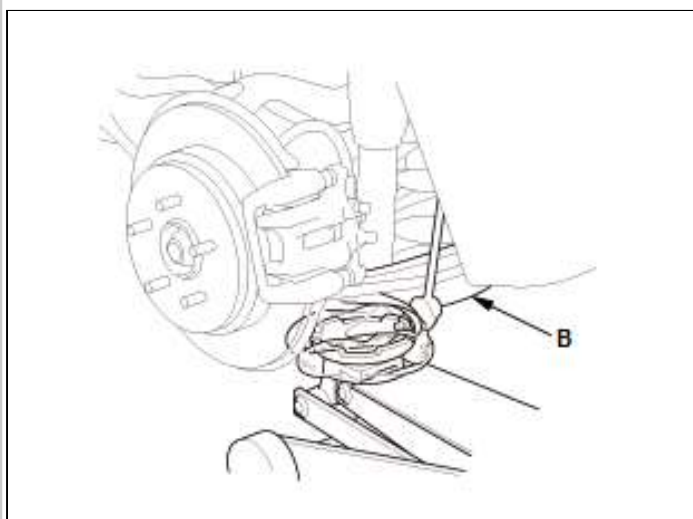

Courtesy of HONDA, U.S.A., INC.

1. Position a floor jack under lower arm B.

4. Upper Arm - Remove

Fig 1: Upper Arm With Torque Specifications

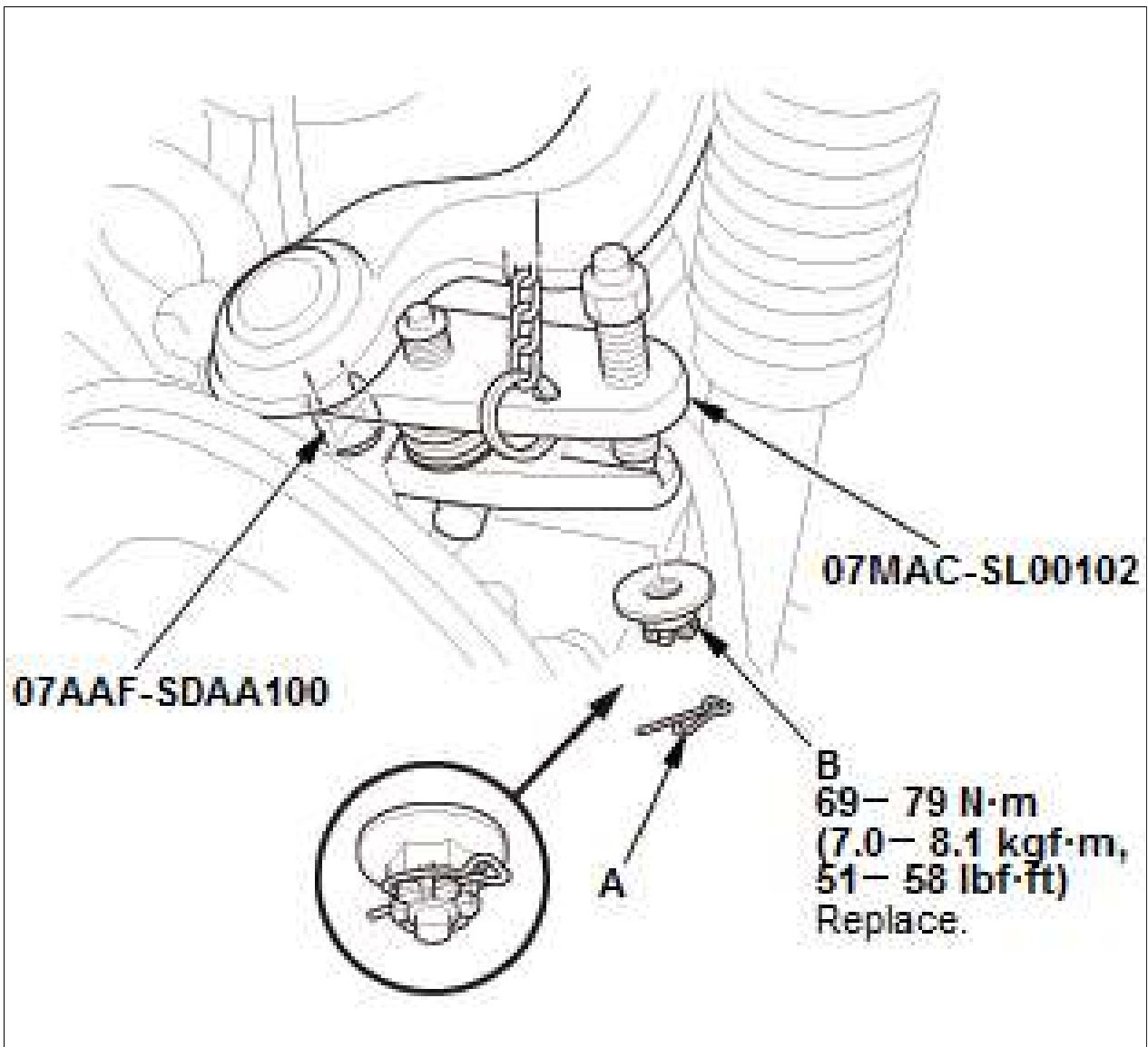

Courtesy of HONDA, U.S.A., INC.

1. Remove the lock pin (A).

 **NOTE:** During installation, install the lock pin as shown after tightening the new castle nut.

2. Remove the castle nut (B). Disconnect the upper arm ball joint from the knuckle using the ball joint thread protector and the ball joint remover .

 **NOTE:** Be careful not to damage the ball joint boot when installing the ball joint remover.

Fig 2: Upper Arm Bolts With Torque Specifications



Courtesy of HONDA, U.S.A., INC.

4. Remove the upper arm (A).

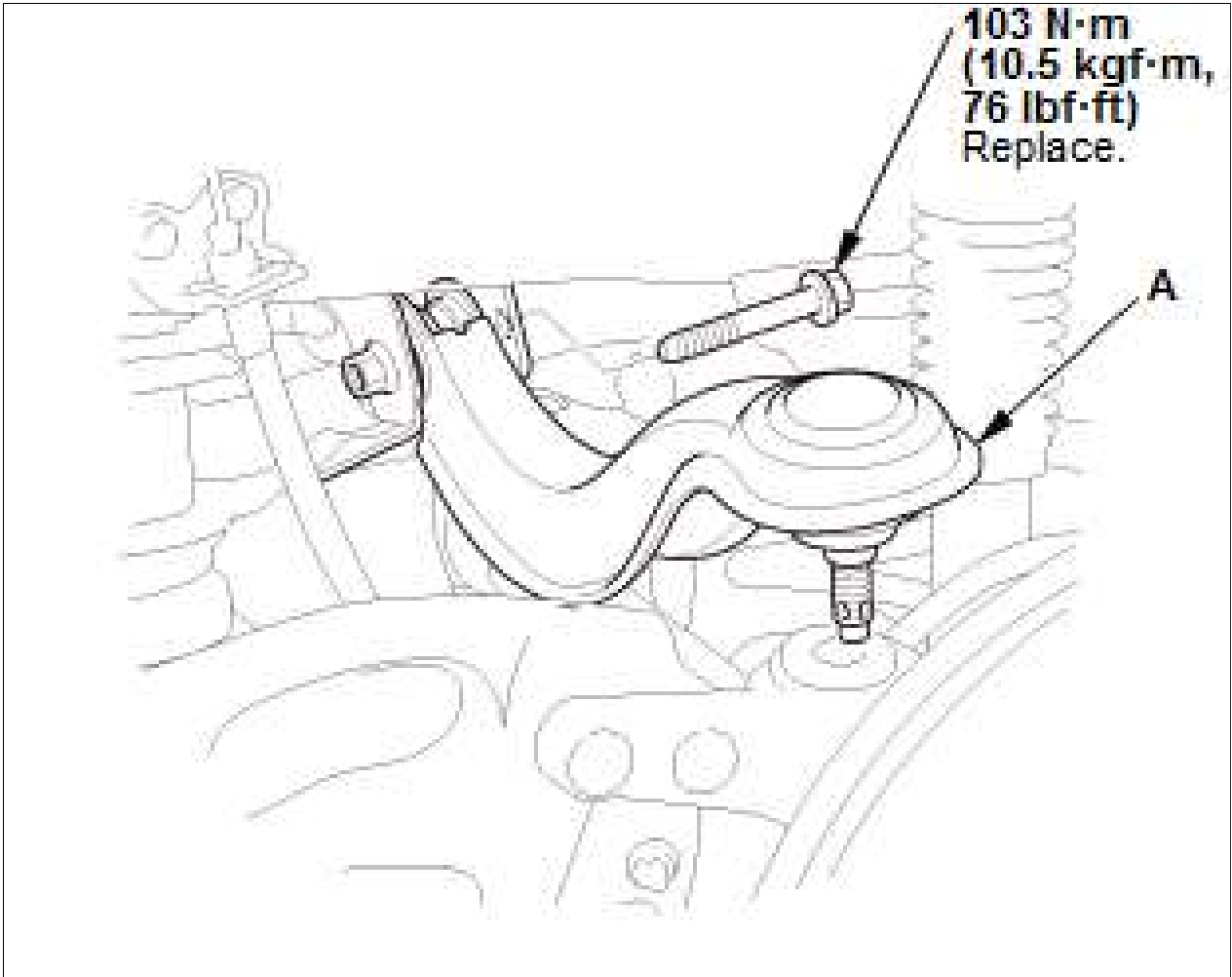

NOTE: Use the new flange bolt during reassembly

5. All Removed Parts - Install

1. Install the all removed parts in the reverse order of removal, and note these items



NOTE:

1. Loosely install nuts and/or bolts to install the bushings, load the suspension with the vehicle's weight, and then tighten the nuts and/or bolts to the specified torque.
2. Be careful not to damage the ball joint boot when connecting the knuckle.
3. Before connecting the ball joint, degrease the threaded section and the tapered portion of the ball joint pin, the

ball joint connecting hole, the threaded section, and the mating surfaces of the castle nut.

4. Torque the castle nut to the lower torque specification, then tighten it only far enough to align the slot with the ball joint pin hole. Do not align the castle nut by loosening it.

6. Wheel Alignment - Check

REMOVAL / INSTALLATION > TIRE PRESSURE SENSOR REMOVAL AND INSTALLATION (2013-18) > REMOVAL

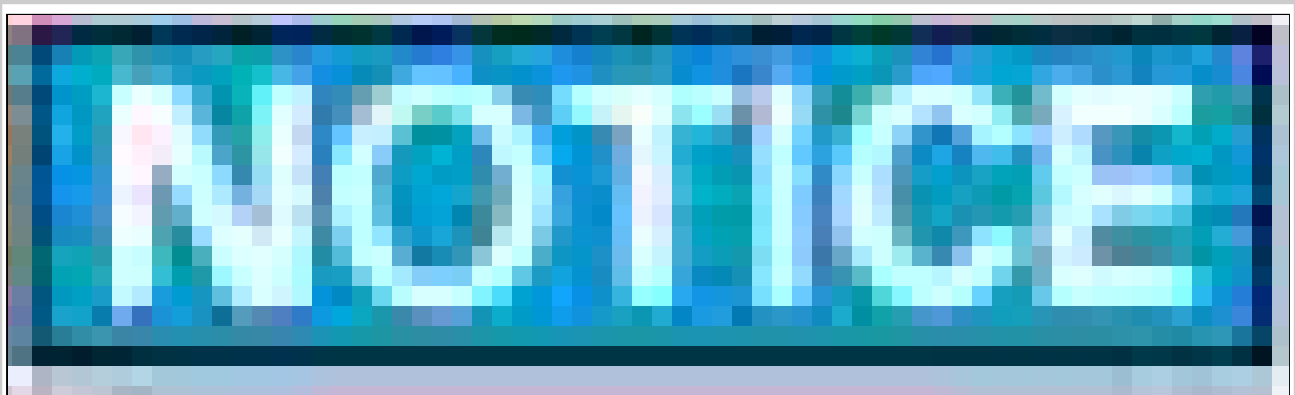

Courtesy of HONDA, U.S.A., INC.

Each tire pressure sensor contains a lithium anode battery that is not removable. The complete tire pressure sensor should be disposed of according to local battery disposal guidelines or requirements. An improperly disposed of battery can be harmful to the environment.

1. Vehicle - Lift

1. Raise and support the vehicle .

2. Wheel with the Faulty Tire Pressure Sensor - Remove

1. Remove the wheel with the faulty tire pressure sensor .

3. Tire Pressure Sensor - Remove

1. Remove the tire valve stem cap and the valve stem core to deflate the tire
2. Remove any balance weights
3. Break the bead loose from the wheel with a commercially available tire changer (A).

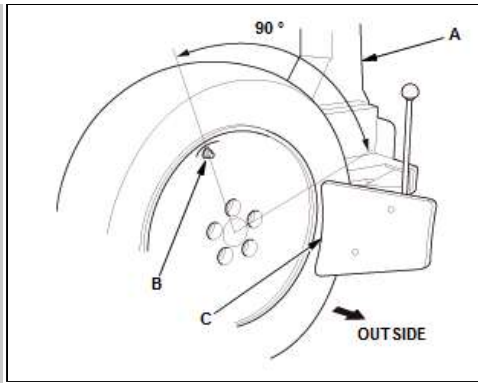

Courtesy of HONDA, U.S.A., INC.

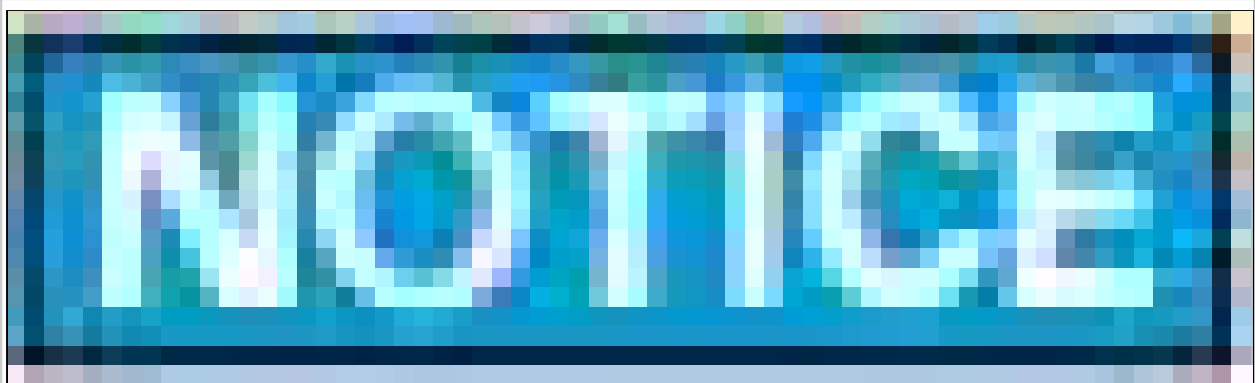

Courtesy of HONDA, U.S.A., INC.

Note these items to avoid damaging the tire pressure sensor:

1. Do the outside of the wheel first.
2. Position the wheel as shown so the valve stem (B) is 90 degrees from the bead breaker (C) as shown.
3. Do not position the bead breaker of the tire changer too close to the rim.

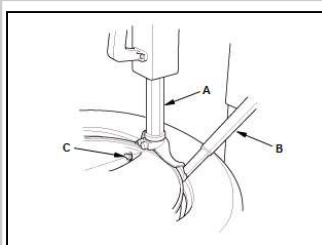

Courtesy of HONDA, U.S.A., INC.

4. Position the wheel so that the tire machine (A) and the tire iron (B) are next to the valve stem (C), and will move away from it when the machine starts
5. Remove the tire from the wheel.

6. Remove the valve stem nut (A) and the washer (B).

 **NOTE:** Check the nut and the washer; if they are deteriorated or damaged, replace

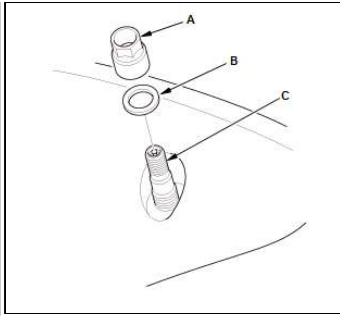

Courtesy of HONDA, U.S.A., INC.

them with new ones during reassembly

7. Remove the tire pressure sensor with the valve stem (C).

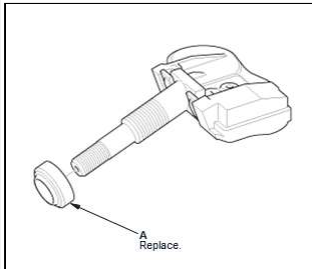

Courtesy of HONDA, U.S.A., INC.

8. Remove and discard the valve stem grommet (A).



NOTE:

1. *The valve stem grommet might stay in the wheel; make sure you remove it.*
2. *Always use a new valve stem grommet whenever the tire pressure sensor has been removed from the wheel, or when replacing the tire.*

REMOVAL / INSTALLATION > TIRE PRESSURE SENSOR REMOVAL AND INSTALLATION (2013-18) > INSTALLATION

1. Tire Pressure Sensor - Install

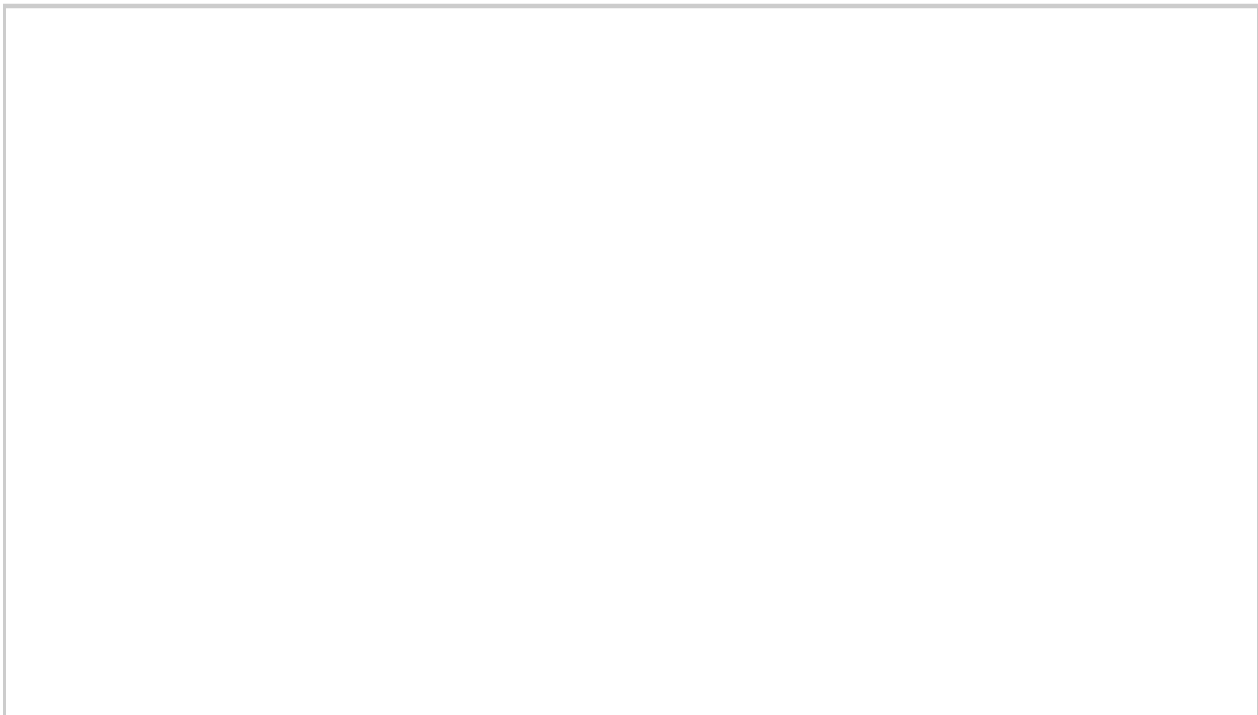

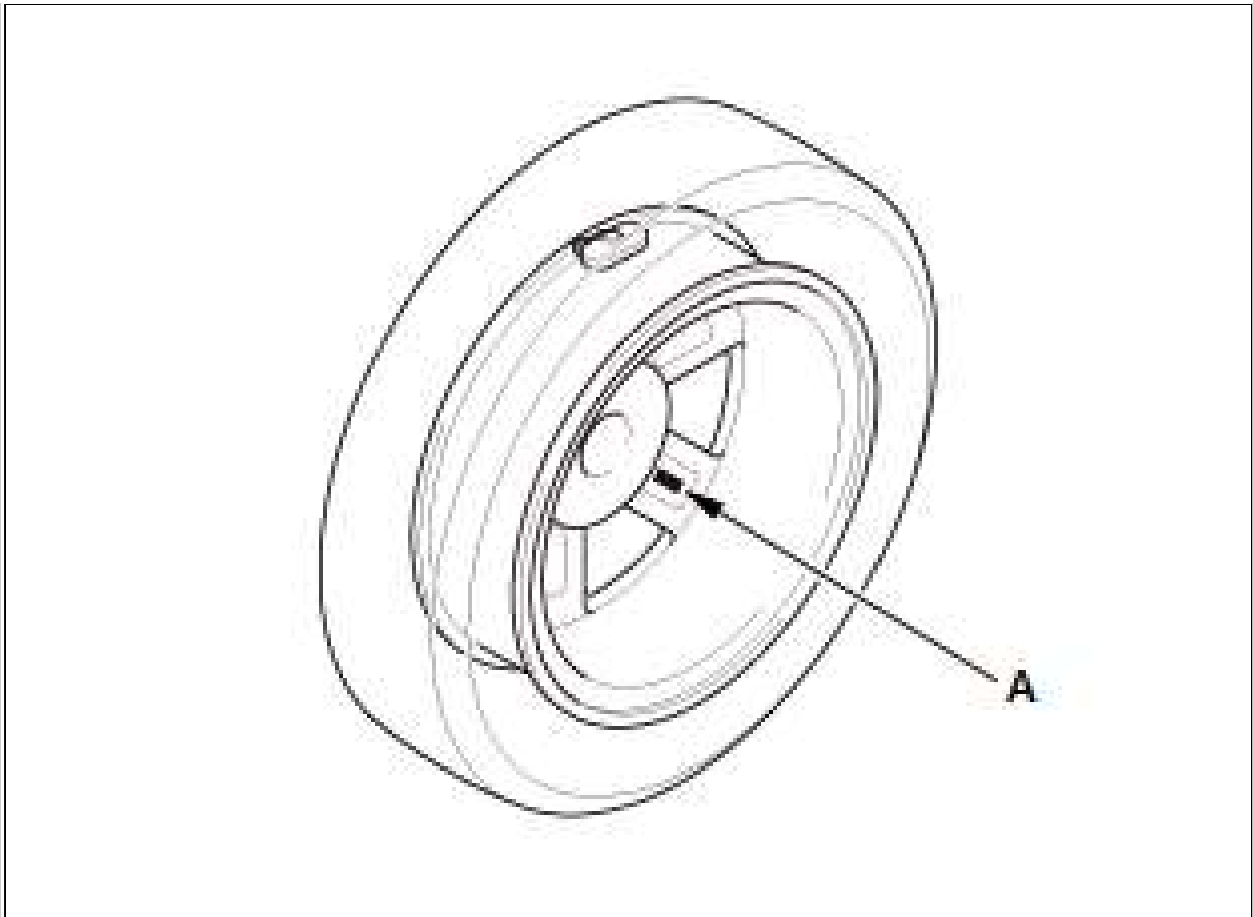

Courtesy of HONDA, U.S.A., INC.

NOTE: Use only wheels that have a "TPMS" stamp (A) on the inside or outside of the wheels.

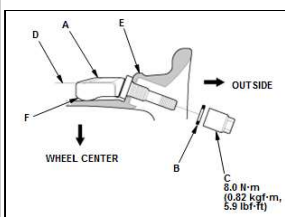

1. Before installing the tire pressure sensor, clean the mating surfaces on the sensor and the wheel
2. Install the tire pressure sensor (A)
3. Install the washer (B) and the valve stem nut (C).

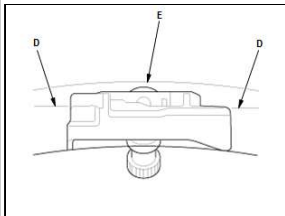

Courtesy of HONDA, U.S.A., INC.
 INC.HONDA, U.S.A., INC.

NOTE: Install the tire pressure sensor so that the sensor housing surface (D) is below the protrusion (E) of the wheel to prevent the sensor housing from being caught on the bead of the tire when installing the tire. Be sure to always mount the tire pressure sensor with the feet (F) in the downward position toward the wheel

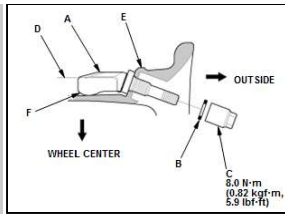

4. Tighten the valve stem nut to the specified torque while holding the tire pressure sensor.



NOTE:

1. Do not use air or electric impact tools to tighten the valve stem nut.
2. Do not twist the tire pressure sensor to adjust its position with the wheel, as this will damage or deform the valve stem grommet.

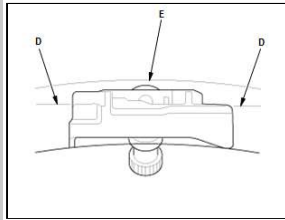

Courtesy of HONDA, U.S.A., INC. HONDA, U.S.A., INC.

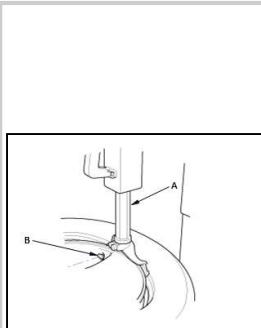

5. Lube the tire bead sparingly with a paste-type tire mounting lubricant, and position the wheel so that the tire machine (A) is next to the valve stem (B) and will move away from it when the machine starts

6. Install the tire onto the wheel

7. With a dry air source, inflate the tire to 300 kPa (3.06 kgf/cm², 43.5 psi) to seat the tire bead to the rim.



NOTE: Make sure the tire bead is seated on both sides of the rim evenly

Courtesy of HONDA, U.S.A., INC.

2. Adjust the tire pressure
3. Install the valve stem cap
4. Check and adjust the wheel balance.

2. Wheel with the Tire Pressure Sensor - Install

1. Install the wheel with the tire pressure sensor .

3. Tire Pressure Sensor ID - Memorize

1. Connect the HDS, and memorize the tire pressure sensor IDs - Refer to: Memorizing the Tire Pressure Sensor ID (2013-15), or Memorizing the Tire Pressure Sensor ID (2016-18) . Do not memorize the IDs automatically.

REMOVAL / INSTALLATION > TIRE SEALANT BOTTLE REPLACEMENT (2016-18) > REPLACEMENT

1. Tire Sealant Bottle - Remove

1. Remove the cover (A)

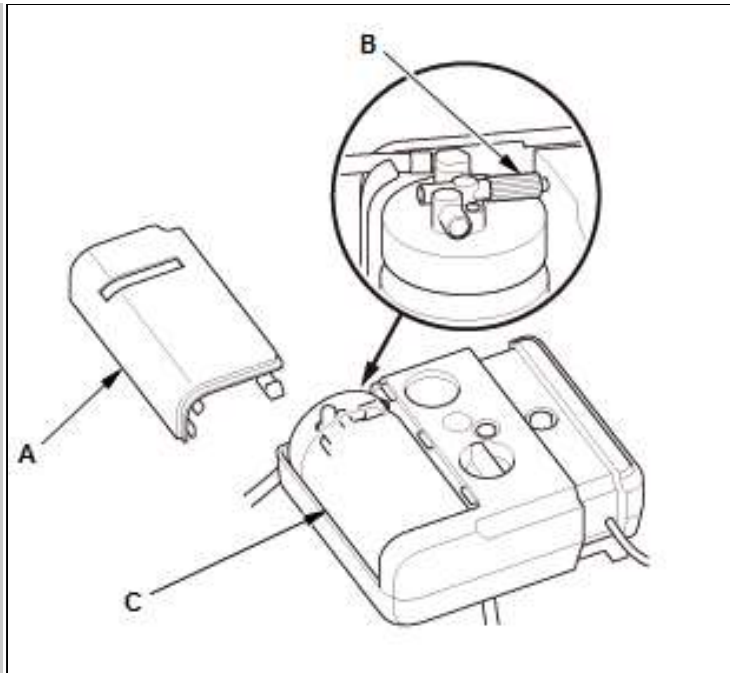

2. Disconnect the joint (B)
3. Remove the tire sealant bottle (C).

Courtesy of HONDA, U.S.A., INC.

2. All Removed Parts - Install

1. Install the all removed parts in the reverse order of removal.

REMOVAL / INSTALLATION > TIRE SEALANT REMOVAL (2016-18) > REMOVAL

NOTE:

- *This procedure is only to be used with the temporary tire repair kit.*
- *The tire inflator and temporary repair sealant are used on vehicles without a spare tire.*
- *The temporary repair sealant used to repair the tire must be removed before the tire is permanently repaired.*
- *The temporary repair sealant (once used or past the expiration date) is considered hazardous waste, and must be disposed of in an environmentally safe manner (such as used engine oil and coolant). Check with your local regulations for proper disposal.*
- *The expiration date of the temporary repair sealant is printed on the container.*

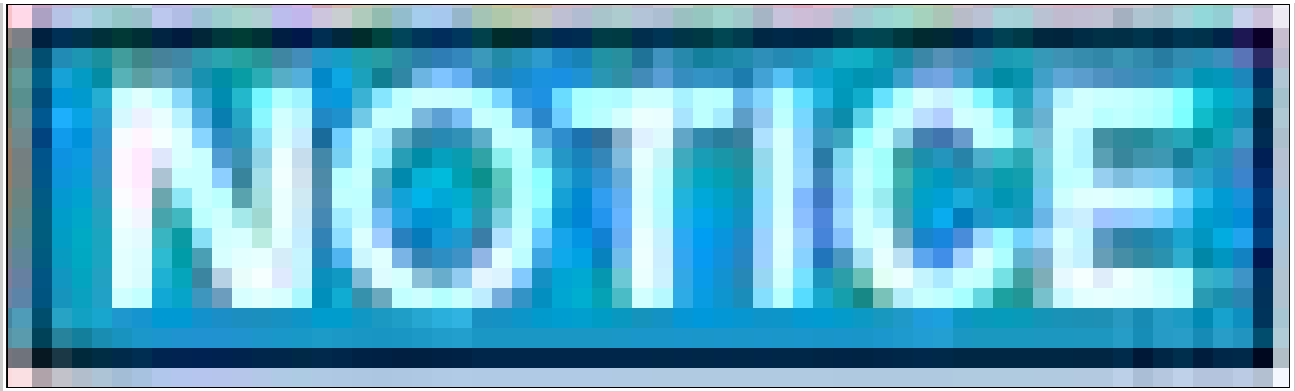

Courtesy of HONDA, U.S.A., INC.

Do not dispose of a tire still filled with sealant.

1. Vehicle - Lift
2. Wheel - Remove
3. Tire Sealant - Remove

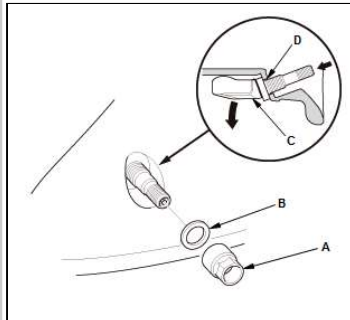

Courtesy of HONDA, U.S.A., INC.

1. Deflate the tire
2. Place the wheel and tire assembly upright with the tire valve stem at the 6 o'clock position
3. Remove the valve stem nut (A)
4. Remove the washer (B)
5. Push the tire pressure sensor (C) into the wheel, down into the tire.

 **NOTE:**

1. Be careful not to spill the tire sealant from the valve stem hole (D).
2. Check the nut and the washer, if they have deterioration or damage, replace them with new ones during reassembly.

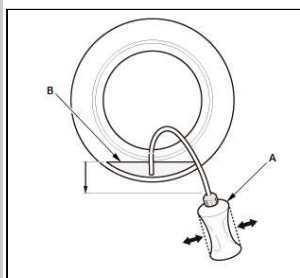

Courtesy of HONDA, U.S.A.,
INC.

6. Use a commercially available squeeze bottle (A), a siphon gun, or a hand vacuum tool with a proper tube to remove the tire sealant
7. Insert the tube into the tire through the valve stem hole, and stick it down until the end of the tube is immersed into the sealant (B)
8. Remove the tire sealant.

 **NOTE:** *If using the bottle with the tube, set the bottle in a lower position than the tire and squeeze the bottle to siphon the tire sealant into the bottle*

9. Completely seal and dispose of the bottle containing the tire sealant in the proper manner for hazardous waste. Check with your local regulations.

4. Tire Pressure Sensor and Resonator - Clean

1. Remove the tire from the wheel.
2. Remove the tire pressure sensor (A) and the valve seal (B) from inside the tire.
3. Completely rinse the tire pressure sensor with cold water to remove the tire sealant.



NOTE: Do not use any soap or cleaner. Use cold water only. Make sure there is no tire sealant stuck to the sensor. If the sealant has dried onto the tire pressure sensor, then the sensor must be replaced .

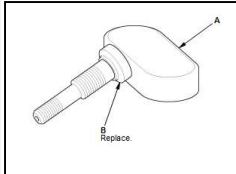

Courtesy of HONDA,
U.S.A., INC.

4. If you are repairing the tire for reuse, completely wipe the inside of the tire, fix the flat, and reinstall the tire pressure sensor with a new valve seal .



NOTE:

1. Wipe the fluid sealant completely so that the beaded edge of the tire and the mating portion of the wheel rim and the bead are cleared.
2. The damaged portion such as punctures may be filled with the fluid sealant, and can not be found depending on the extent of the damage.

5. Install the tire to the wheel.

5. Wheel - Install

6. Test Drive - Check

1. Test-drive the vehicle at 28 mph (45 km/h) or more for at least 3 minutes.

7. Tire Pressure Sensor - Check

1. Turn the vehicle to the ON mode.
2. Make sure the low tire pressure/TPMS indicator does not come on - Refer to: How to Troubleshoot the TPMS (2016-18), or How to Troubleshoot the Body Electrical (2016-18) .
3. Reduce the pressure in one tire less than low tire pressure warning threshold:

Low Tire Pressure Warning Threshold

Front:	190 kPa (1.94 kgf/cm ² , 27.6 psi)
Rear:	183 kPa (1.87 kgf/cm ² , 26.5 psi)

4. Make sure the low tire pressure/TPMS indicator turns on - Refer to: How to Troubleshoot the TPMS (2016-18), or How to Troubleshoot the Body Electrical (2016-18) . If the low tire pressure/TPMS indicator does not come on, replace the tire pressure sensor .
5. Inflate the tire to the specified tire pressure listed on the doorjamb label.

REMOVAL / INSTALLATION > WHEEL BOLT REMOVAL AND INSTALLATION (2013-18)

Special Tools Required

Image	Description/Tool Number
 <p>A technical drawing of a ball joint remover tool. It consists of a metal head with two curved jaws and a central threaded rod. A braided steel cable is attached to the end of the rod and is coiled.</p>	Ball Joint Remover, 28 mm 07MAC-SL00202
Courtesy of HONDA, U.S.A., INC.	

REMOVAL / INSTALLATION > WHEEL BOLT REMOVAL AND INSTALLATION (2013-18) > REMOVAL



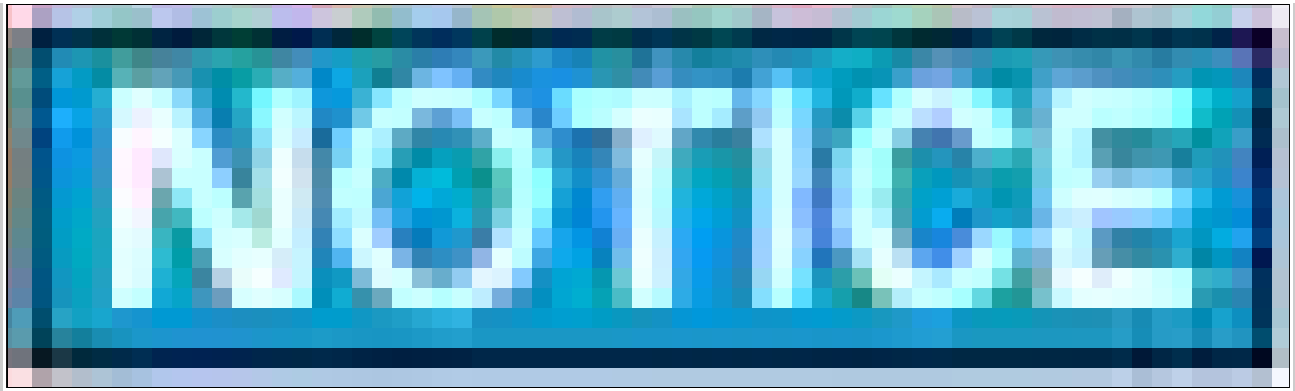

Courtesy of HONDA, U.S.A., INC.

- Do not use a hammer or impact tools (pneumatic or electric).
- Be careful not to damage the threads of the wheel bolts.

Front

1. Vehicle - Lift

1. Raise and support the vehicle .

2. Wheel - Remove

1. Remove the front wheel .

3. Wheel Hub - Remove

1. Remove the front hub .

4. Wheel Bolt - Remove

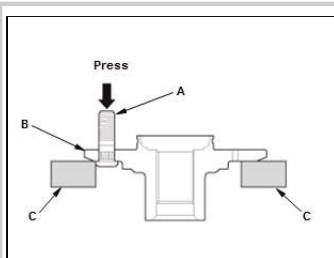

Courtesy of HONDA, U.S.A., INC.

1. Separate the wheel bolt (A) from the hub (B) using a hydraulic press. Support the hub with hydraulic press attachments (C) or equivalent tools.

Rear

5. Vehicle - Lift

1. Raise and support the vehicle .

6. Wheel - Remove

--	--

1. Remove the rear wheel .

7. Brake Disc/Drum - Remove

1. Remove the rear brake disc/drum .

8. Wheel Bolt - Remove

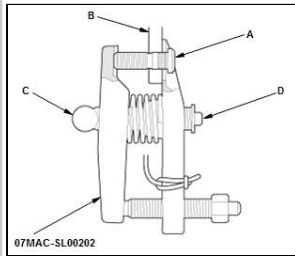

Courtesy of HONDA, U.S.A.,
INC.

1. Separate the wheel bolt (A) from the hub (B).

 **NOTE:** *If the angle of the remover against the wheel bolt is not vertical, readjust the ball joint remover by turning the head (C) of the adjusting bolt (D).*

REMOVAL / INSTALLATION > WHEEL BOLT REMOVAL AND INSTALLATION (2013-18) > INSTALLATION

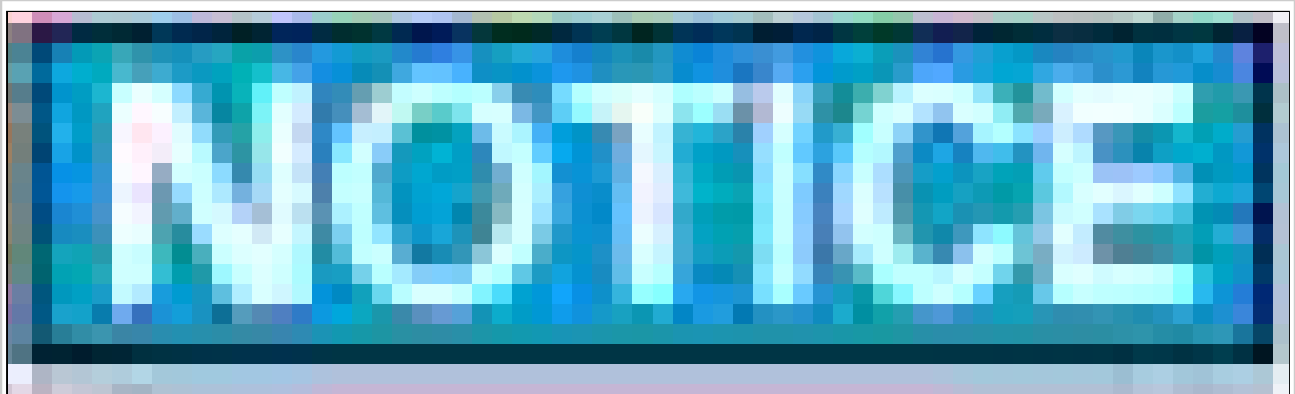

Courtesy of HONDA, U.S.A., INC.

- Do not use a hammer or impact tools (pneumatic or electric).
- Be careful not to damage the threads of the wheel bolts.

Front

1. Wheel Bolt - Install

1. Insert the new wheel bolt (A) into the hub (B) while aligning the splined surfaces (C) on the hub hole with the wheel bolt.

 **NOTE:**

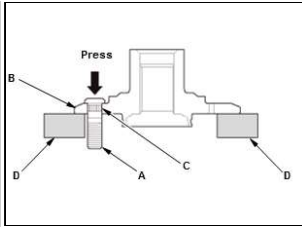

Courtesy of HONDA, U.S.A., INC.

1. Degrease the area around the wheel bolt.
2. Make sure the wheel bolt is installed vertically to the hub disc surface.
3. Before installing the new wheel bolt, clean the mating surfaces on the bolt and the hub.

2. Install the wheel bolt using a hydraulic press until the wheel bolt shoulder is fully seated. Support the hub with hydraulic press attachments (D) or equivalent tools.

2. Wheel Hub - Install

1. Install the front hub .

3. Wheel - Install

1. Install the front wheel .

 **NOTE:** If you cannot tighten the wheel nut to the specified torque when installing the wheel, replace the front hub .

Rear

4. Wheel Bolt - Install

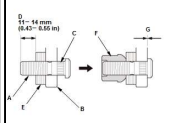

Courtesy of
HONDA, U.S.A.,
INC.

1. Insert the new wheel bolt (A) into the hub (B) while aligning the splined surfaces (C) on the hub hole with the wheel bolt.

 **NOTE:**

1. Before installing the new wheel bolt, clean the mating surfaces on the bolt and the hub.
2. Degrease the area around the wheel bolt and the threaded section of the nut.

2. Adjust the measurement (D) with the washers (P/N 94101-12800 or equivalent) (E)
3. Install a nut (P/N 90304-SC2-000 or equivalent) (F) hand-tight.

 **NOTE:**

1. Make sure the wheel bolt is installed vertically to the hub disc surface.

2. Do not install the nut and the washers that have been used as tools on a vehicle.

4. Tighten the nut.



NOTE:

1. Do not exceed the maximum torque limit.
2. Make sure there is no gap (G) between the bolt and the hub.

Limited torque: 108 N.m (11.0 kgf.m, 80 Inf.ft) max.



NOTE: If you cannot tighten the wheel nut to the specified torque when installing the wheel, replace the rear hub bearing unit as an assembly - Refer to: Rear Knuckle/Hub Bearing Unit Removal and Installation (2013-15), or Rear Knuckle/Hub Bearing Unit Removal and Installation (2016-18).

5. Brake Disc/Drum - Install

1. Install the rear brake disc/drum .

6. Wheel - Install

1. Install the rear wheel .

REMOVAL / INSTALLATION > WHEEL REMOVAL AND INSTALLATION (2013-18) > REMOVAL

1. Vehicle - Lift

1. Raise and support the vehicle .

2. Wheel - Remove

1. Remove the wheel.

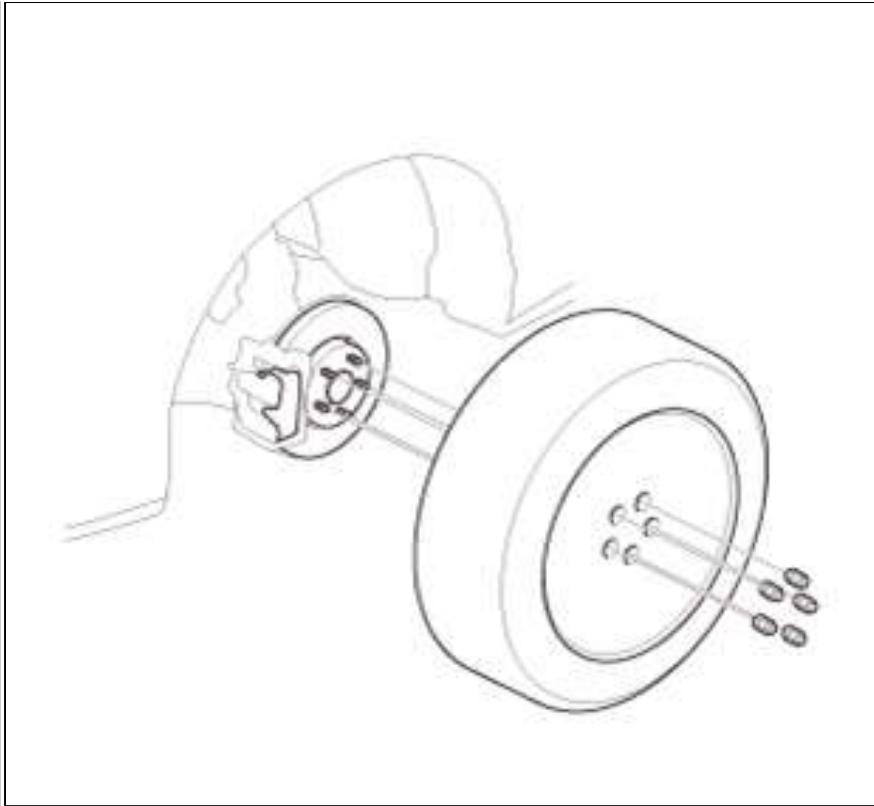

Courtesy of HONDA, U.S.A., INC.

REMOVAL / INSTALLATION > WHEEL REMOVAL AND INSTALLATION (2013-18) > INSTALLATION

1. Wheel - Install

Fig 1: Wheel Nut With Torque Specifications

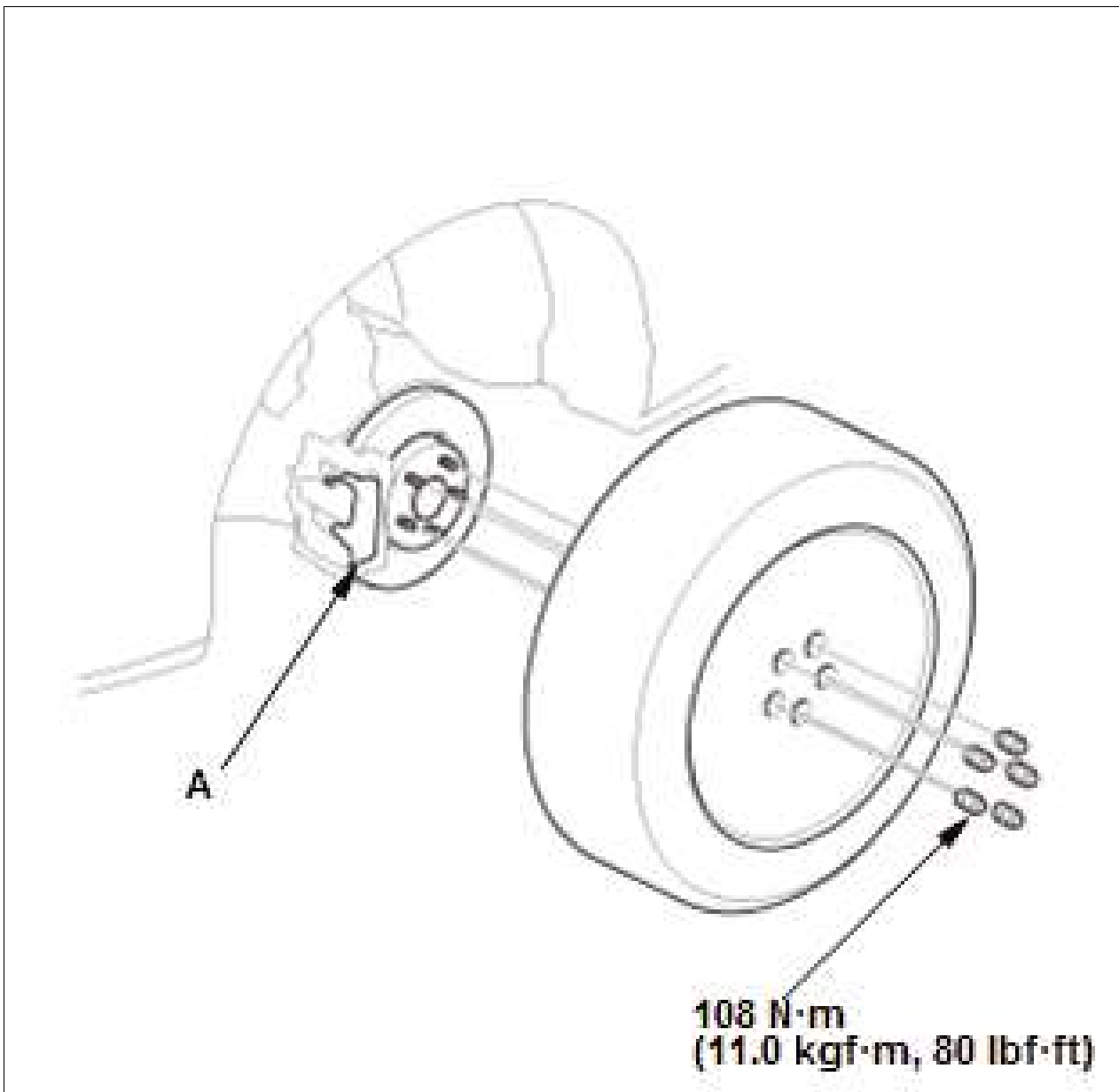

Courtesy of HONDA, U.S.A., INC.

1. Install the wheel.



NOTE:

1. Before installing the wheel, clean the mating surfaces between the brake disc or brake disc/drum and the inside of the wheel.
2. For some model : When installing the front wheel, make sure the wheel does not contact the caliper cover (A).