

**REMOVAL / INSTALLATION > FRONT DAMPER/SPRING REMOVAL AND INSTALLATION  
(2016-18) > REMOVAL**

1. Vehicle - Lift

2. Front Wheel - Remove

3. Damper/Spring Items - Remove

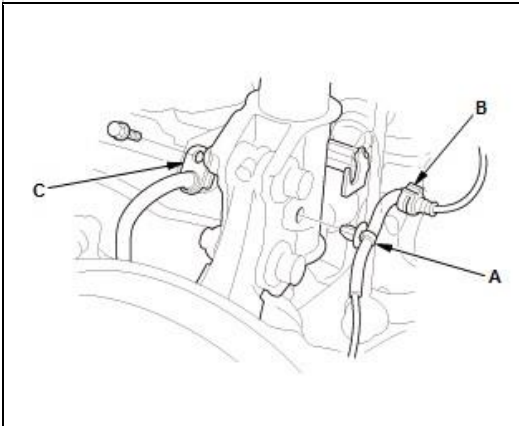

Courtesy of HONDA, U.S.A., INC.

1. Remove the wheel speed sensor harness clip (A) and the wire guide (B).

NOTE: Do not disconnect the wheel speed sensor connector

2. Remove the brake hose bracket (C).

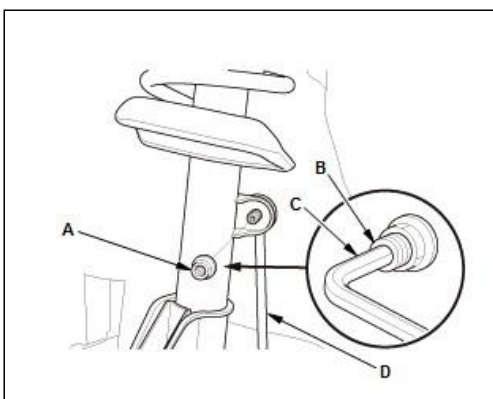

Courtesy of HONDA, U.S.A., INC.

3. Remove the flange nut (A) while holding the joint pin (B ) with a hex wrench (C)

4. Disconnect the stabilizer link (D) from the damper.

4. Damper/Spring - Remove

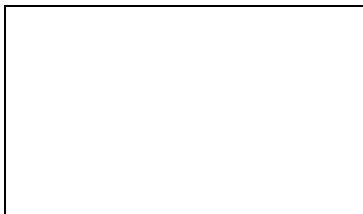

NOTE: Do not allow the knuckle to rotate too far outward. This may allow the driveshaft inboard joint to come apart.

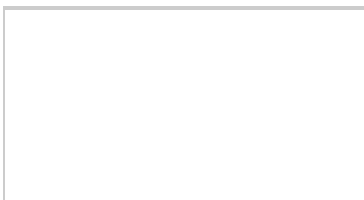

1. Remove the damper pinch bolts (A) and the flange nuts (B).

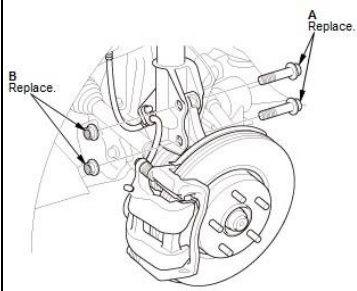

Courtesy of HONDA, U.S.A., INC.

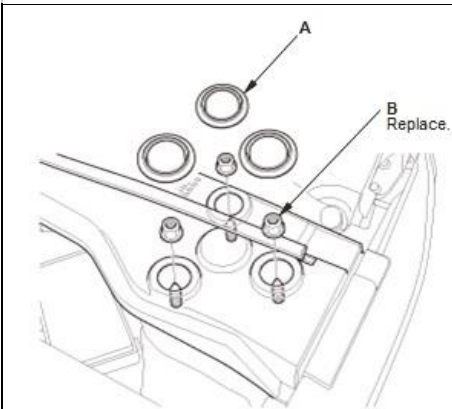

Courtesy of HONDA, U.S.A., INC.

2. Remove the service caps (A)
3. Remove the flange nuts (B).

NOTE: Do not let the damper/spring drop down under its own weight.

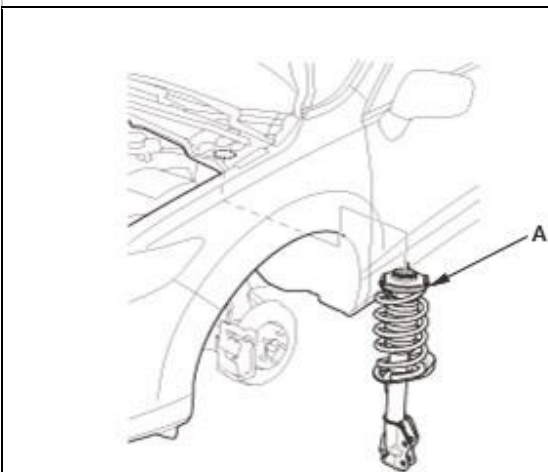

Courtesy of HONDA, U.S.A., INC.

4. Remove the damper/spring (A).

NOTE: Be careful not to damage the body.

**REMOVAL / INSTALLATION > FRONT DAMPER/SPRING REMOVAL AND INSTALLATION**

## (2016-18) > INSTALLATION

### 1. Damper/Spring - Install

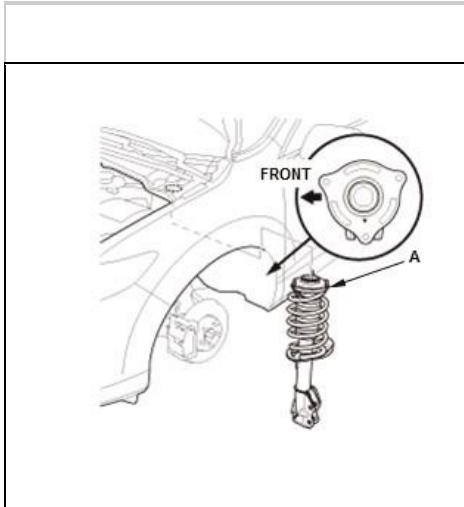

1. Install the damper/spring (A). Note the direction of the damper mounting base as shown.

NOTE: Be careful not to damage the body.

Courtesy of HONDA, U.S.A., INC.

Fig 1: Flange Nuts With Torque Specifications

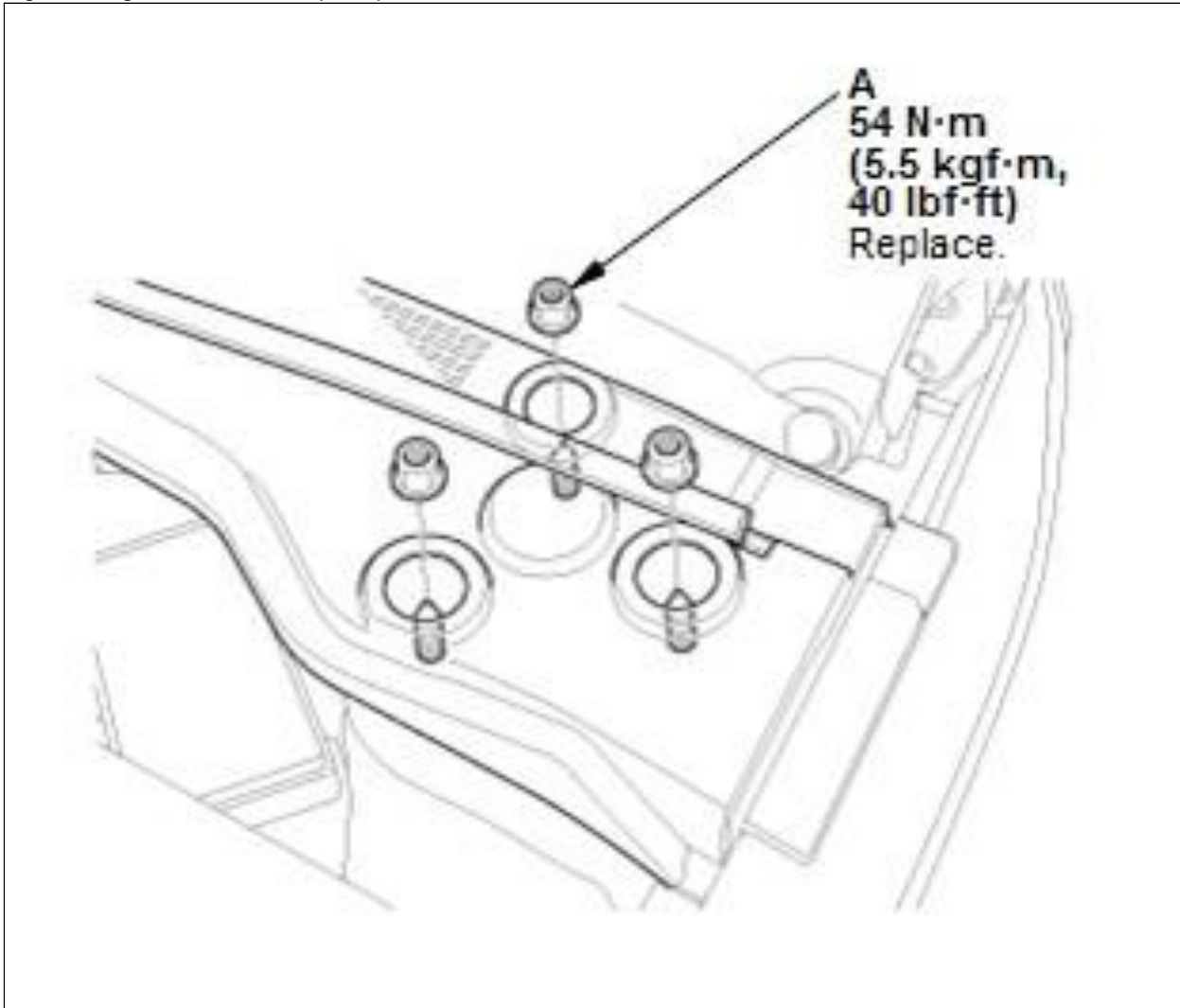

Courtesy of HONDA, U.S.A., INC.

2. Loosely install the new (A).

Fig 2: Damper Pinch Bolts With Torque Specifications

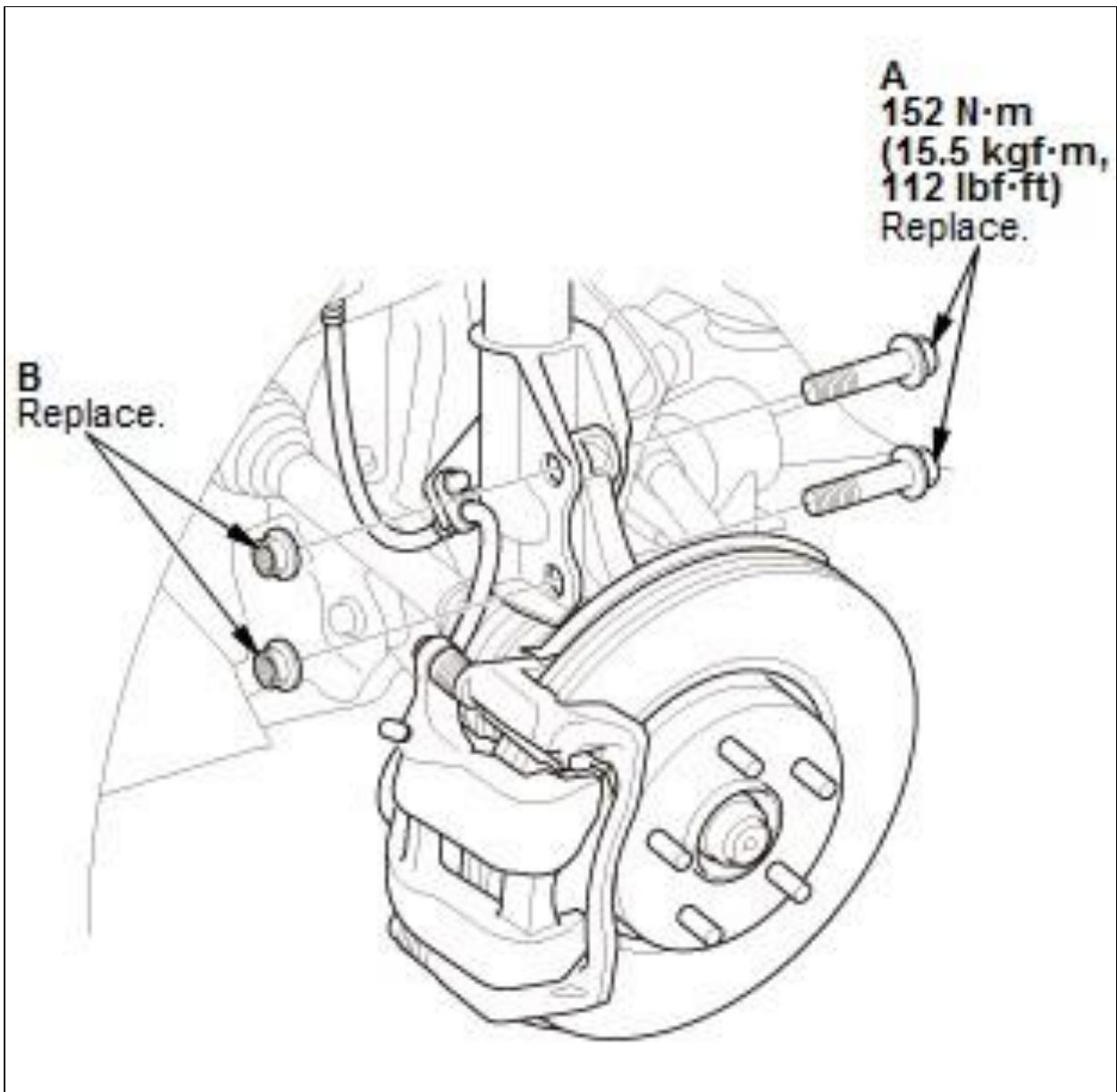

Courtesy of HONDA, U.S.A., INC.

3. Loosely install the new damper pinch bolts (A) and the new flange nuts (B)
  4. Raise the front suspension with a floor jack to load the suspension with the vehicle's weight
  5. Tighten the flange nuts on the upper side of the damper
  6. Tighten the damper pinch bolts while holding the flange nuts on the lower side of the damper.
2. Damper/Spring Items - Install

Fig 3: Stabilizer Link With Torque Specifications

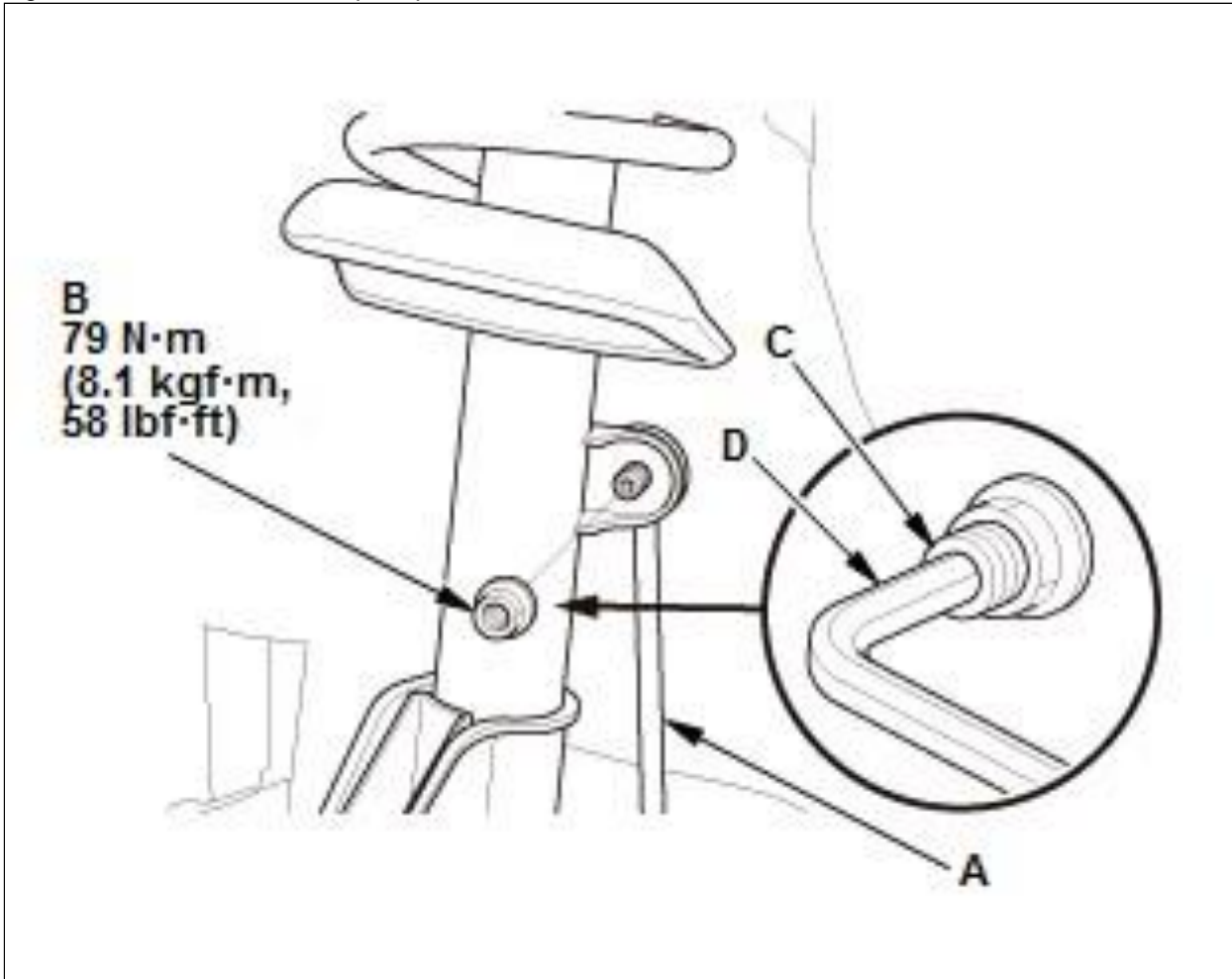

Courtesy of HONDA, U.S.A., INC.

1. Connect the stabilizer link (A) to the damper
2. Tighten the flange nut (B) while holding the joint pin (C) with a hex wrench (D).

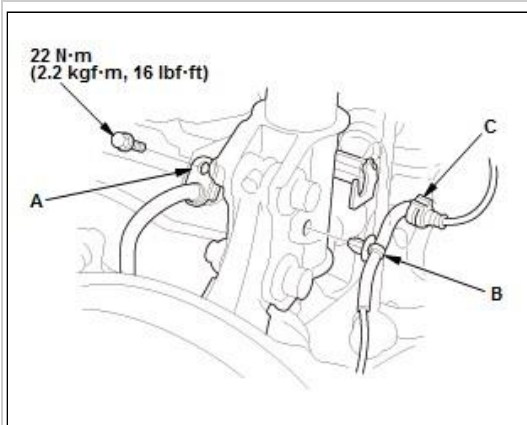

3. Install the brake hose bracket (A)
4. Install the wheel speed sensor harness clip (B) and the wire guide (C).

Courtesy of HONDA, U.S.A., INC.

5. Install the service caps (A).

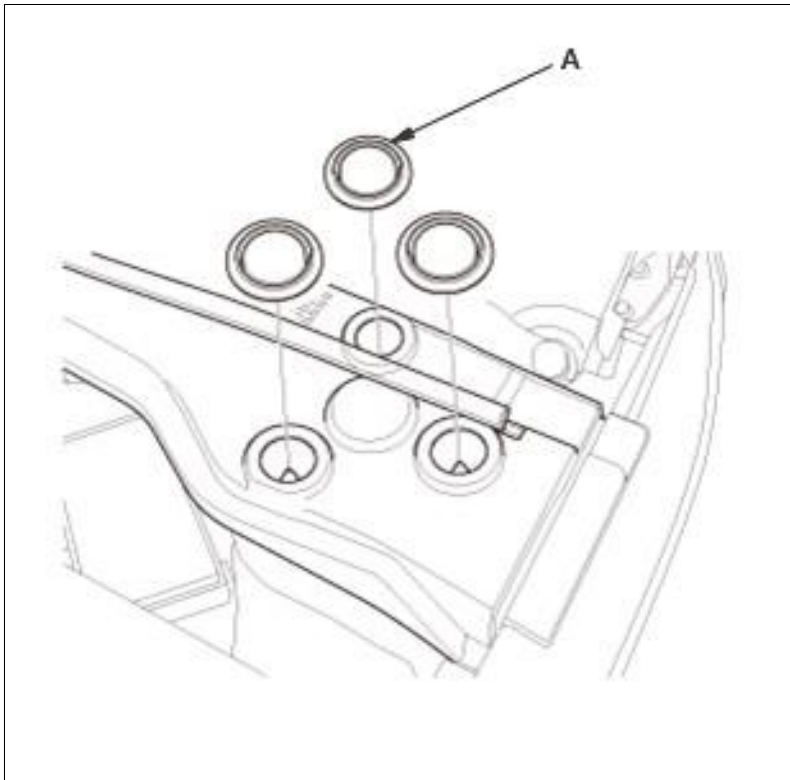

Courtesy of HONDA, U.S.A., INC.

3. Front Wheel - Install 4. Wheel Alignment - Check