

Conventional Brake System Bleeding (2013-18)

Bleeding



Courtesy of HONDA, U.S.A., INC.

Do not spill brake fluid on the vehicle; it may damage the paint. If brake fluid does contact the paint, wash it off immediately with water.

NOTE:

- Do not reuse the drained brake fluid. Use only new Acura DOT 3 Brake Fluid from an unopened container. Using a non-Acura brake fluid can cause corrosion and shorten the life of the system.
 - Make sure no dirt or other foreign matter gets in the brake fluid.
 - The reservoir connected to the master cylinder must be at the MAX (upper) level mark at the start of the bleeding procedure and checked after bleeding each wheel. Add fluid as required.
- There are three different methods used for bleeding brake systems. The method shown here is the preferred manual method for removing the air from the system. For pressure or vacuum bleeding, refer to tool manufacturer's instructions included with the tool.

1. Vehicle - Lift

1. Raise and support the vehicle .

2. Brake System - Bleed

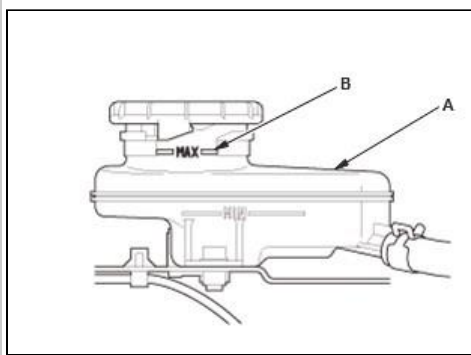

1. Make sure the brake fluid level in subreservoir (A) is at the MAX (upper) level line (B).

Courtesy of HONDA, U.S.A., INC.

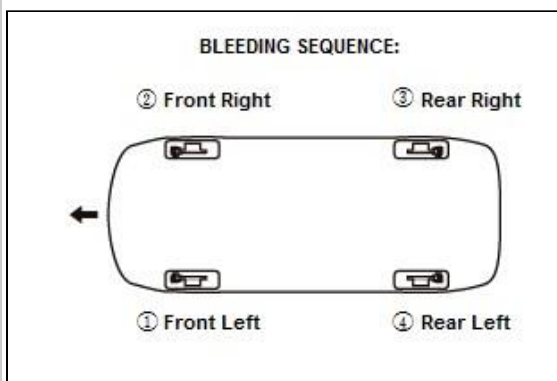

2. Start the bleeding at the driver's side of the front brake system.

NOTE: Bleed the calipers in the sequence shown.

Courtesy of HONDA, U.S.A., INC.

Front

3. Attach a length of clear drain tube (A) to the bleed screw(B)
4. Submerge the other end of the drain tube into a clearplastic catch bottle of brake fluid (C)
5. Have an assistant slowly pump the brake pedal severaltimes then apply steady continuous pressure
6. Loosen the bleed screw slowly to bleed the fluid into theplastic catch bottle. The brake pedal will travel toward the floor as the fluid is bled from the system
7. When the brake pedal reaches the floor, have theassistant hold the pedal in that position, then tighten the bleed screw. The brake pedal can now be released
8. Check and refill the master cylinder reservoir tank to theMAX (upper) level line. Be sure to reinstall the master cylinder reservoir cap
9. Repeat steps 5 thru 8 until the brake fluid in the cleardrain tube appears fresh and there are no air bubbles in the fluid
10. Repeat this procedure for each brake in the bleedingsequence.

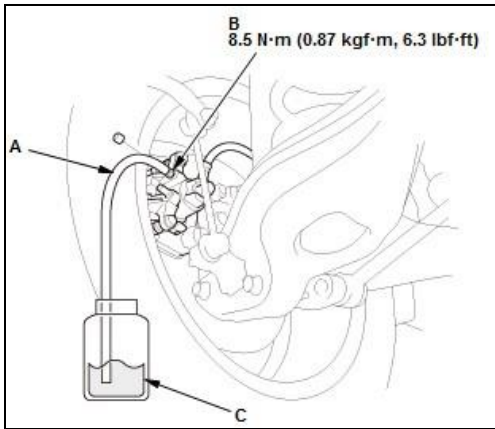
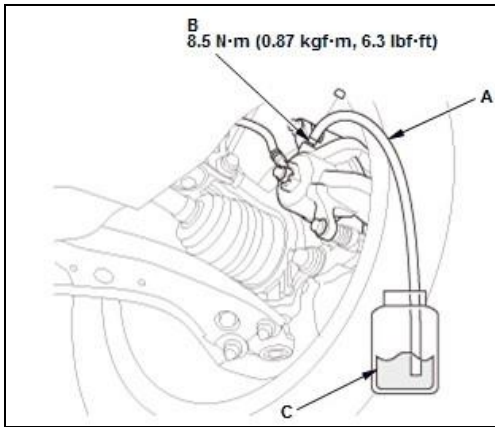

Courtesy of HONDA, U.S.A., INC. HONDA, U.S.A., INC.

Rear

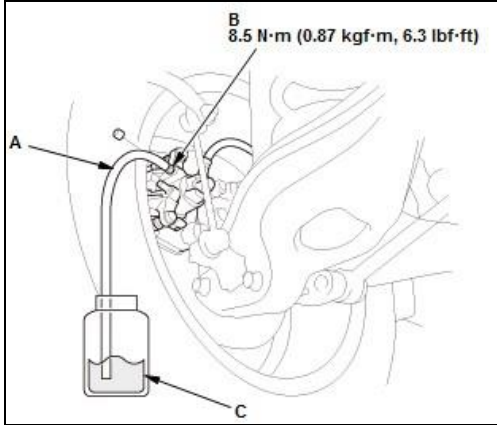
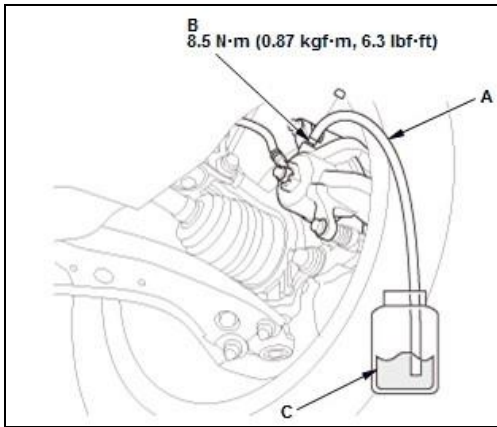

Courtesy of HONDA, U.S.A., INC. HONDA, U.S.A., INC.