

Timing Belt Removal And Installation (2016-18)

Removal

1. Right Front Wheel - Remove
2. Engine Undercover - Remove
3. No. 1 Piston at Top Dead Center - Set (Crank Side)

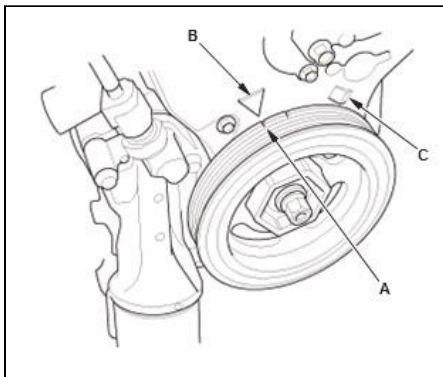

1. Turn the crankshaft so its white mark (A) on the crankshaft pulley lines up with the pointer (B).

NOTE: The other pointer (C) is not used.

Courtesy of HONDA, U.S.A., INC.

4. No. 1 Piston at Top Dead Center - Set (Cam Side)

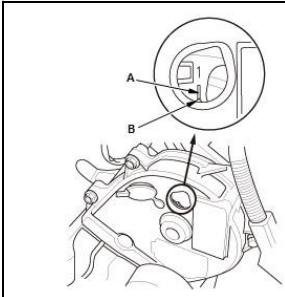

1. Check that the No. 1 piston top dead center (TDC) mark (A) on the front camshaft pulley and the pointer (B) on the front upper covers are aligned.

NOTE: If the marks are not aligned, rotate the crankshaft 360 degrees, and recheck the camshaft pulley mark.

Courtesy of HONDA, U.S.A., INC.

5. Drive Belt Auto-Tensioner - Remove
6. Crankshaft Pulley - Remove
7. Engine - Support
8. Upper Half of Side Engine Mount Bracket - Remove
9. Upper Cover - Remove

1. Lift and support the engine with a jack and a wood block under the oil pan.

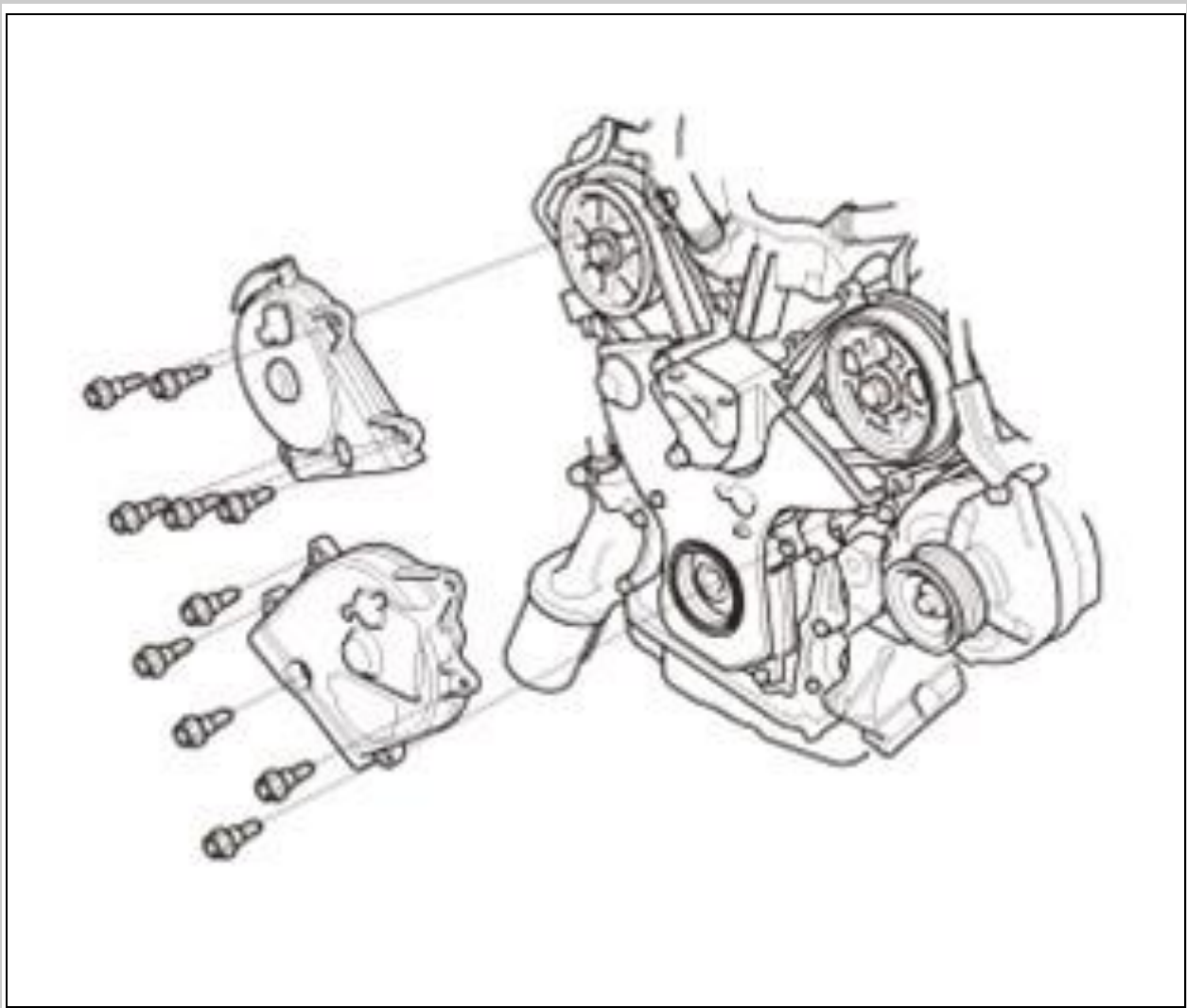

Courtesy of HONDA, U.S.A., INC.

10. Lower Cover - Remove

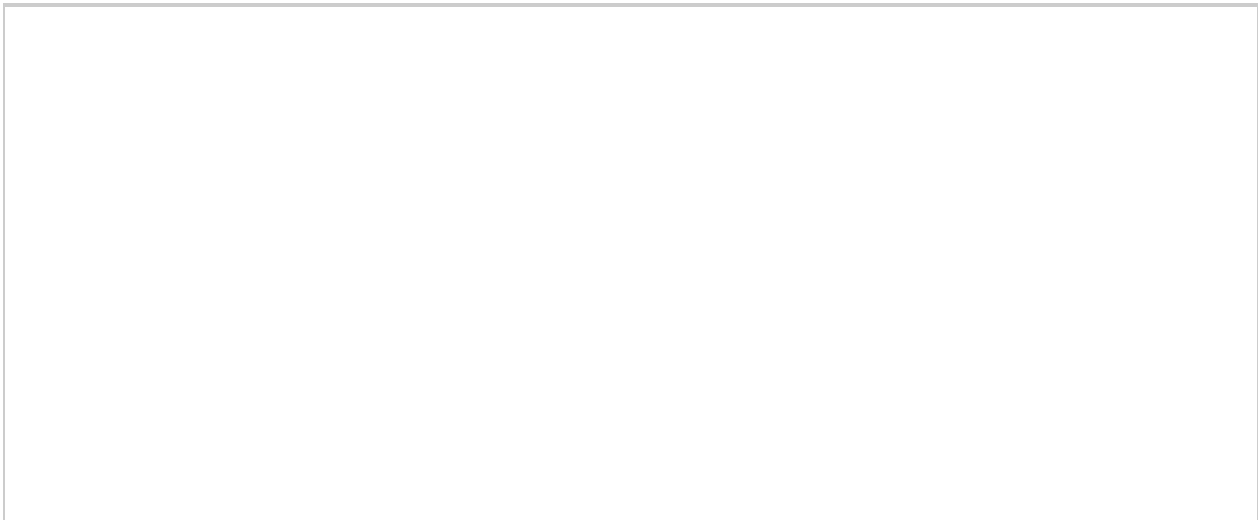

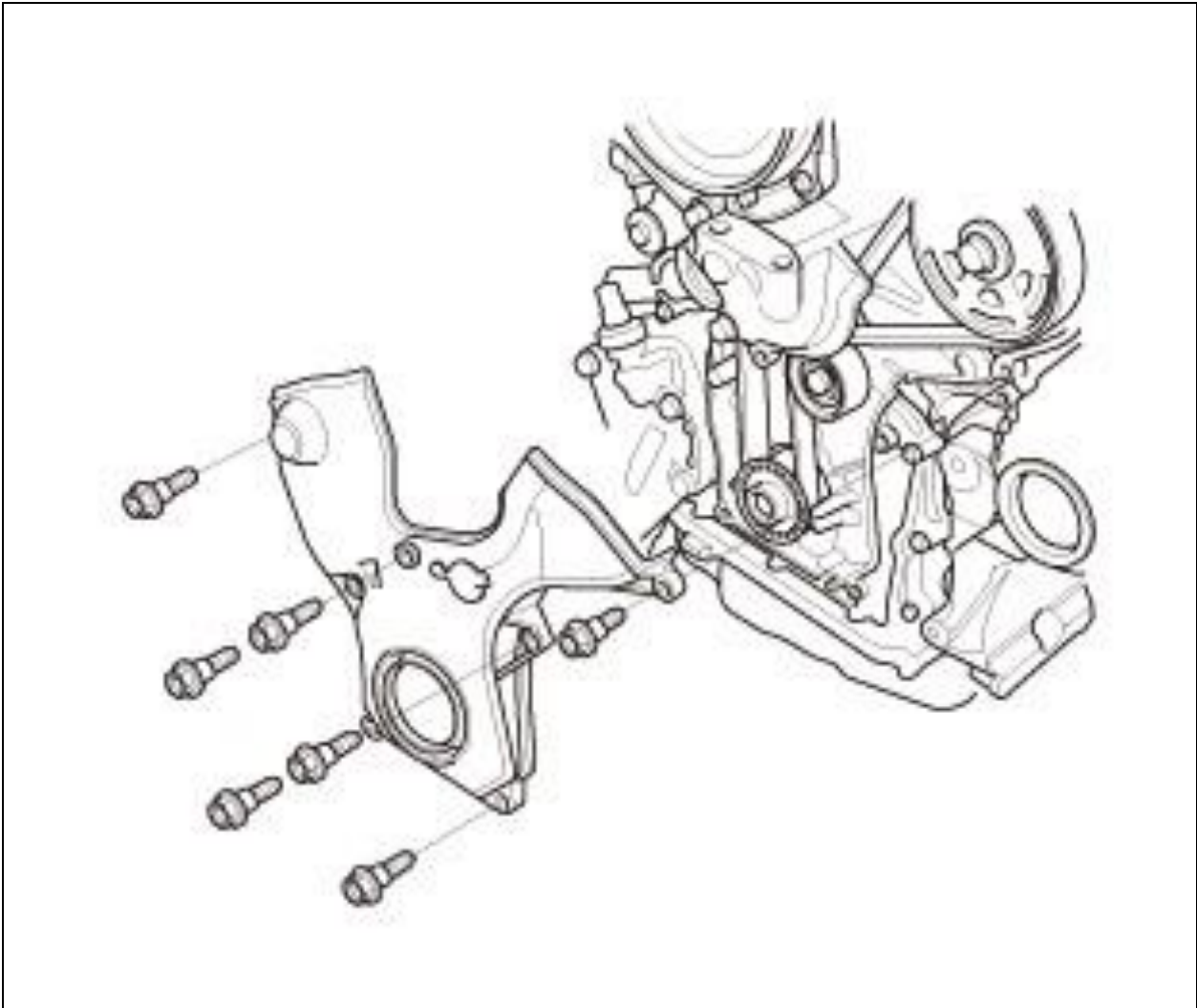

Courtesy of HONDA, U.S.A., INC.

11. Timing Belt Adjuster - Hold

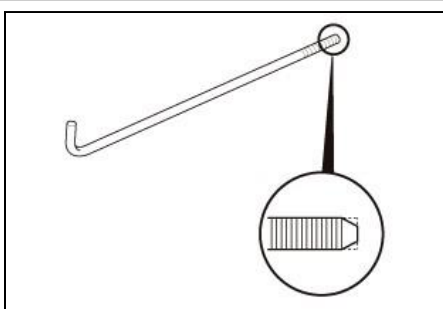

Courtesy of HONDA, U.S.A., INC.

1. Remove one of the battery clamp bolts from the battery tray, and grind the end of it as shown.

2. Thread the battery clamp bolt in as shown to hold the timing belt adjuster in its current position. Tighten it by hand, do not use a wrench.

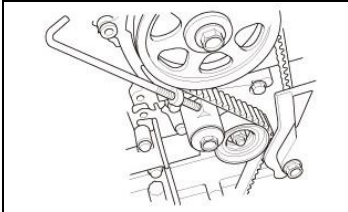

Courtesy of HONDA, U.S.A., INC.

12. Timing Belt Guide Plate - Remove

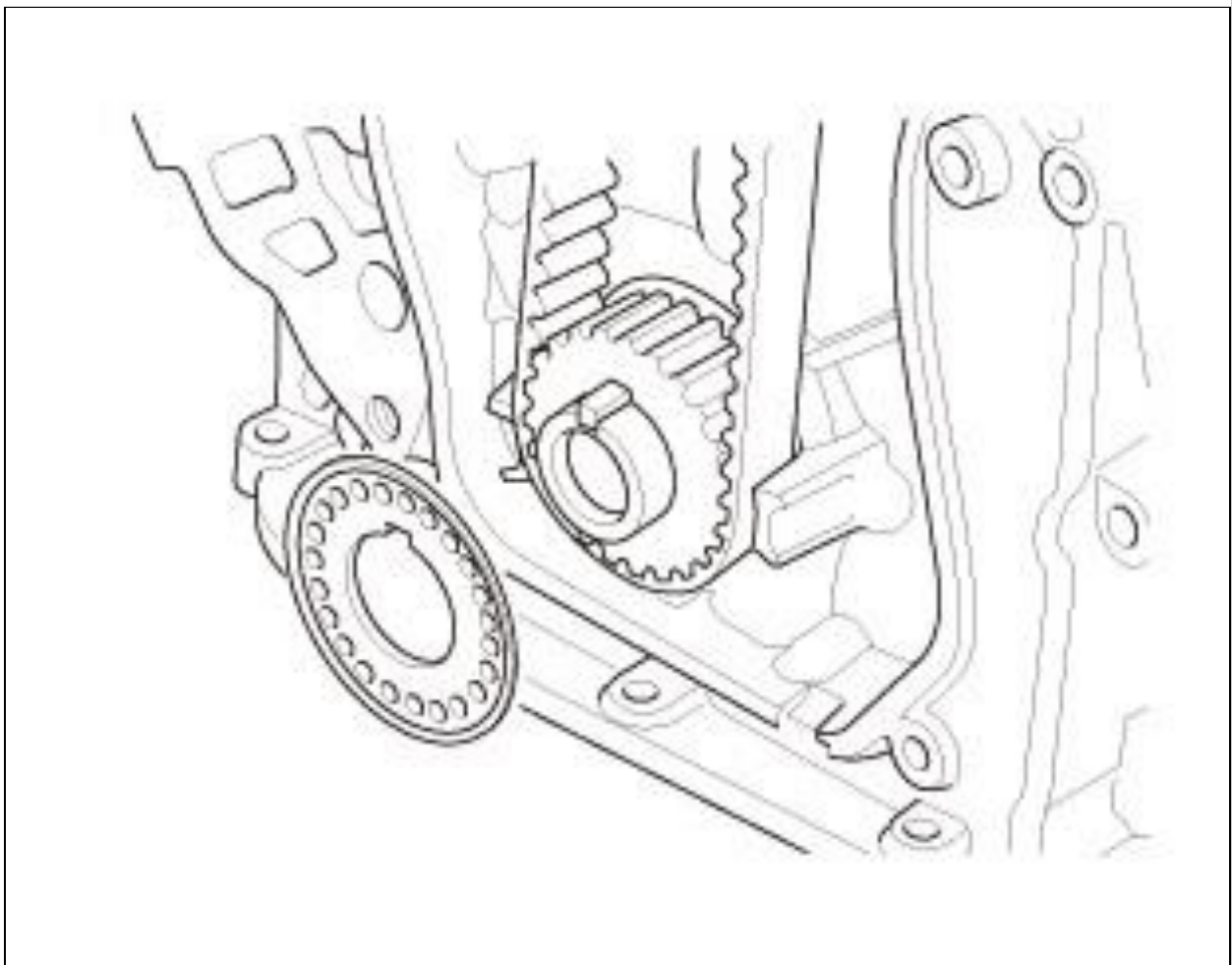

Courtesy of HONDA, U.S.A., INC.

13. Lower Half of Side Engine Mount Bracket - Remove



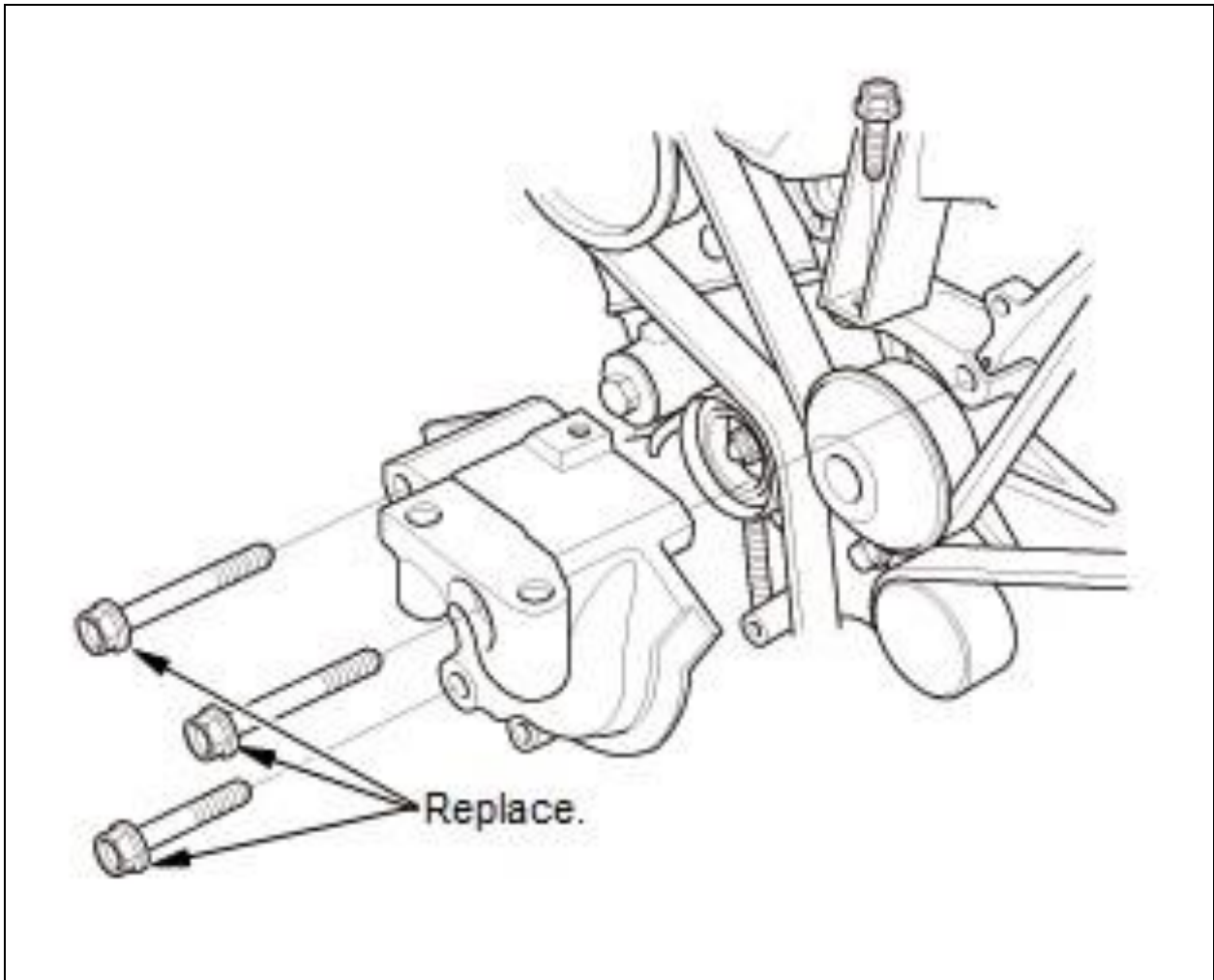

Courtesy of HONDA, U.S.A., INC.

14. Timing Belt - Remove

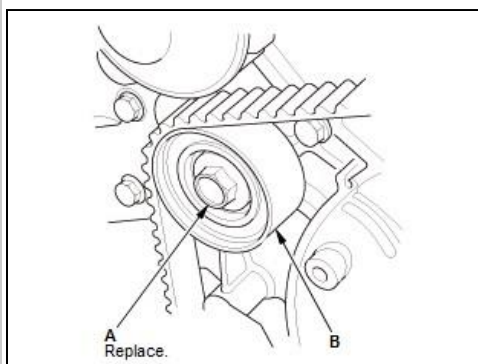

Courtesy of HONDA, U.S.A., INC.

1. Remove the idler pulley bolt (A) and the idler pulley (B). Discard the idler pulley bolt
2. Remove the timing belt.

Installation

NOTE:

- The following procedure is for installation of a used timing belt. If you are installing a new timing belt, refer to the timing belt auto-tensioner installation procedure.
- Clean the timing belt pulleys, the timing belt guide plate, and the upper and lower covers.

1. No. 1 Piston at Top Dead Center - Set (Crank Side)

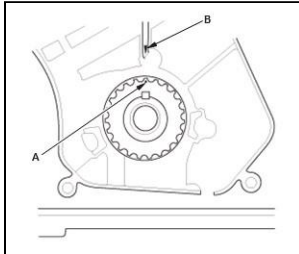

1. Set the timing belt drive pulley to top dead center (TDC) by aligning the TDC mark (A) on the tooth of the timing belt drive pulley with the pointer (B) on the oil pump.

Courtesy of HONDA, U.S.A.,
INC.

2. No. 1 Piston at Top Dead Center - Set (Cam Side)

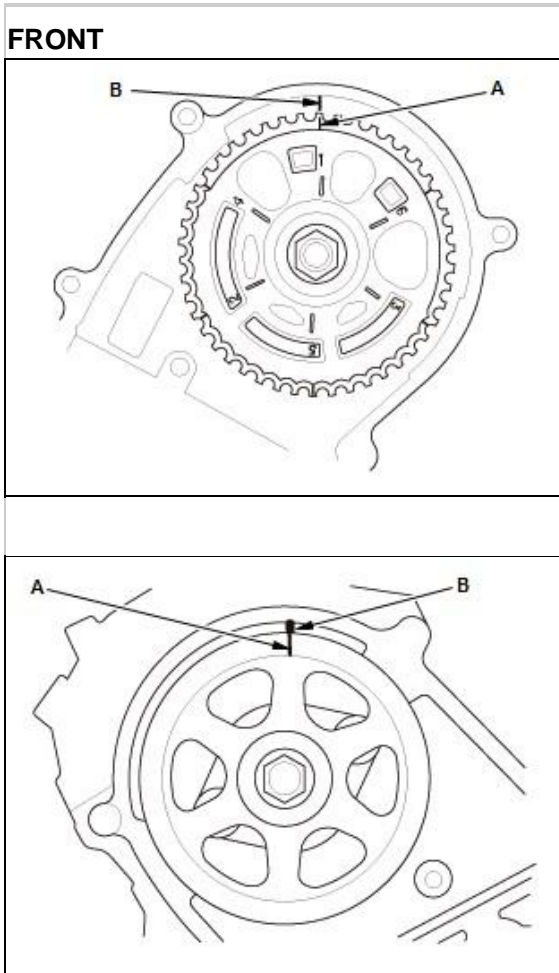

1. Set the camshaft pulleys to TDC by aligning the TDC marks (A) on the camshaft pulleys with the pointers (B) on the back covers.

Courtesy of HONDA, U.S.A., INC.HONDA, U.S.A., INC.

REAR

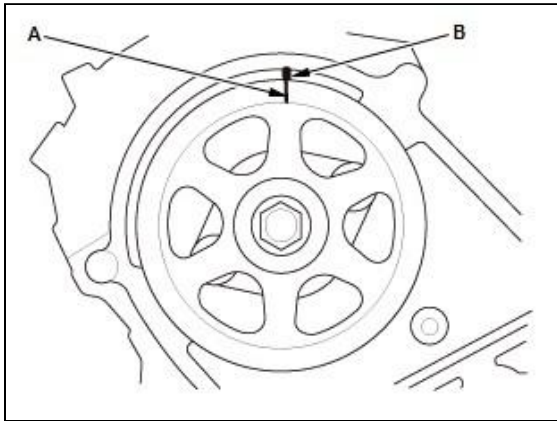
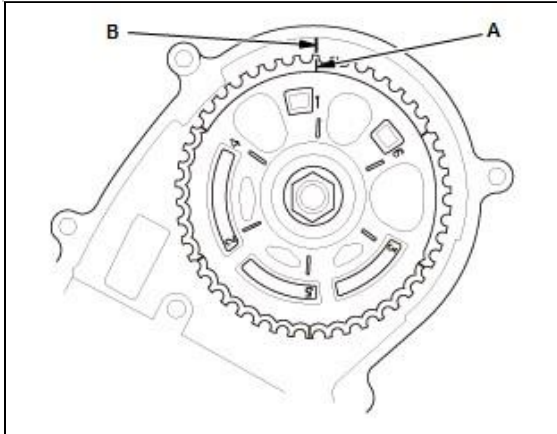

Courtesy of HONDA, U.S.A., INC.HONDA, U.S.A., INC.

3. Idler Pulley - Loosely Install

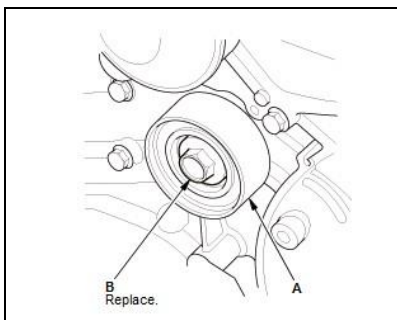

Courtesy of HONDA, U.S.A., INC.

1. Loosely install the idler pulley (A) with a new idler pulley bolt (B) so the pulley can move but does not come off.

4. Timing Belt - Install

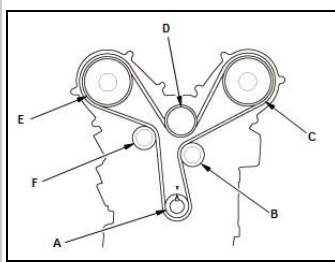

Courtesy of HONDA, U.S.A., INC.

1. If the timing belt auto-tensioner has extended and the timing belt cannot be installed, do the timing belt auto-tensioner installation procedure .
2. Install the timing belt in a counterclockwise sequence starting with the drive pulley. Take care not to damage the timing belt during installation:

1. Drive pulley (A)
2. Idler pulley (B)
3. Front camshaft pulley (C)
4. Water pump pulley (D)
5. Rear camshaft pulley (E)
6. Adjusting pulley (F)

5. Idler Pulley Bolt - Tighten

Fig 1: Idler Pulley Bolt With Torque Specifications

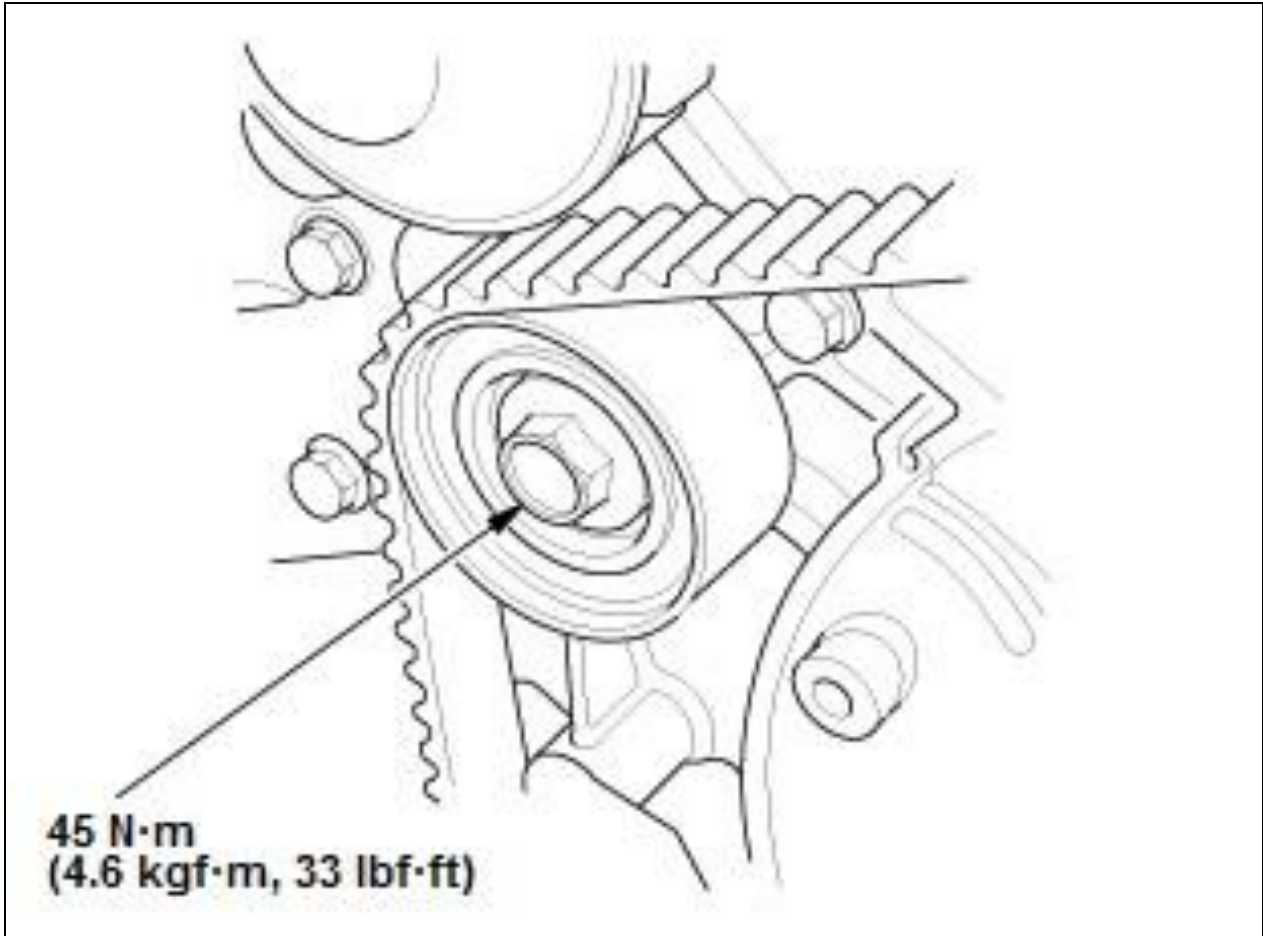

Courtesy of HONDA, U.S.A., INC.

6. Battery Clamp Bolt - Remove

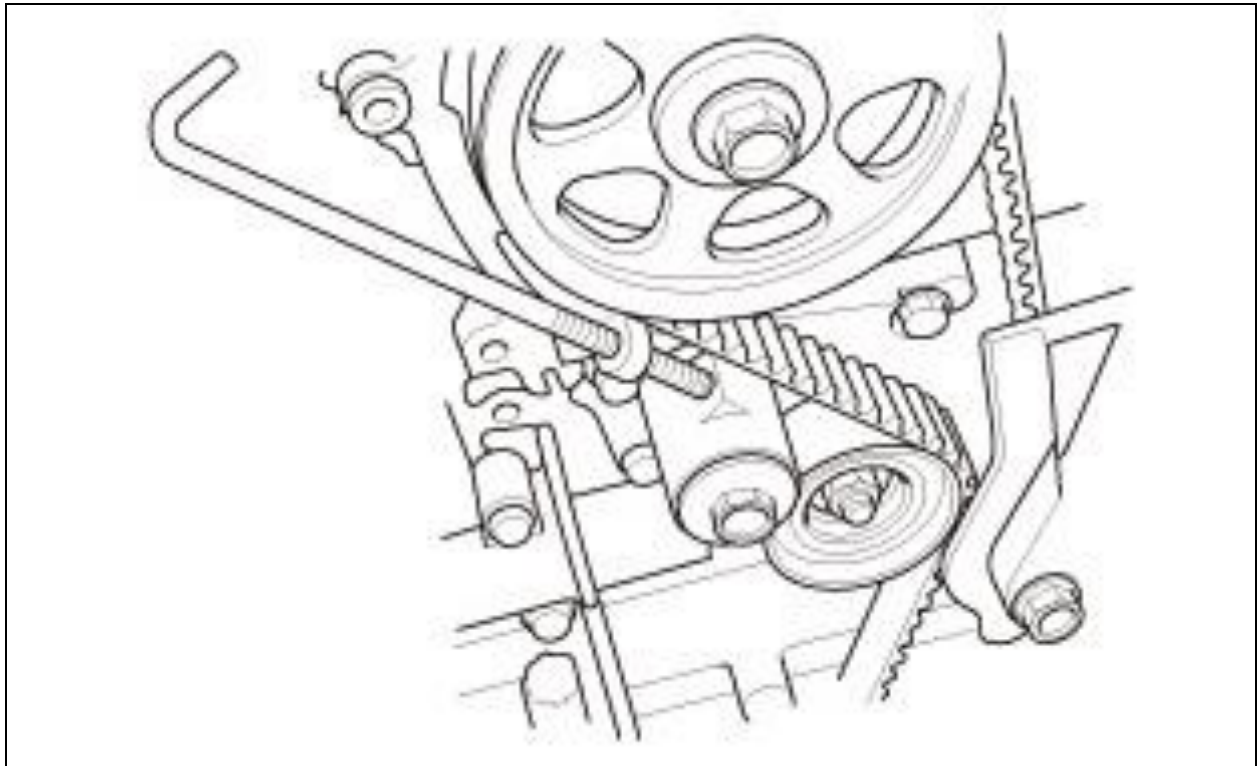

Courtesy of HONDA, U.S.A., INC.

7. Lower Half of Side Engine Mount Bracket - Install

Fig 2: Lower Half of Side Engine Mount Bracket With Torque Specifications

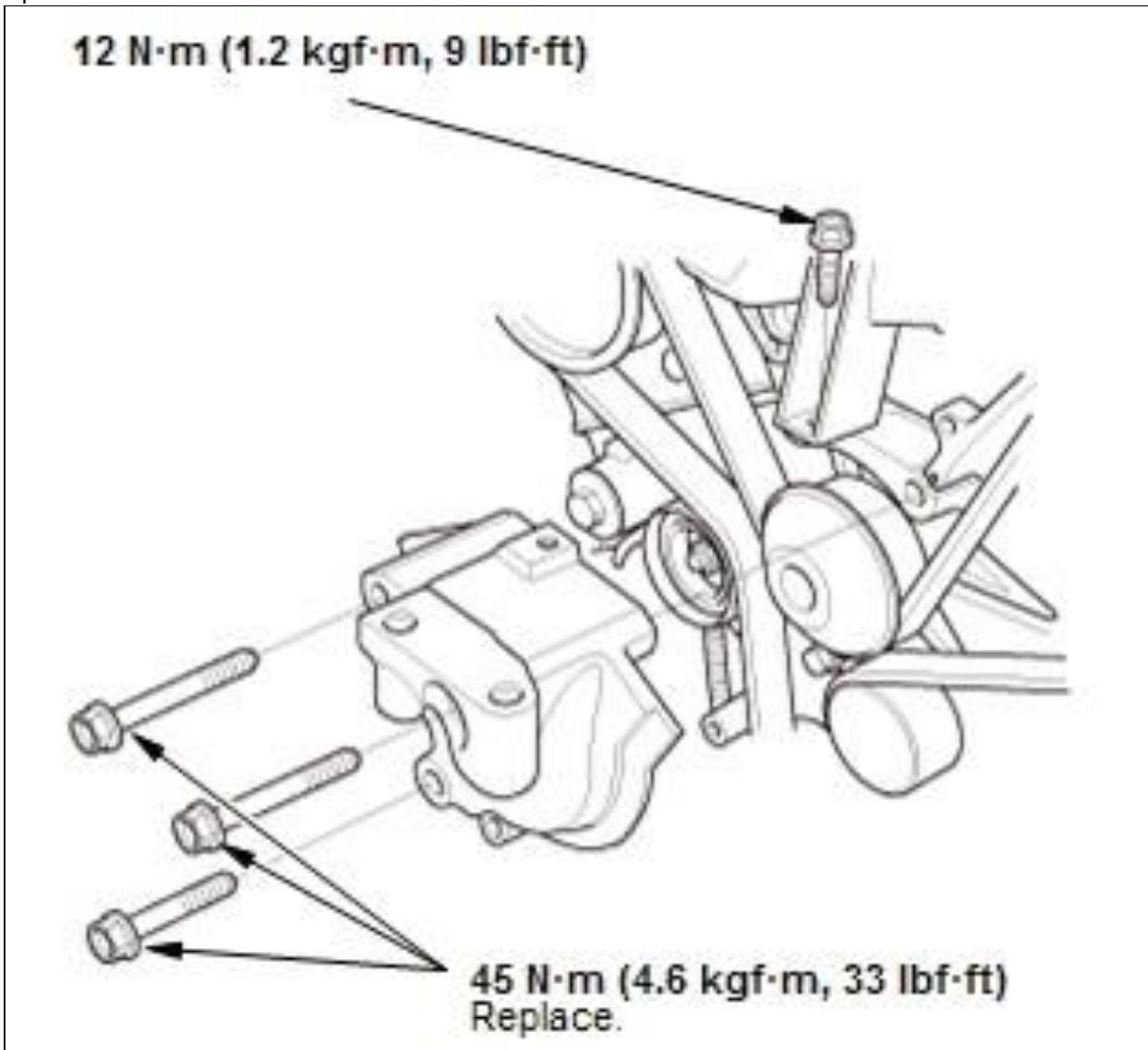

Courtesy of HONDA, U.S.A., INC.

8. Timing Belt Guide Plate - Install

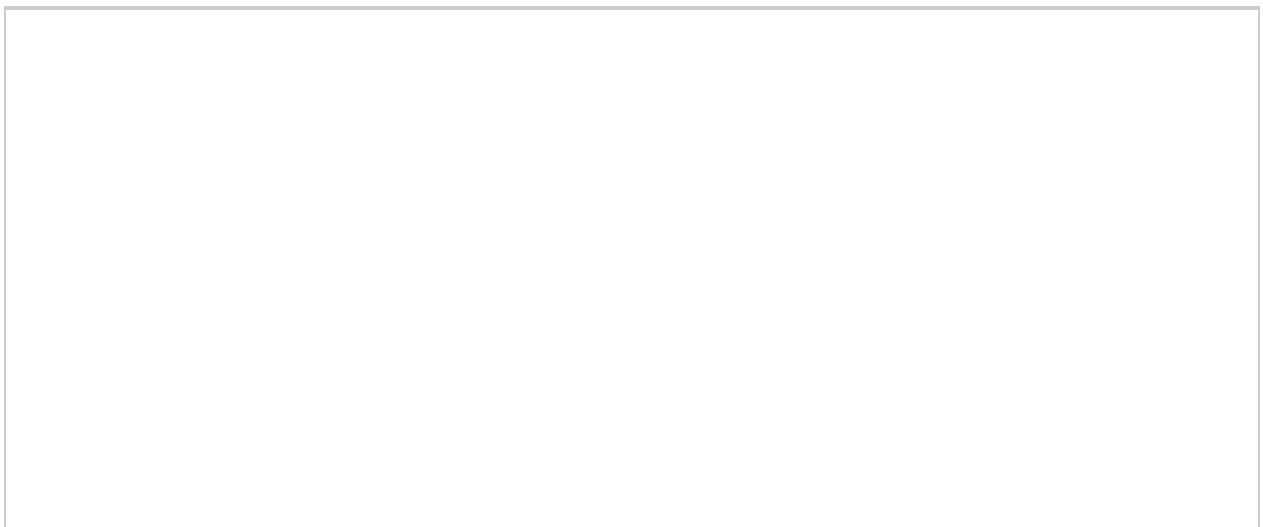

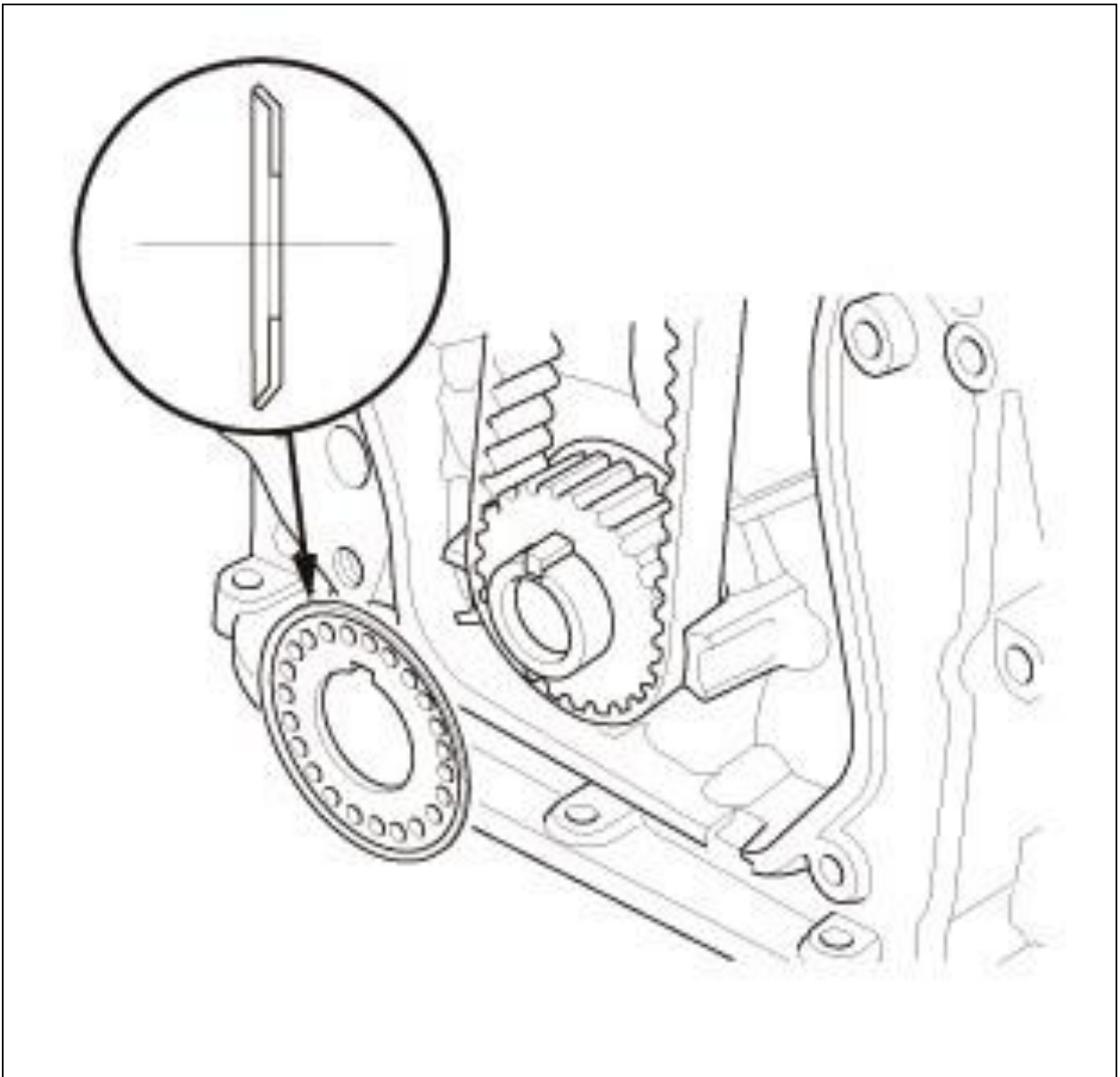

Courtesy of HONDA, U.S.A., INC.

9. Lower Cover - Install

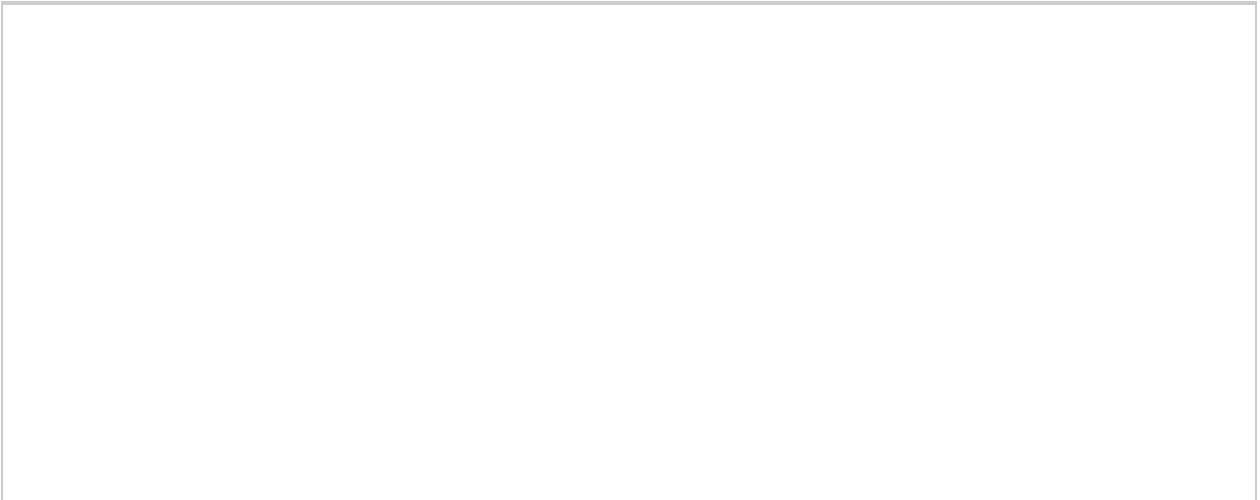

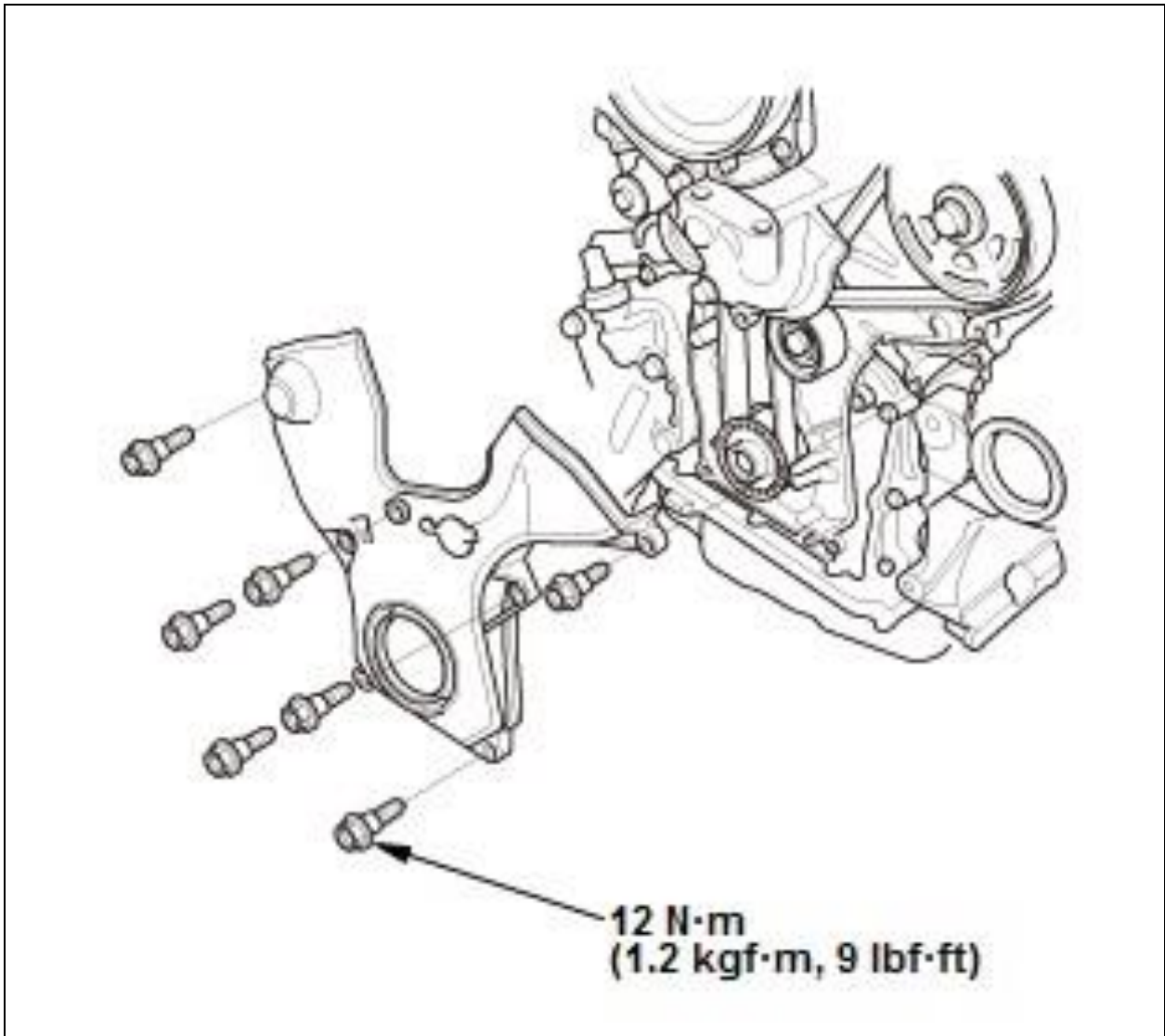

Courtesy of HONDA, U.S.A., INC.

10. Upper Cover - Install

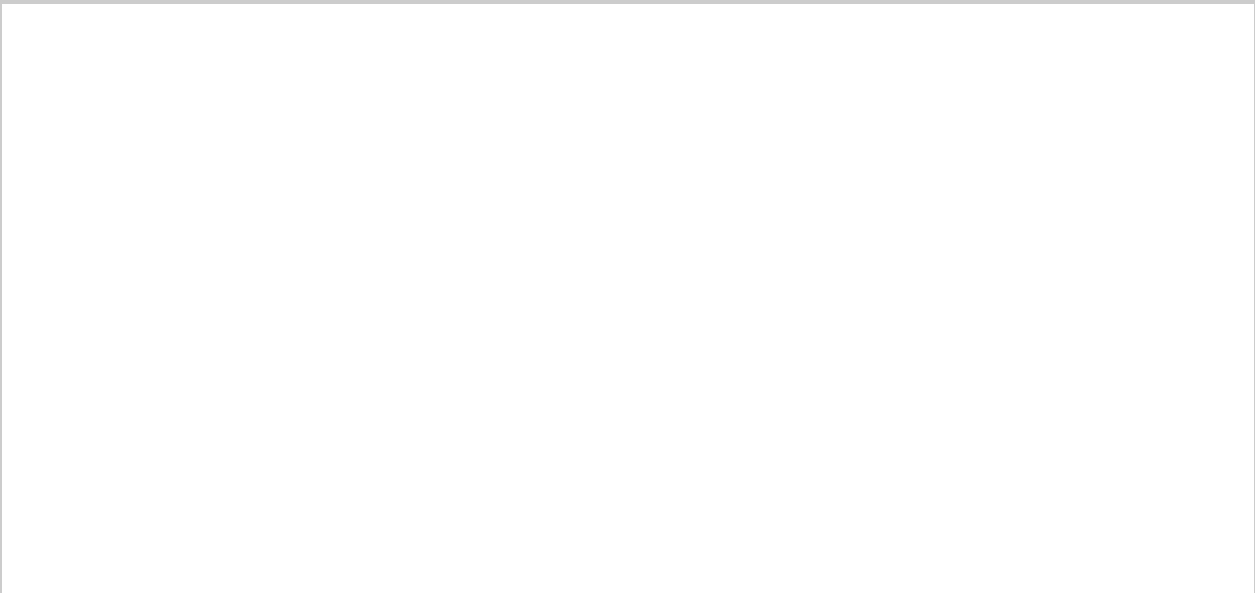

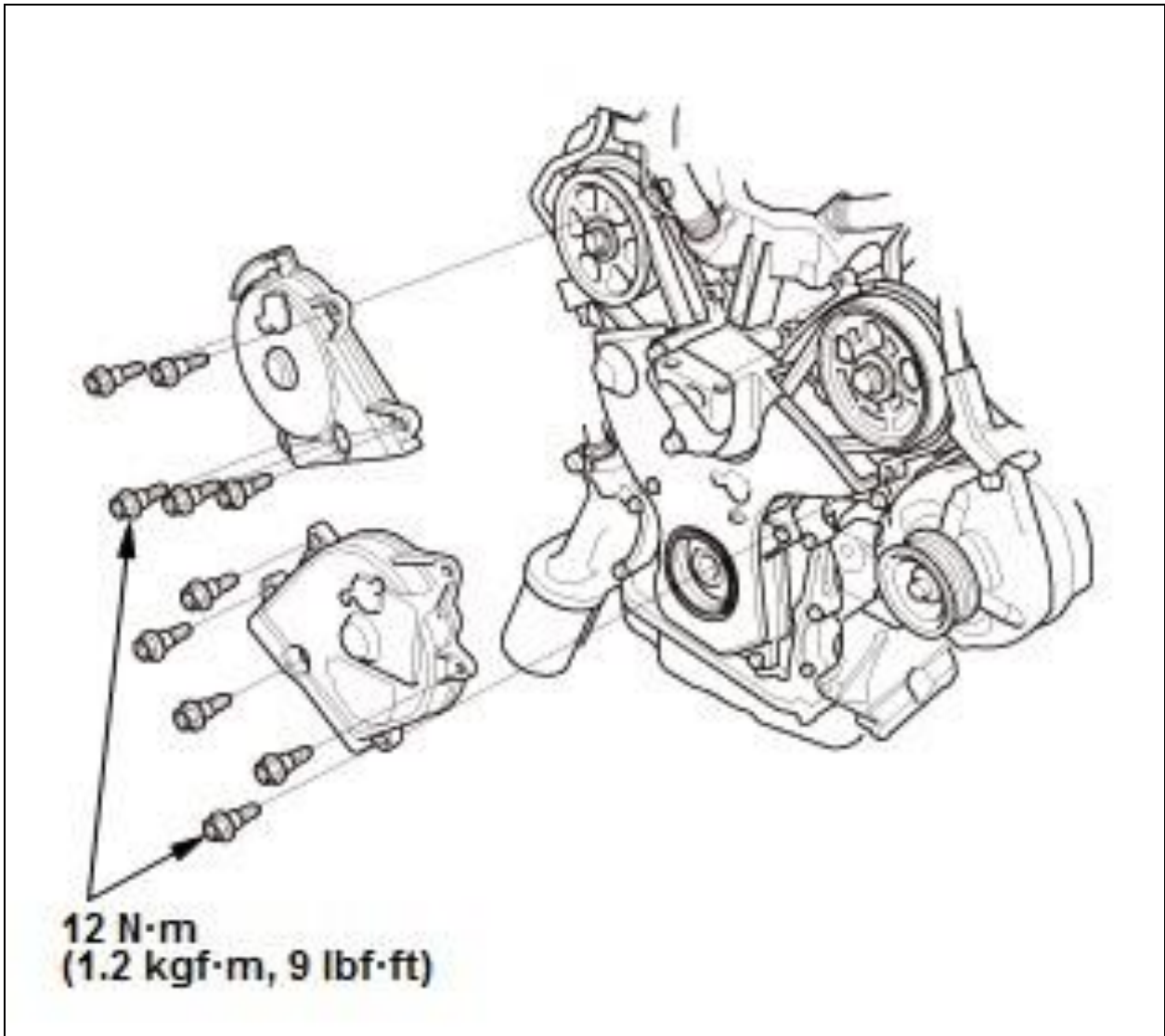

Courtesy of HONDA, U.S.A., INC.

11. Upper Half of Side Engine Mount Bracket - Install
12. Crankshaft Pulley - Install
13. Camshaft Timing - Check

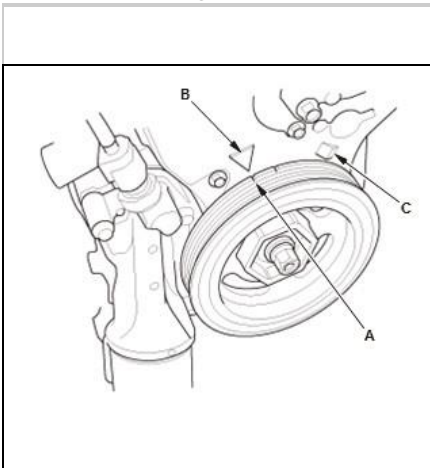

1. Rotate the crankshaft pulley about six turns clockwise so the timing belt positions itself on the pulleys
2. Turn the crankshaft pulley so its white mark (A) lines up with the pointer (B).

NOTE: The other pointer (C) is not used.

FRONT

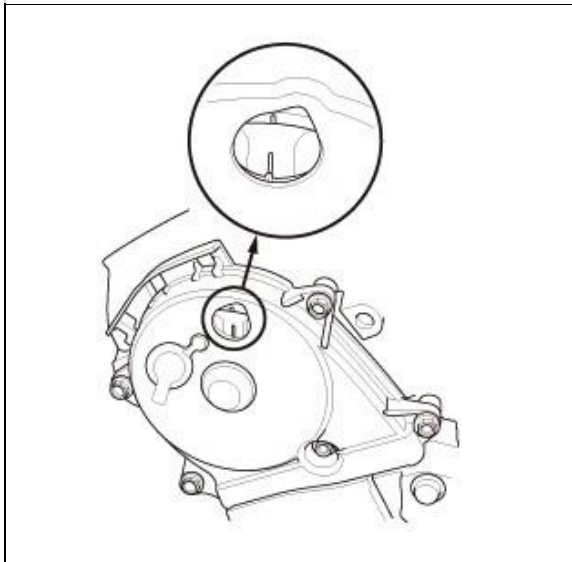
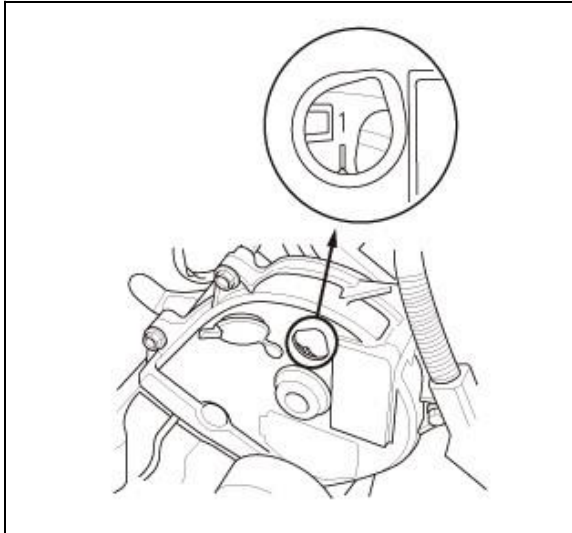

3. Check the camshaft pulley marks.

NOTE: If the marks are not aligned, rotate the crankshaft 360 degrees, and recheck the camshaft pulley mark:

1. If the camshaft pulley marks are at T drive belt auto-tensioner install.
2. If the camshaft pulley marks are not aligned, remove the timing belt and reinstall belt.

Courtesy of HONDA, U.S.A., INC. HONDA, U.S.A., INC.

REAR

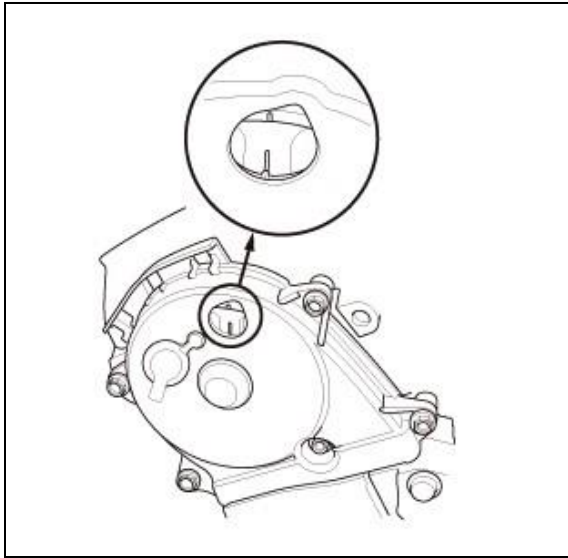
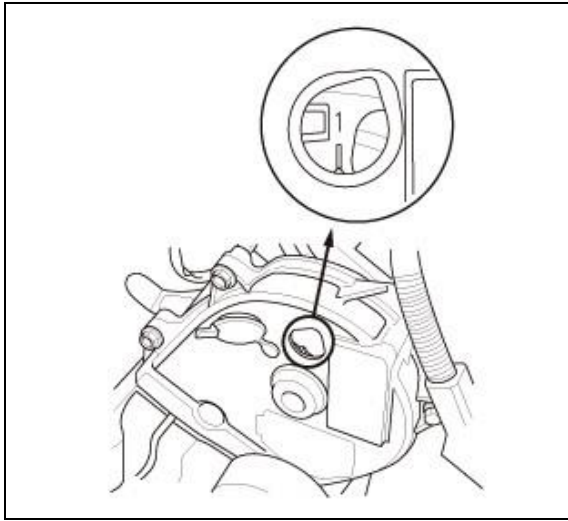

Courtesy of HONDA, U.S.A., INC. HONDA, U.S.A., INC.

- 14. Drive Belt Auto-Tensioner - Install
- 15. Engine Undercover - Install
- 16. Right Front Wheel - Install
- 17. CKP Pattern - Clear/Learn