

Timing Belt Removal And Installation (2013-15)

Removal

1. Vehicle - Lift

1. Raise and support the vehicle .

2. Right Front Wheel - Remove

1. Remove the right front wheel .

3. Engine Undercover - Remove

1. Remove the engine undercover .

4. No. 1 Piston at Top Dead Center - Set (Crank Side)

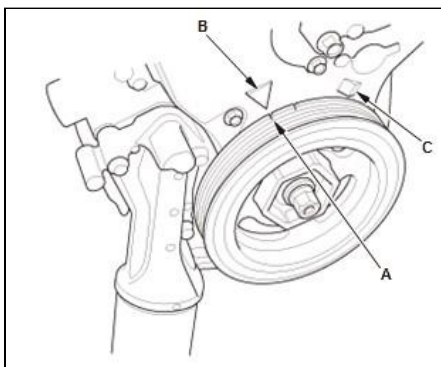

Courtesy of HONDA, U.S.A., INC.

1. Turn the crankshaft so its white mark (A) on the crankshaft pulley lines up with the pointer (B).

NOTE: The other pointer (C) is not used.

5. No. 1 Piston at Top Dead Center - Set (Cam Side)

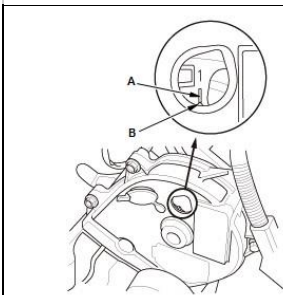

Courtesy of HONDA, U.S.A., INC.

1. Check that the No. 1 piston top dead center (TDC) mark (A) on the front camshaft pulley and the pointer (B) on the front upper cover are aligned.

NOTE: If the marks are not aligned, rotate the crankshaft 360 degrees, and recheck the camshaft pulley mark.

6. Drive Belt Auto-Tensioner - Remove

1. Remove the drive belt auto-tensioner .

7. Crankshaft Pulley - Remove

1. Remove the crankshaft pulley .

8. Engine Jack - Support

1. Lift and support the engine with a jack and a wood block under the oil pan.

9. Side Engine Mount Bracket - Remove

1. Remove the upper half of the side engine mount bracket.

10. Upper Cover - Remove

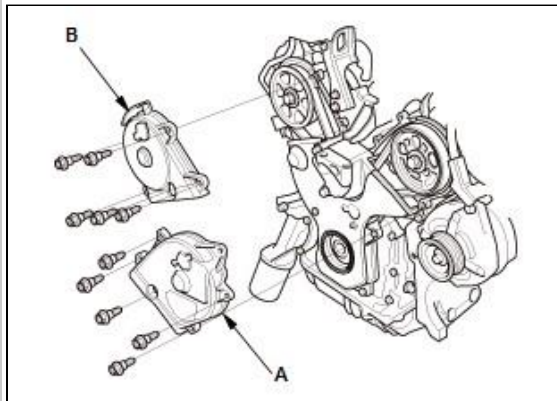

1. Remove the front upper cover (A) and the rear upper cover (B).

Courtesy of HONDA, U.S.A., INC.

11. Lower Cover - Remove

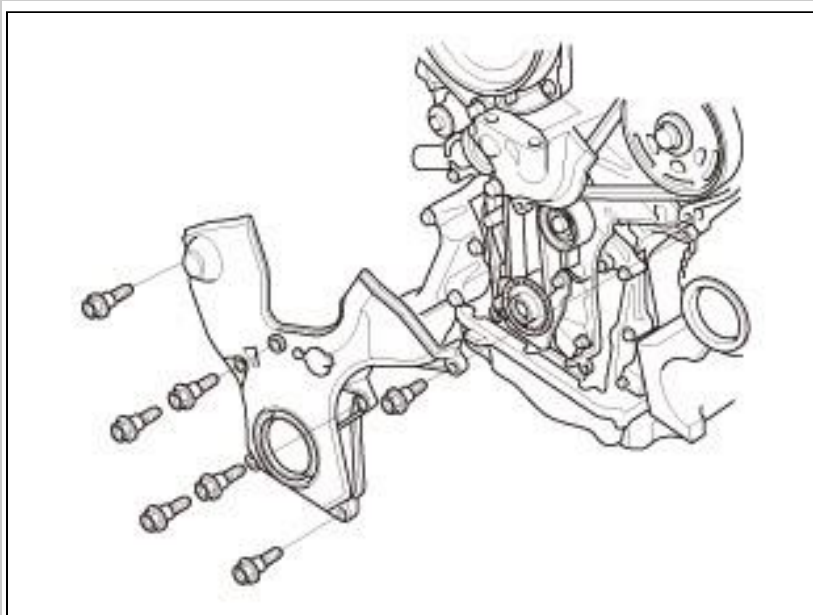

1. Remove the lower cover.

Courtesy of HONDA, U.S.A., INC.

12. Timing Belt Adjuster - Hold

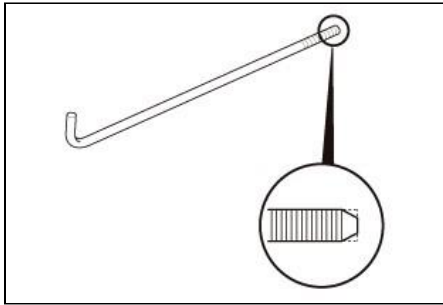

Courtesy of HONDA, U.S.A., INC.

1. Remove one of the battery clamp bolts from the battery tray, and grind the end of it as shown.

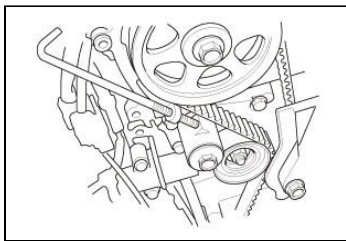

Courtesy of HONDA, U.S.A., INC.

2. Thread the battery clamp bolt in as shown to hold the timing belt adjuster in its current position. Tighten it by hand, do not use a wrench.

13. Timing Belt Guide Plate - Remove

1. Remove the lower half of the side engine mount

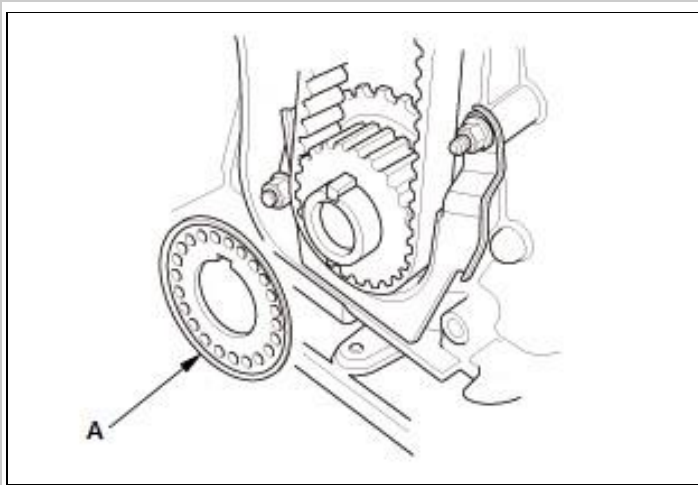

Courtesy of HONDA, U.S.A., INC.

1. Remove the timing belt guide plate (A).

14. Side Engine Mount Bracket - Remove

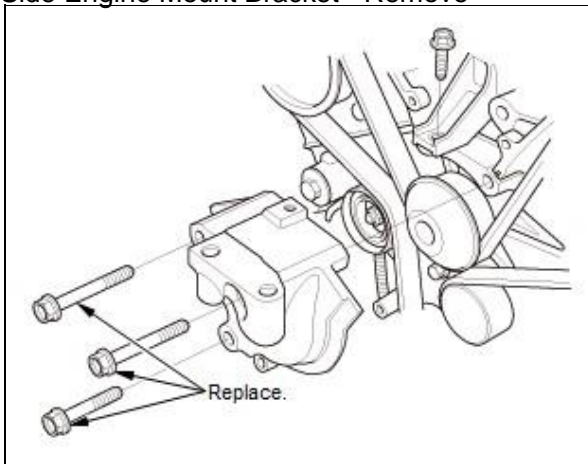

Courtesy of HONDA, U.S.A., INC.

bracket.

15. Timing Belt - Remove

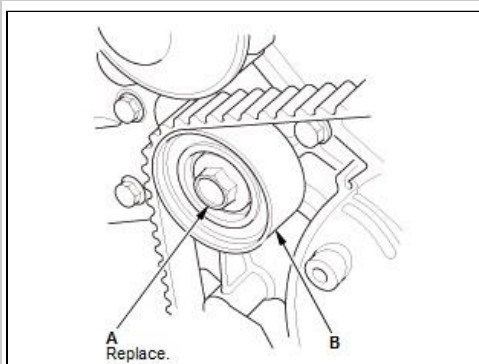

Courtesy of HONDA, U.S.A., INC.

1. Remove the idler pulley bolt (A) and the idler pulley (B).
Discard the idler pulley bolt
2. Remove the timing belt.

Installation

NOTE:

- The following procedure is for installation of a used timing belt. If you are installing a new timing belt, refer to the timing belt auto-tensioner installation procedure.
- Clean the timing belt pulleys, the timing belt guide plate, and the upper and lower covers.

1. No. 1 Piston at Top Dead Center - Set (Crank Side)

1. Set the timing belt drive pulley to top dead center (TDC) by aligning the TDC mark (A) on the tooth of the timing belt drive pulley with the pointer (B) on the oil pump.

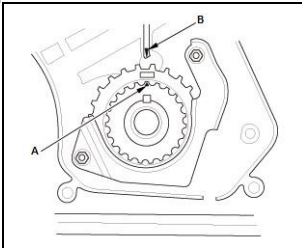

Courtesy of HONDA, U.S.A., INC.

2. No. 1 Piston at Top Dead Center - Set (Cam Side)

FRONT

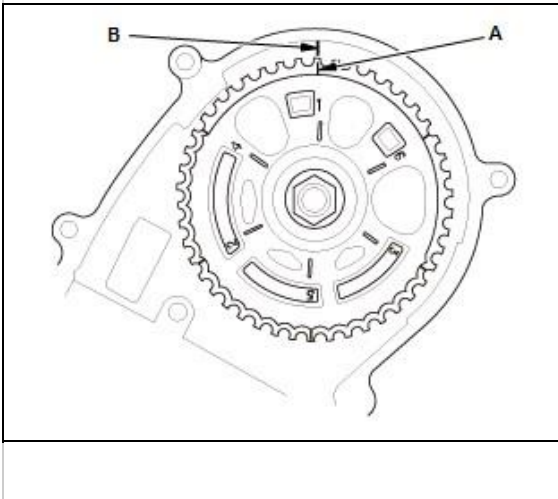

1. Set the camshaft pulleys to TDC by aligning the TDC marks (A) on the camshaft pulleys with the pointers (B) on the back covers.

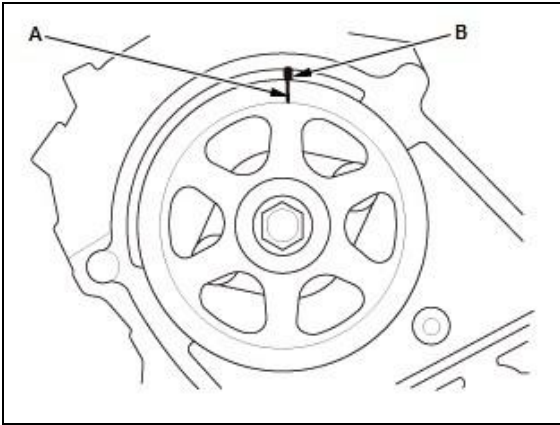

Courtesy of HONDA, U.S.A., INC. HONDA, U.S.A., INC.

REAR

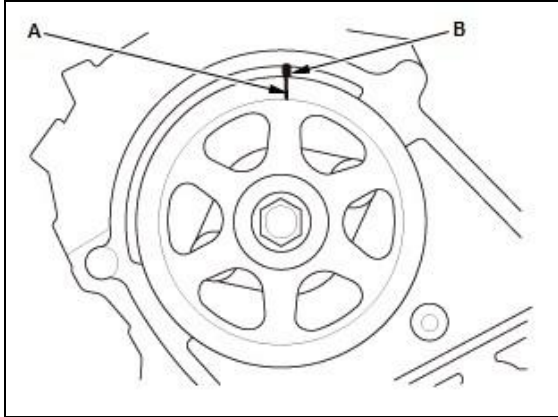
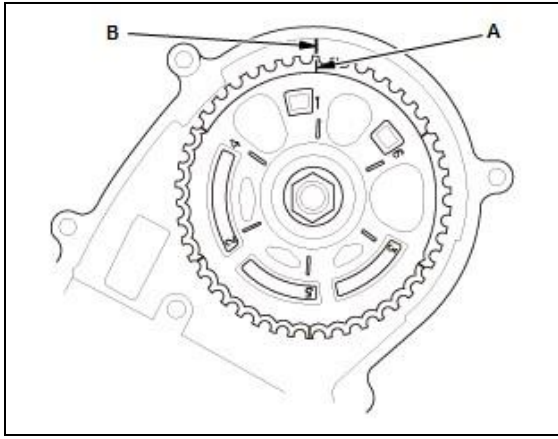

Courtesy of HONDA, U.S.A., INC. HONDA, U.S.A., INC.

3. Idler Pulley - Loosely Install

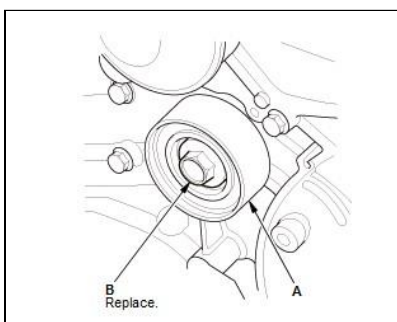

Courtesy of HONDA, U.S.A., INC.

1. Loosely install the idler pulley (A) with a new idler pulley bolt (B) so the pulley can move but does not come off.

4. Timing Belt - Install

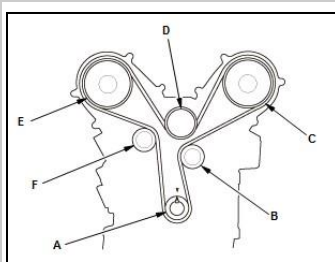

Courtesy of HONDA, U.S.A., INC.

1. If the timing belt auto-tensioner has extended and the timing belt cannot be installed, do the timing belt auto-tensioner installation procedure .
2. Install the timing belt in a counterclockwise sequence starting with the drive pulley. Take care not to damage the timing belt during installation:

1. Drive pulley (A)
2. Idler pulley (B)
3. Front camshaft pulley (C)
4. Water pump pulley (D)
5. Rear camshaft pulley (E)
6. Adjusting pulley (F)

5. Idler Pulley Bolt - Tighten

Fig 1: Idler Pulley Bolt With Torque Specifications

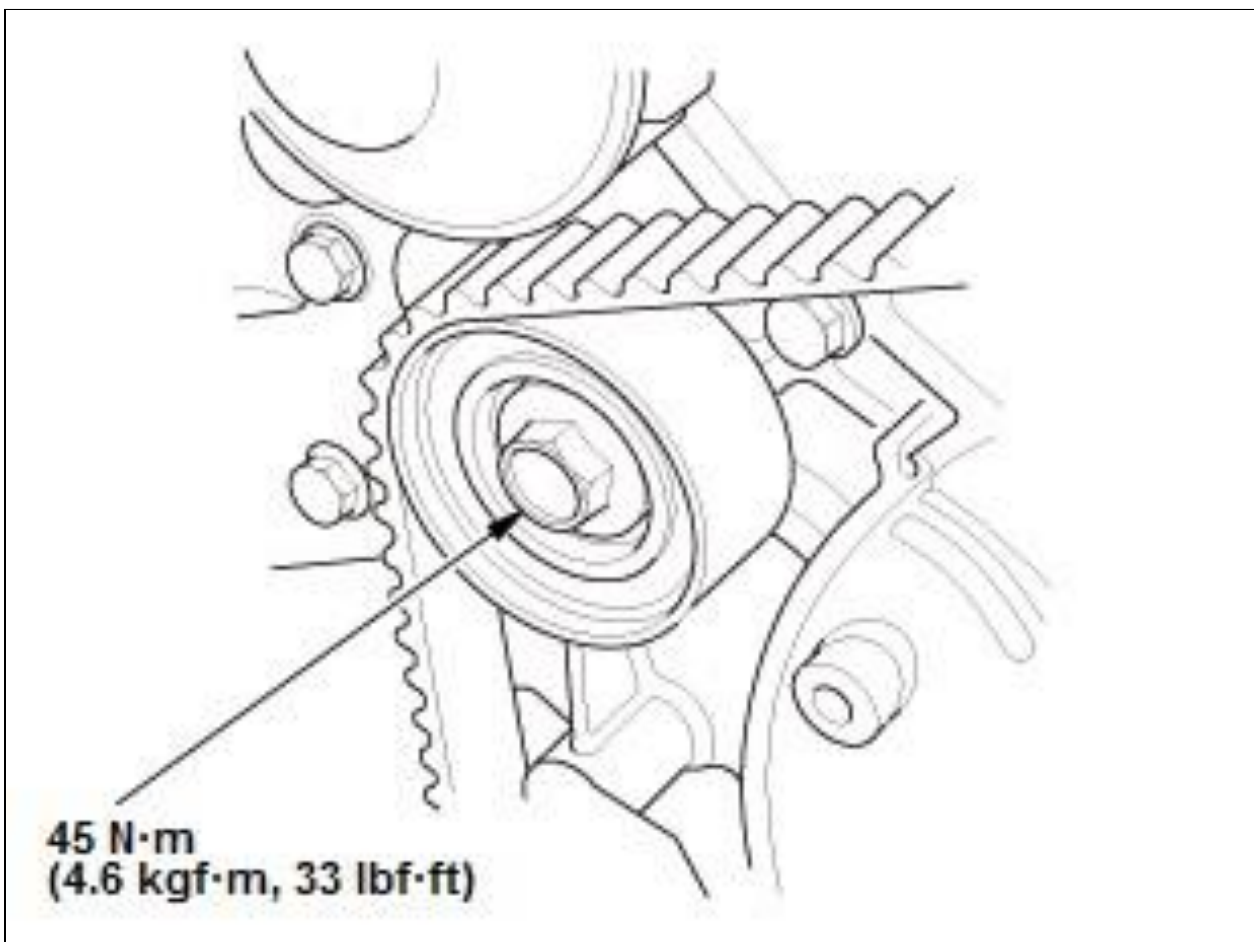

Courtesy of HONDA, U.S.A., INC.

1. Tighten the idler pulley bolt.

6. Battery Clamp Bolt - Remove

1. Remove the battery clamp bolt from the back cover.

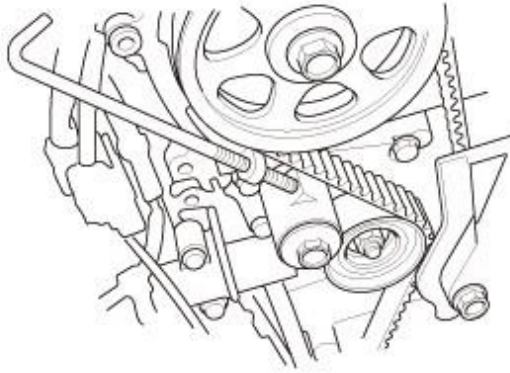

Courtesy of HONDA, U.S.A., INC.

7. Side Engine Mount Bracket - Install

Fig 2: Side Engine Mount Bracket With Torque Specifications

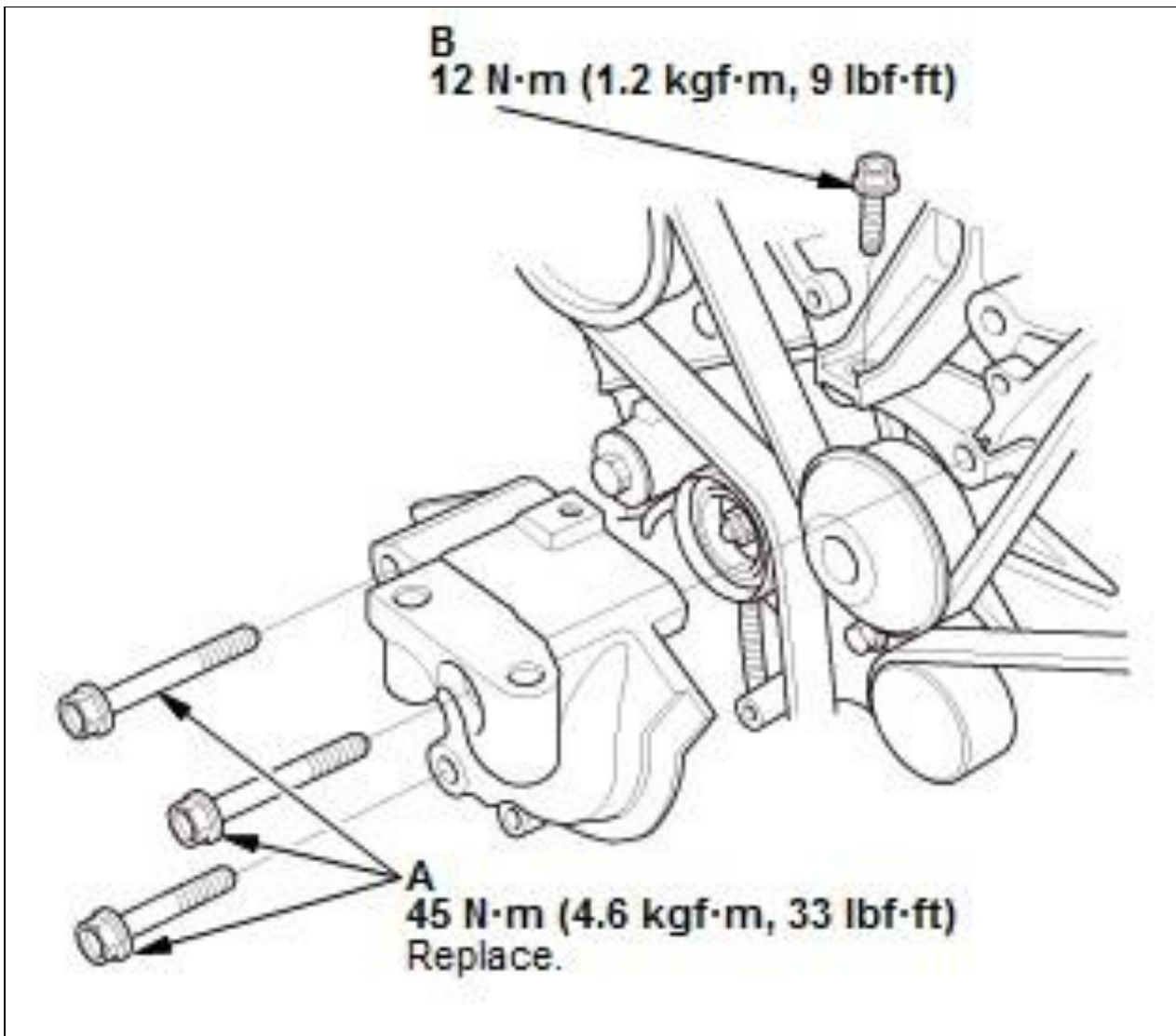

Courtesy of HONDA, U.S.A., INC.

1. Install the lower half of the side engine mount bracket using new bolts (A) and bolt (B).

8. Timing Belt Guide Plate - Install

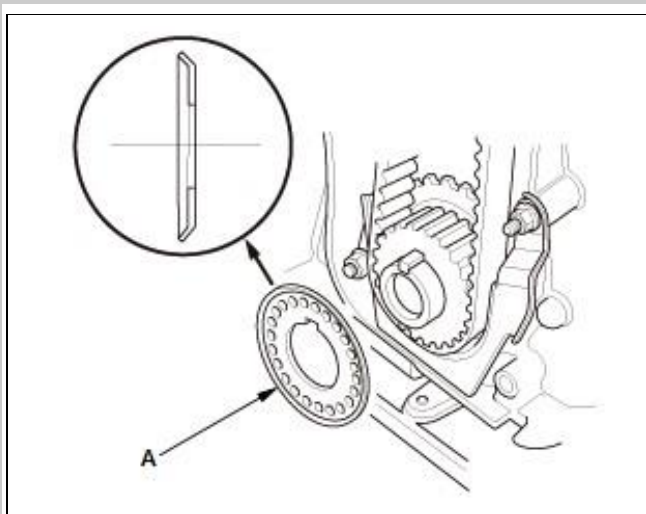

1. Install the timing belt guide plate (A) as shown.

Courtesy of HONDA, U.S.A., INC.

9. Lower Cover - Install

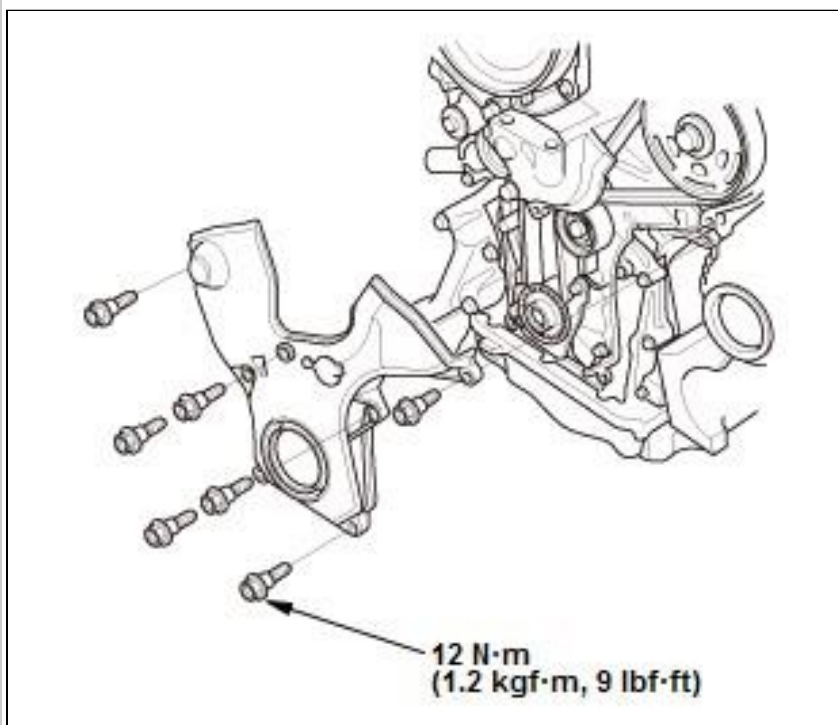

1. Install the lower cover.

Courtesy of HONDA, U.S.A., INC.

10. Upper Cover - Install

1. Install the front upper cover (A) and the rear upper cover (B).

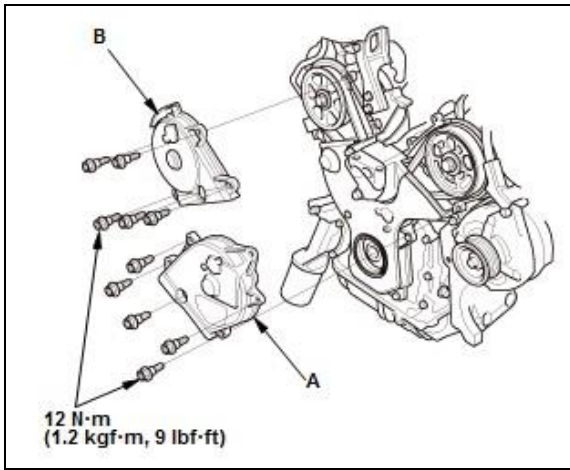

Courtesy of HONDA, U.S.A., INC.

11. Side Engine Mount Bracket - Install

1. Install the upper half of the side engine mount bracket.

12. Crankshaft Pulley - Install

1. Install the crankshaft pulley .

13. Camshaft Timing - Check

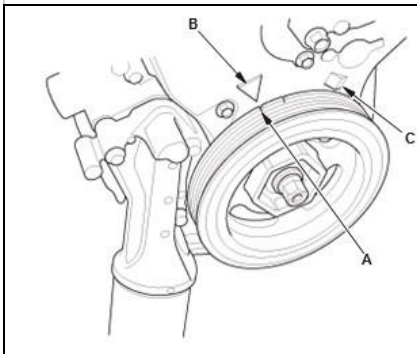

Courtesy of HONDA, U.S.A., INC.

1. Rotate the crankshaft pulley about six turns clockwise so the timing belt positions itself on the pulleys
2. Turn the crankshaft pulley so its white mark (A) lines up with the pointer (B).

NOTE: The other pointer (C) is not used.

FRONT

3. Check the camshaft pulley marks.

NOTE: If the marks are not aligned, rotate the crankshaft 360 degrees, and recheck the camshaft pulley mark:

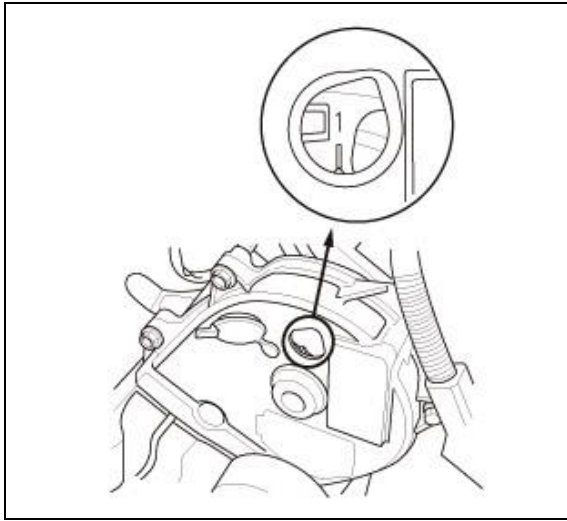

1. If the camshaft pulley marks are at TDC, go to drive belt auto-tensioner install.
2. If the camshaft pulley marks are not at TDC, remove the timing belt and reinstall the timing belt.

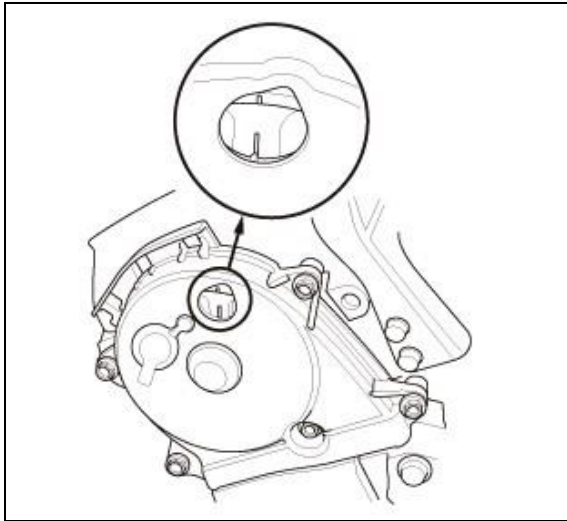

Courtesy of HONDA, U.S.A., INC. HONDA, U.S.A., INC.

REAR

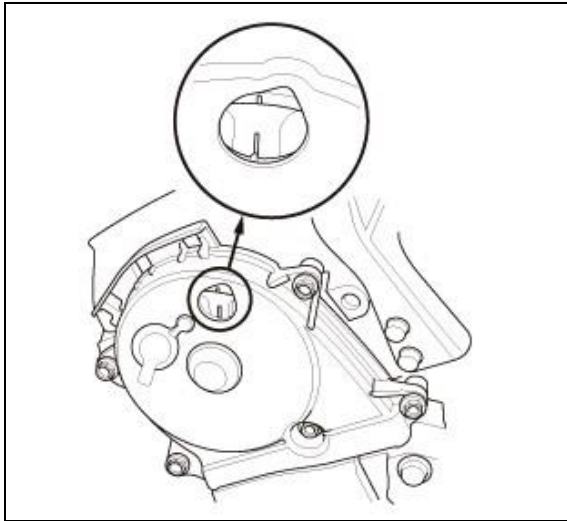
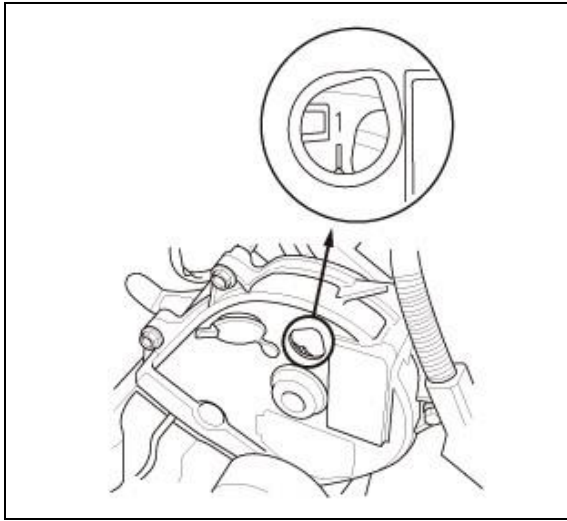

Courtesy of HONDA, U.S.A., INC. HONDA, U.S.A., INC.

14. Drive Belt Auto-Tensioner - Install

1. Install the drive belt auto-tensioner .

15. Engine Undercover - Install

1. Install the engine undercover .

16. Right Front Wheel - Install

1. Install the right front wheel .

17. CKP Pattern - Clear/Learn

1. Do the CKP pattern clear/CKP pattern learn procedure .