

RDX ANTI-THEFT 2013-2018

Fig 1: Anti-theft Circuit (1 of 6)

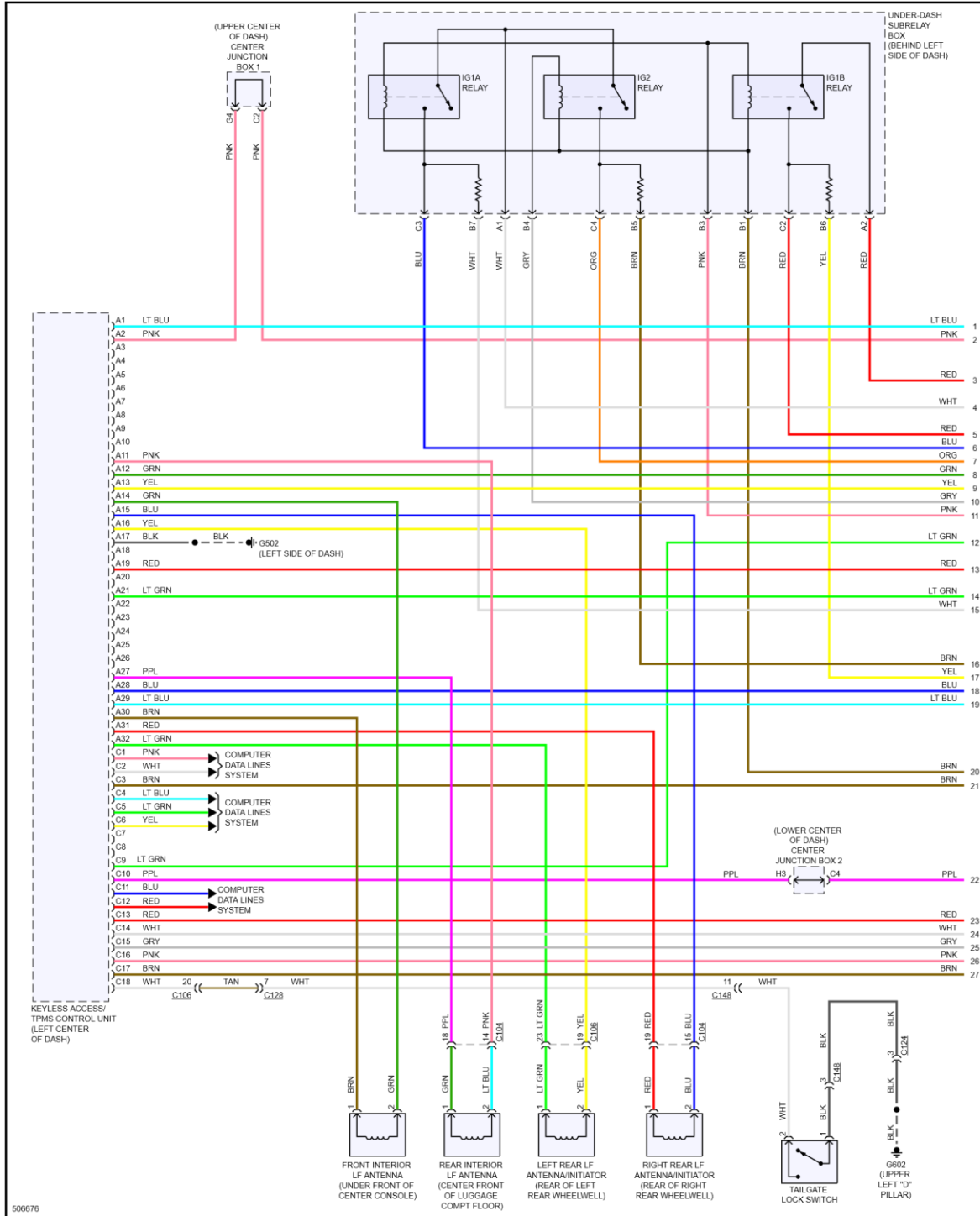

Fig 2: Anti-theft Circuit (2 of 6)

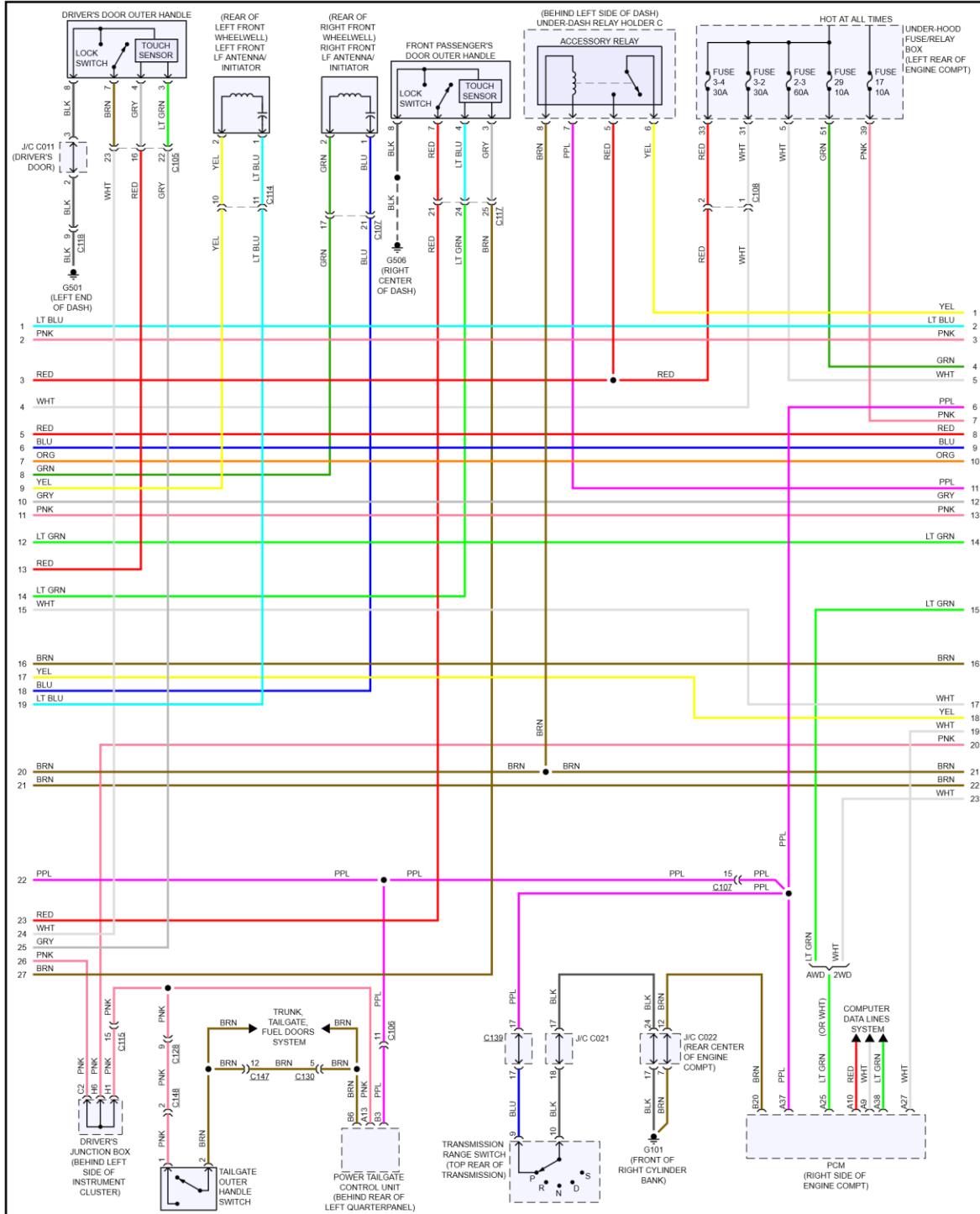

Fig 3: Anti-theft Circuit (3 of 6)

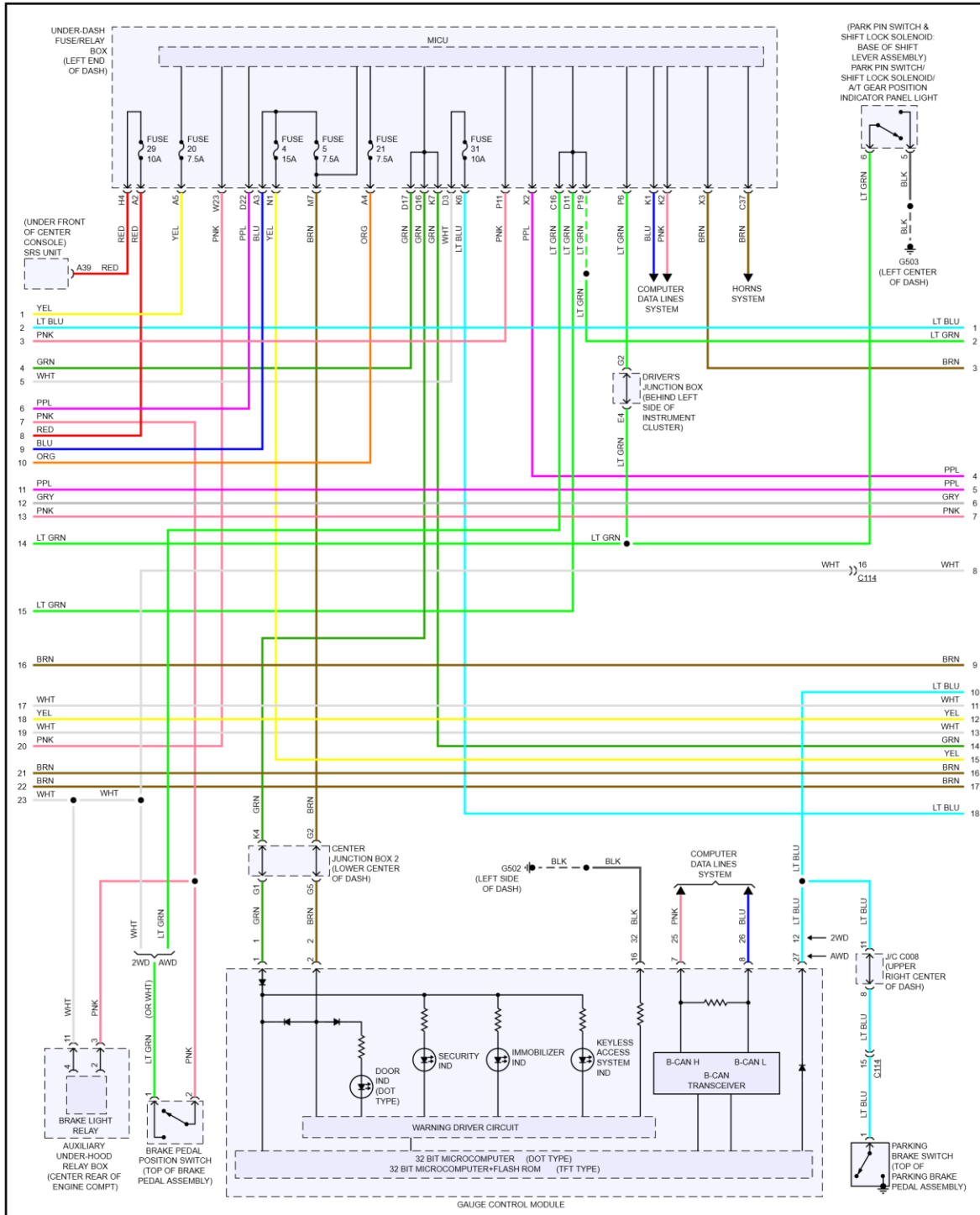

Fig 4: Anti-theft Circuit (4 of 6)

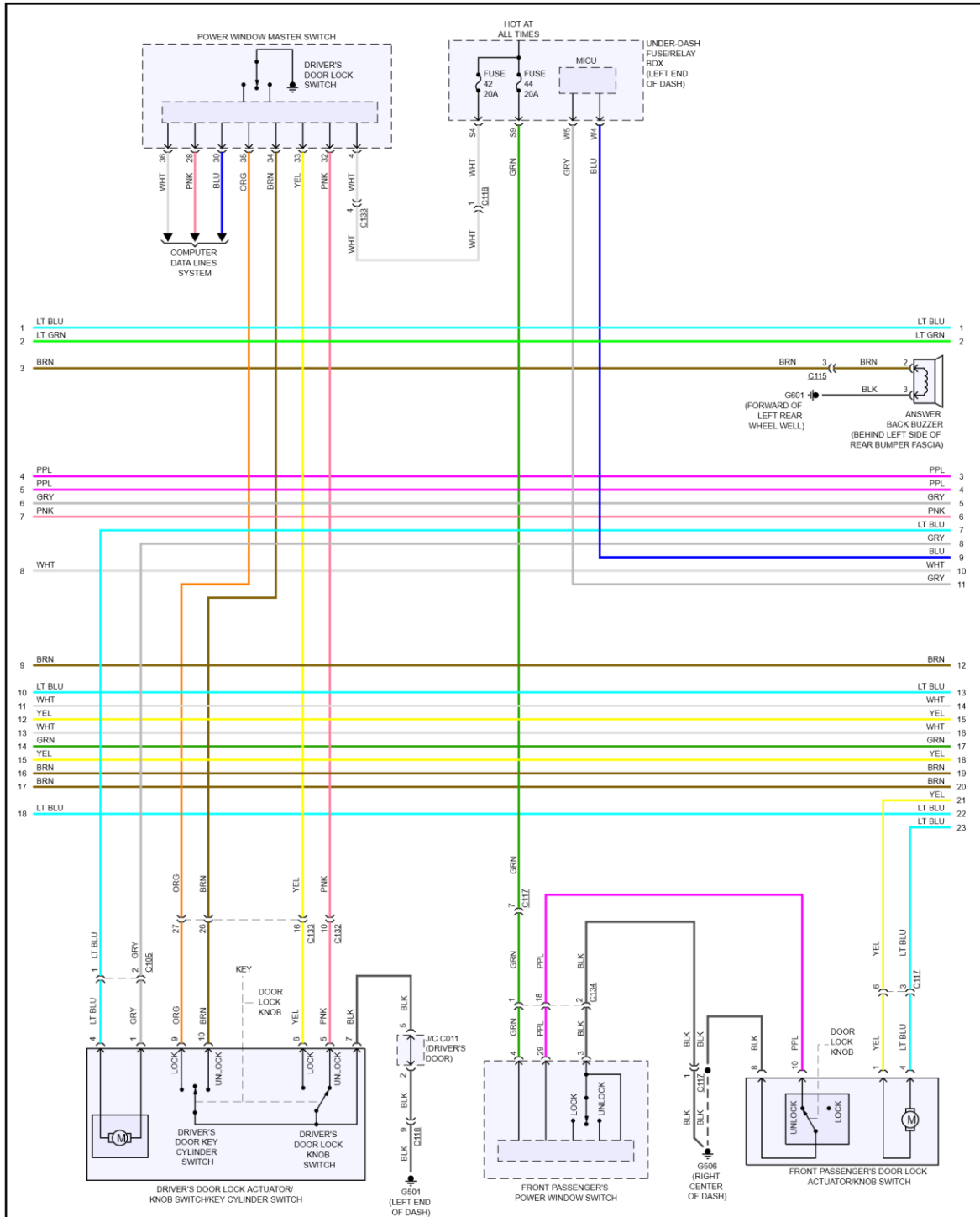

Fig 5: Anti-theft Circuit (5 of 6)

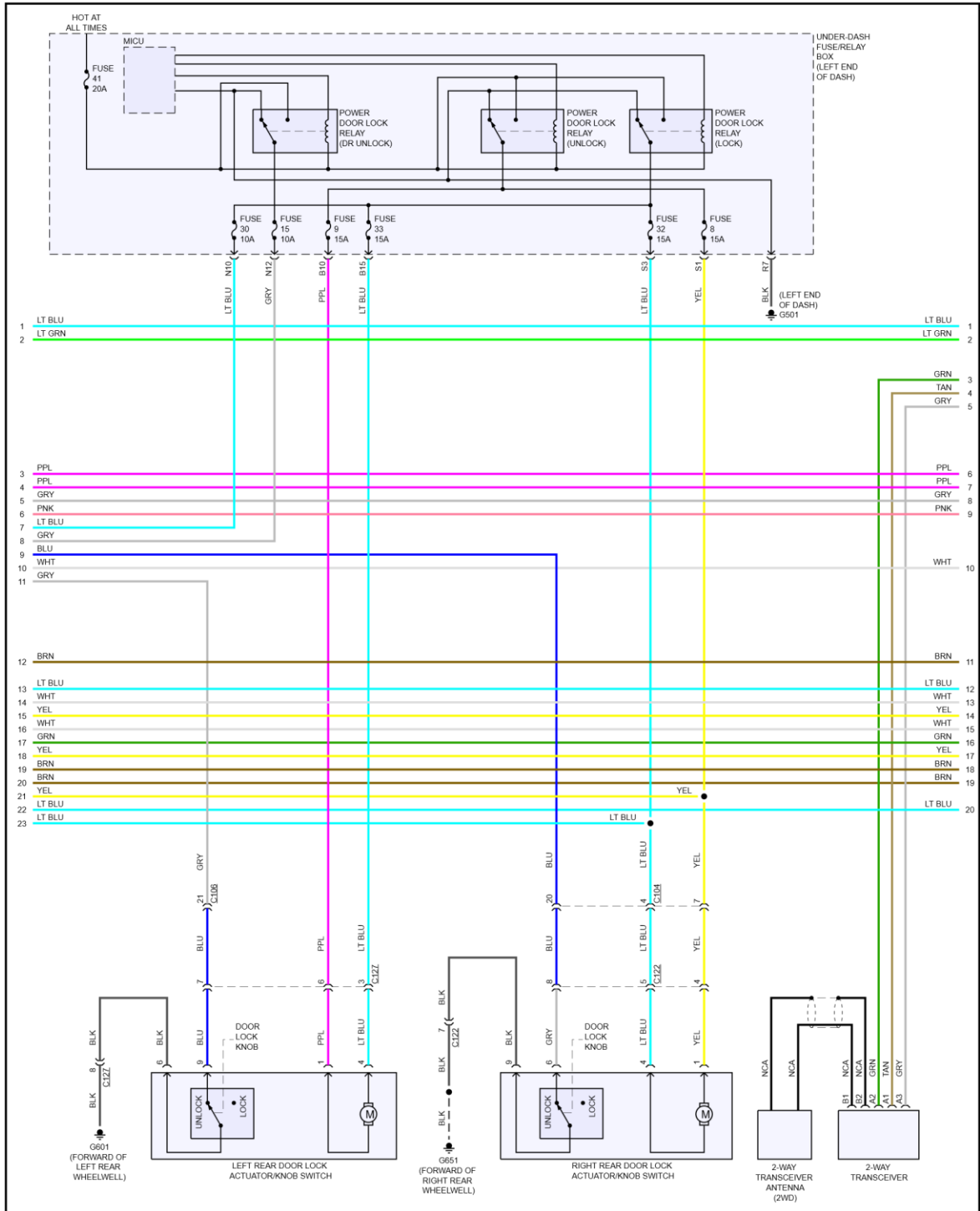

Fig 6: Anti-theft Circuit (6 of 6)

