

YMMS: 2018 Acura RDX Base
Engine: 3.5L Eng
VIN:

Oct 17, 2019
License:
Odometer:

REMOVAL & INSTALLATION > TIMING BELT AUTO-TENSIONER REMOVAL AND INSTALLATION (2016-18) > REMOVAL

1. Timing Belt - Remove
2. Battery Clamp Bolt - Remove

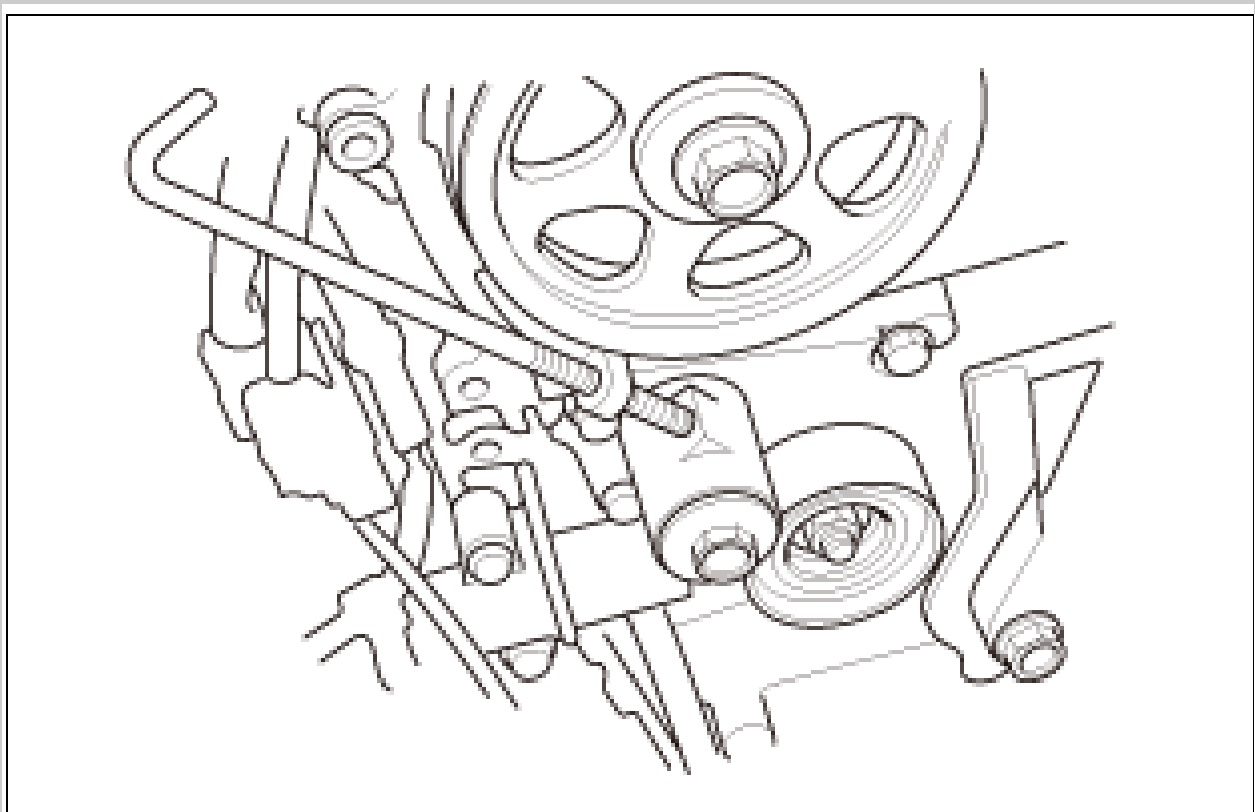

Courtesy of HONDA, U.S.A., INC.

3. Timing Belt Auto-Tensioner - Remove

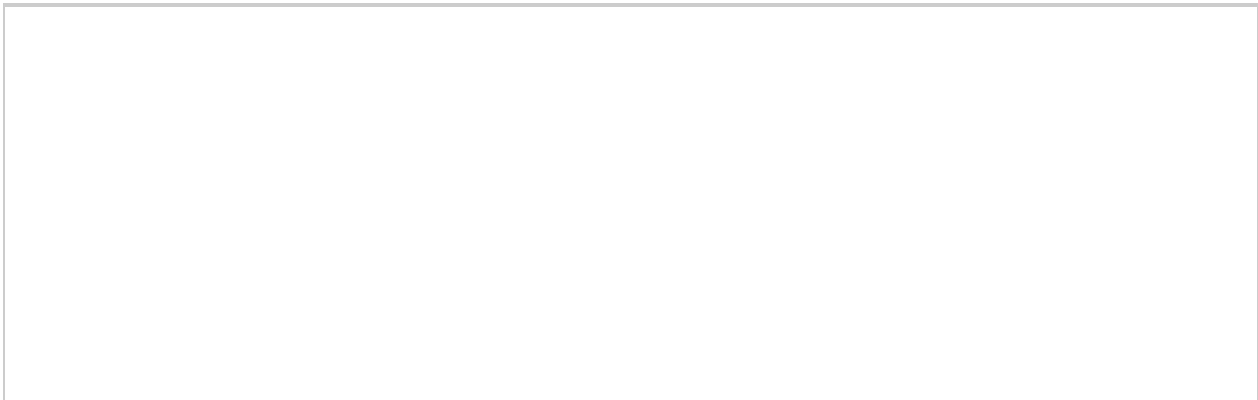

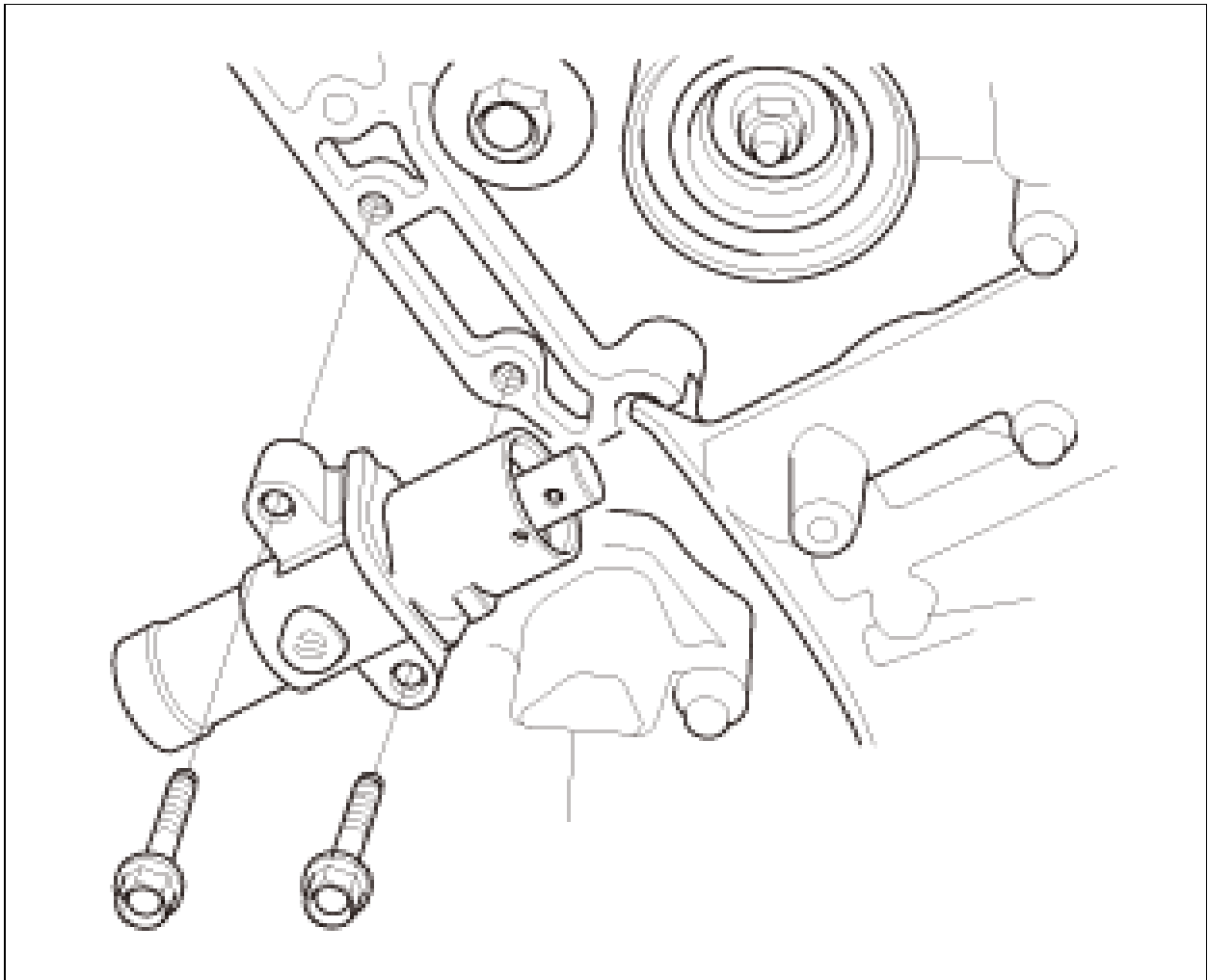

Courtesy of HONDA, U.S.A., INC.

REMOVAL & INSTALLATION > TIMING BELT AUTO-TENSIONER REMOVAL AND INSTALLATION (2016-18) > INSTALLATION

NOTE: Clean the timing belt pulleys, the timing belt guide plate, and the upper and lower covers.

1. Timing Belt Auto-Tensioner - Install

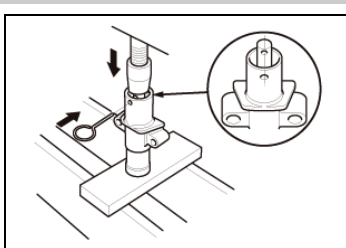

1. Align the holes on the rod and the housing of the timing belt auto-tensioner
2. Use a hydraulic press to slowly compress the timing belt auto-tensioner. Insert a 2.0 mm (5/64 in) pin through the housing and the rod.

Courtesy of HONDA, U.S.A., INC.

NOTE: The compression pressure should not exceed 9,800 N (999.3 kgf, 2,203.1 lbf).

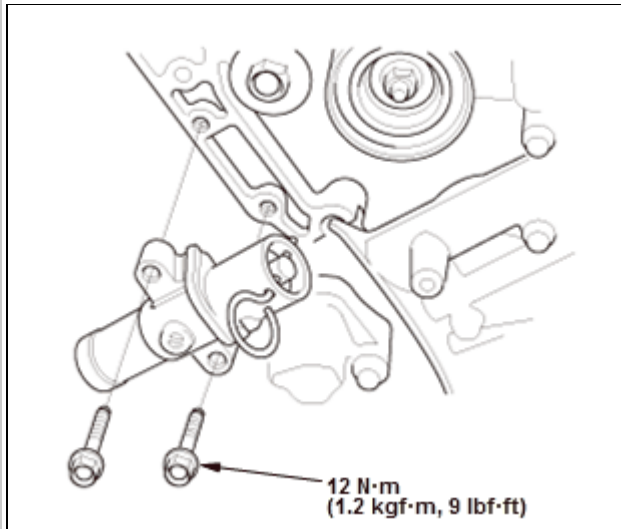

Courtesy of HONDA, U.S.A., INC.

3. Install the timing belt auto-tensioner.

NOTE: Make sure the pin stays in place.

2. Timing Belt Adjuster - Hold

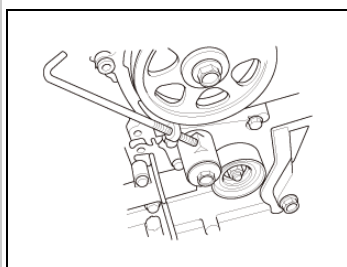

Courtesy of HONDA, U.S.A., INC.

1. Thread the battery clamp bolt in as shown to hold the timing belt adjuster in its current position. Tighten it by hand, do not use a wrench.

3. No. 1 Piston at Top Dead Center - Set (Crank Side)

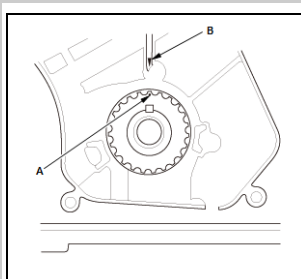

Courtesy of HONDA, U.S.A., INC.

1. Set the timing belt drive pulley to top dead center (TDC) by aligning the TDC mark (A) on the tooth of the timing belt drive pulley with the pointer (B) on the oil pump.

4. No. 1 Piston at Top Dead Center - Set (Cam Side)

FRONT

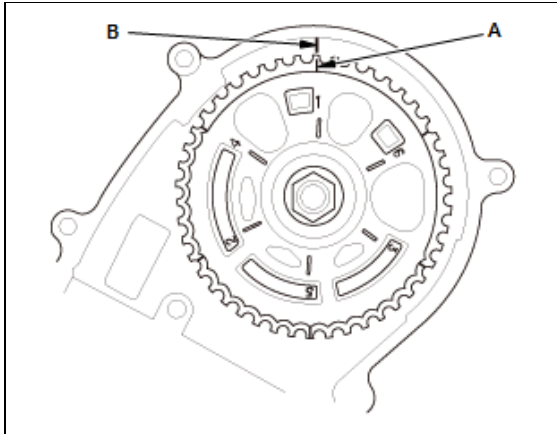

1. Set the camshaft pulleys to TDC by aligning the TDC marks (A) on the camshaft pulleys with the pointers (B) on the back covers.

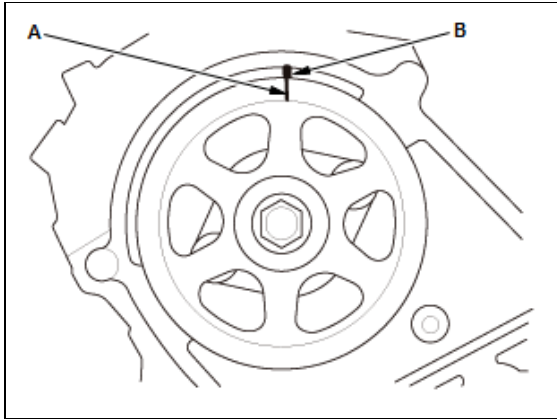

Courtesy of HONDA, U.S.A., INC.HONDA, U.S.A., INC.

REAR

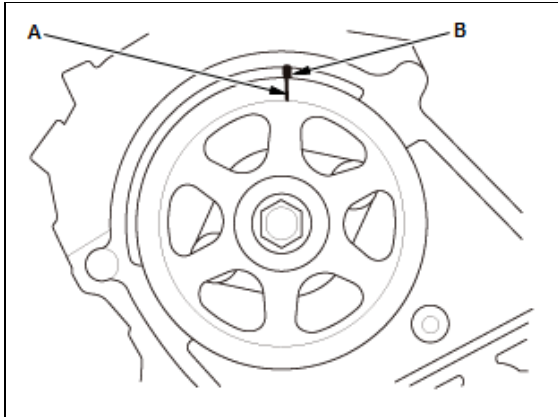
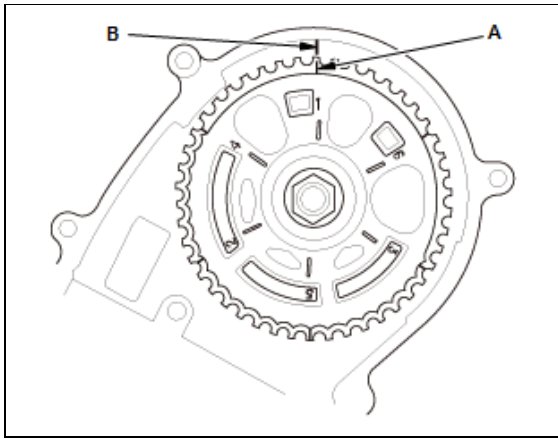

Courtesy of HONDA, U.S.A., INC. HONDA, U.S.A., INC.

5. Idler Pulley - Loosely Install

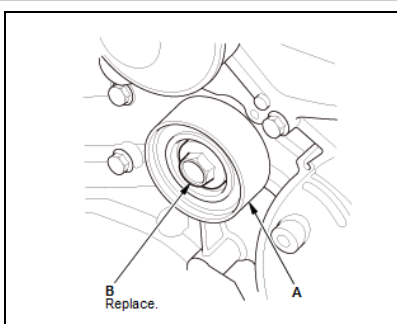

Courtesy of HONDA, U.S.A., INC.

1. Loosely install the idler pulley (A) with a new idler pulley bolt (B) so the pulley can move but does not come off.

6. Timing Belt - Install

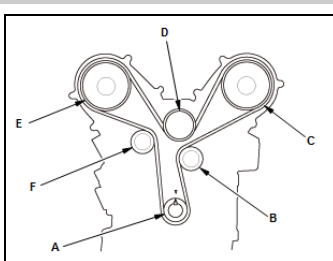

1. Install the timing belt in a counterclockwise sequence starting with the drive pulley. Take care not to damage the timing belt during installation:

1. Drive pulley (A)
2. Idler pulley (B)
3. Front camshaft pulley (C)

Courtesy of HONDA, U.S.A., INC.

- 4. Water pump pulley (D)
- 5. Rear camshaft pulley (E)
- 6. Adjusting pulley (F)

7. Idler Pulley Bolt - Tighten

Fig 1: Idler Pulley Bolt With Torque Specifications

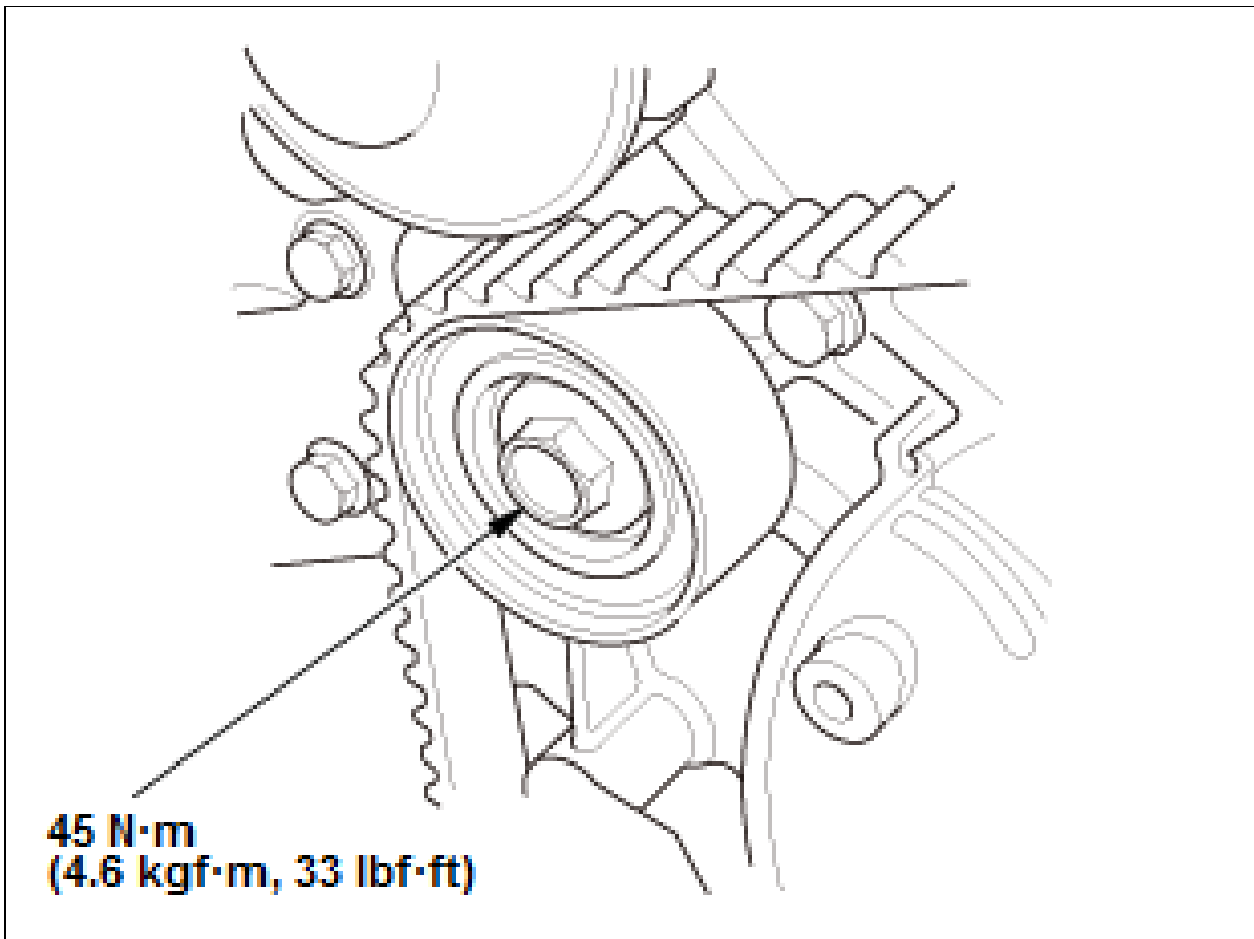

Courtesy of HONDA, U.S.A., INC.

8. Pin - Remove

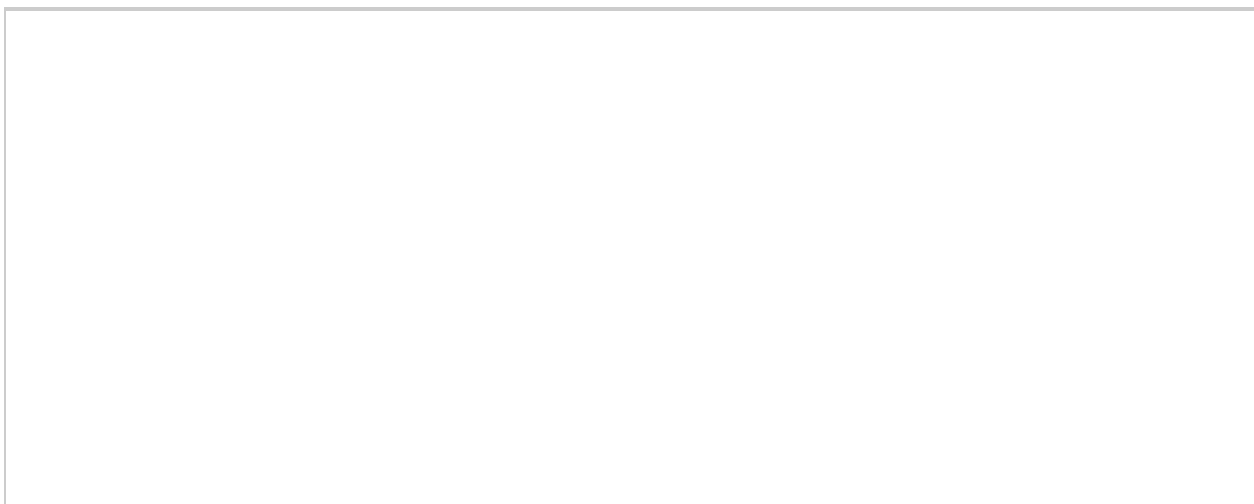

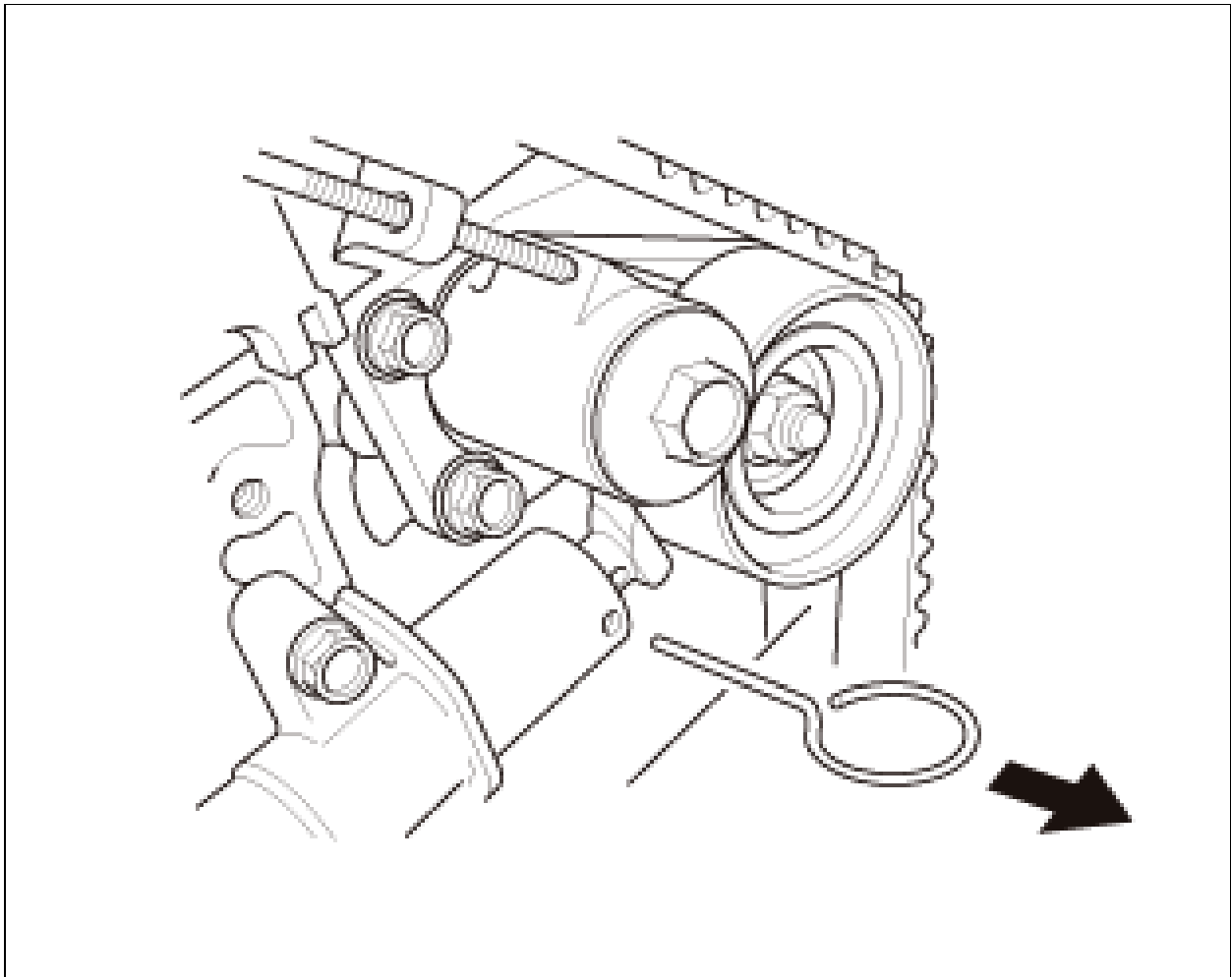

Courtesy of HONDA, U.S.A., INC.

9. Battery Clamp Bolt - Remove

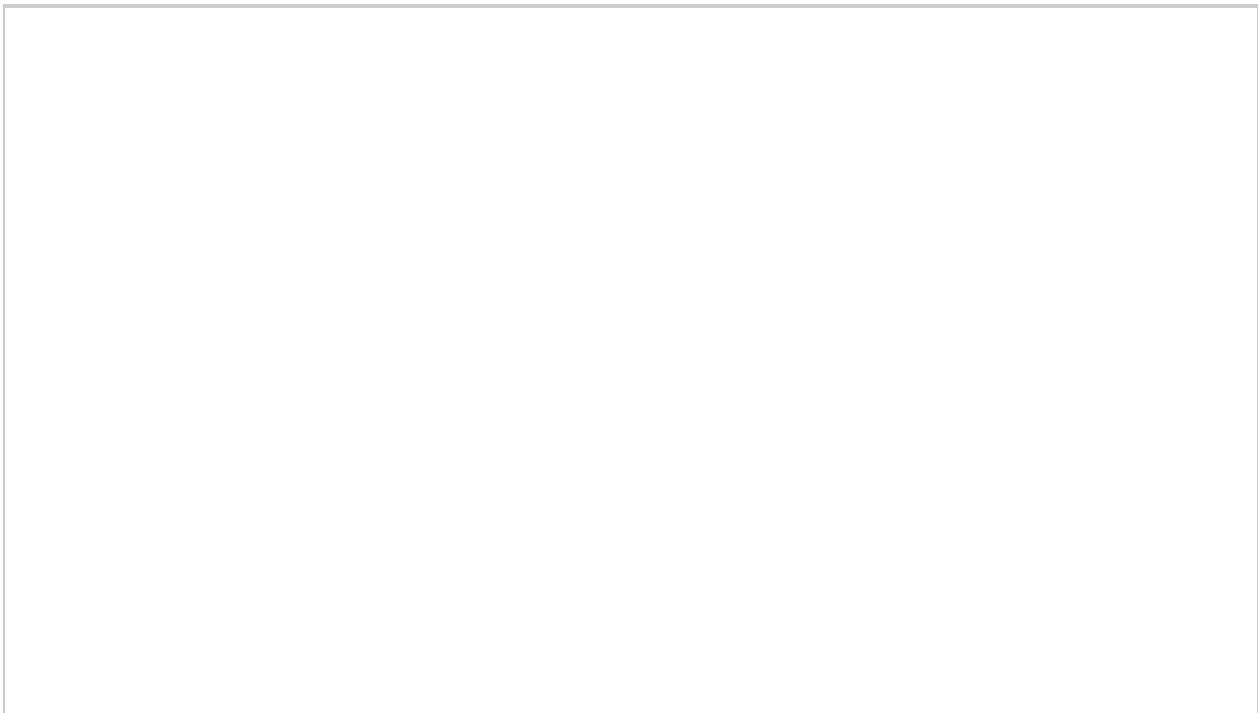

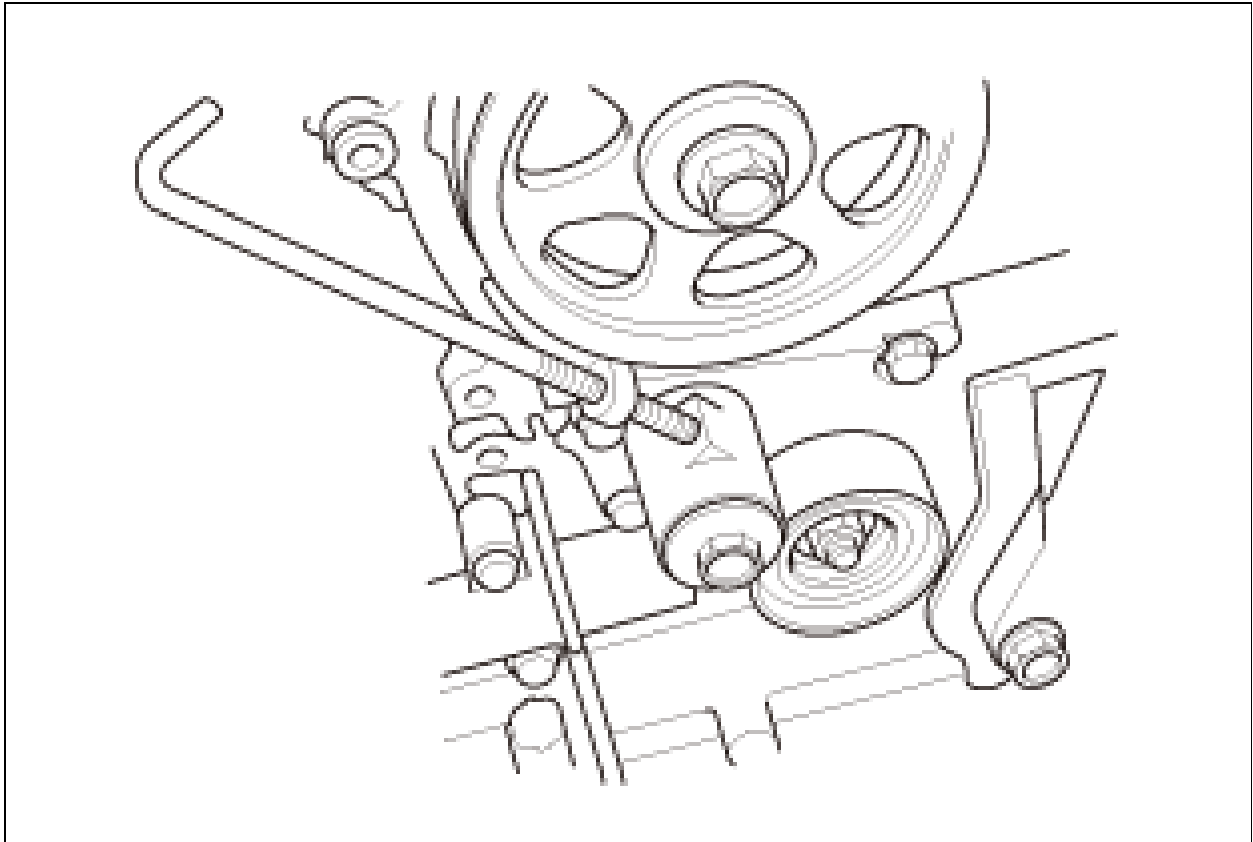

Courtesy of HONDA, U.S.A., INC.

10. Lower Half of Side Engine Mount Bracket - Install

Fig 2: Lower Half of Side Engine Mount Bracket With Torque Specifications

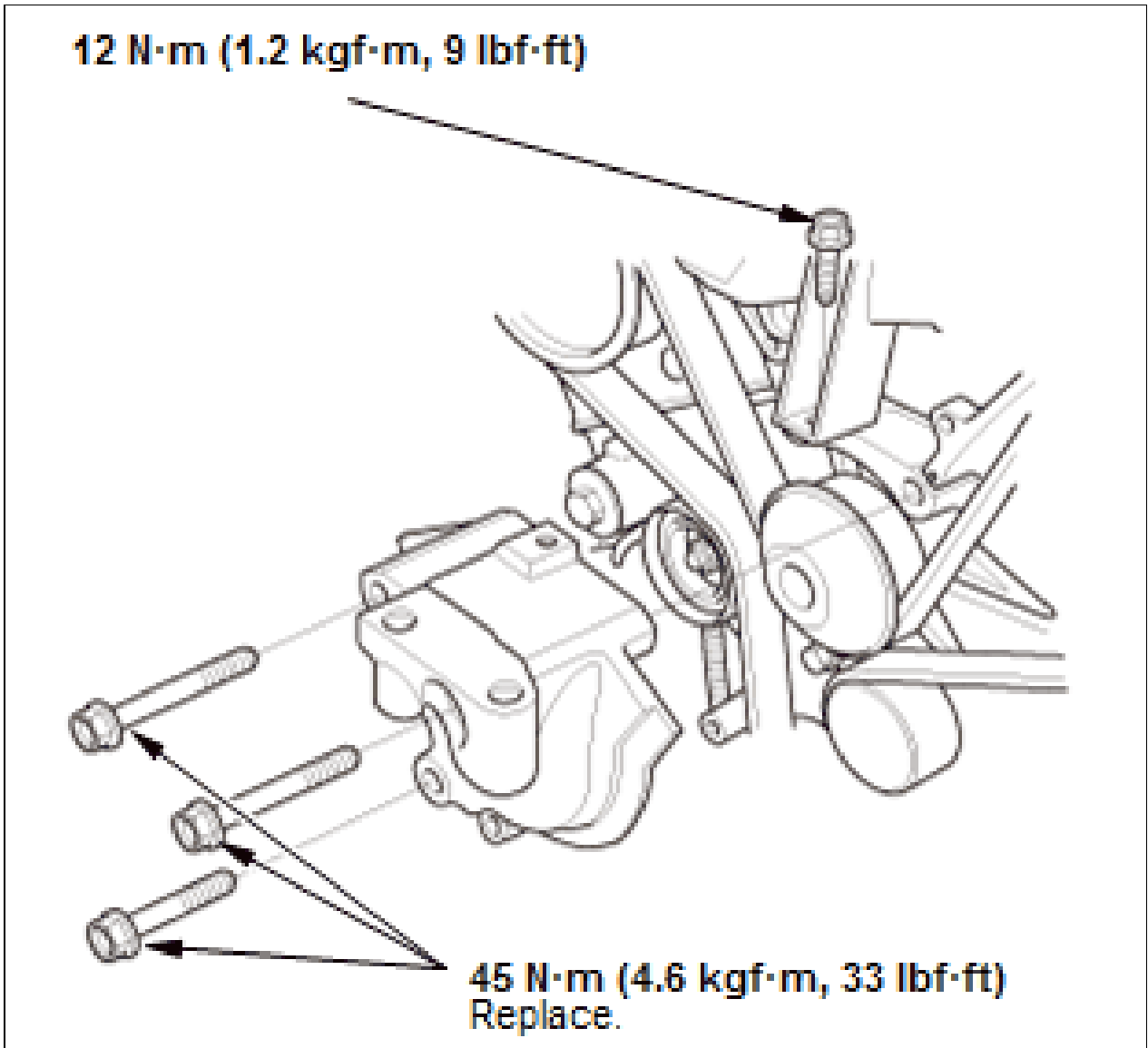

Courtesy of HONDA, U.S.A., INC.

11. Timing Belt Guide Plate - Install

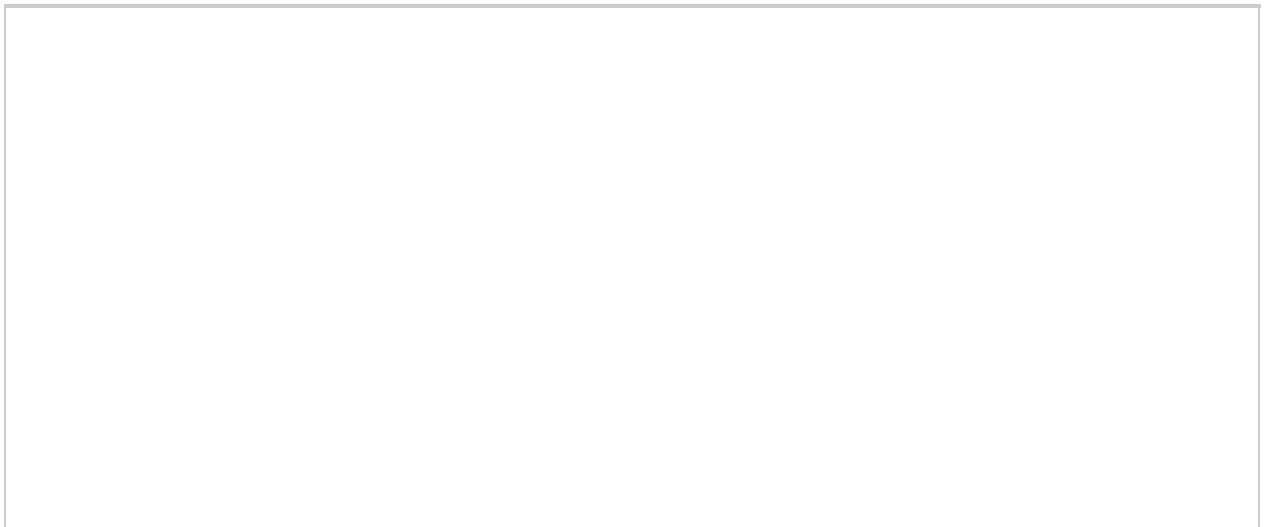

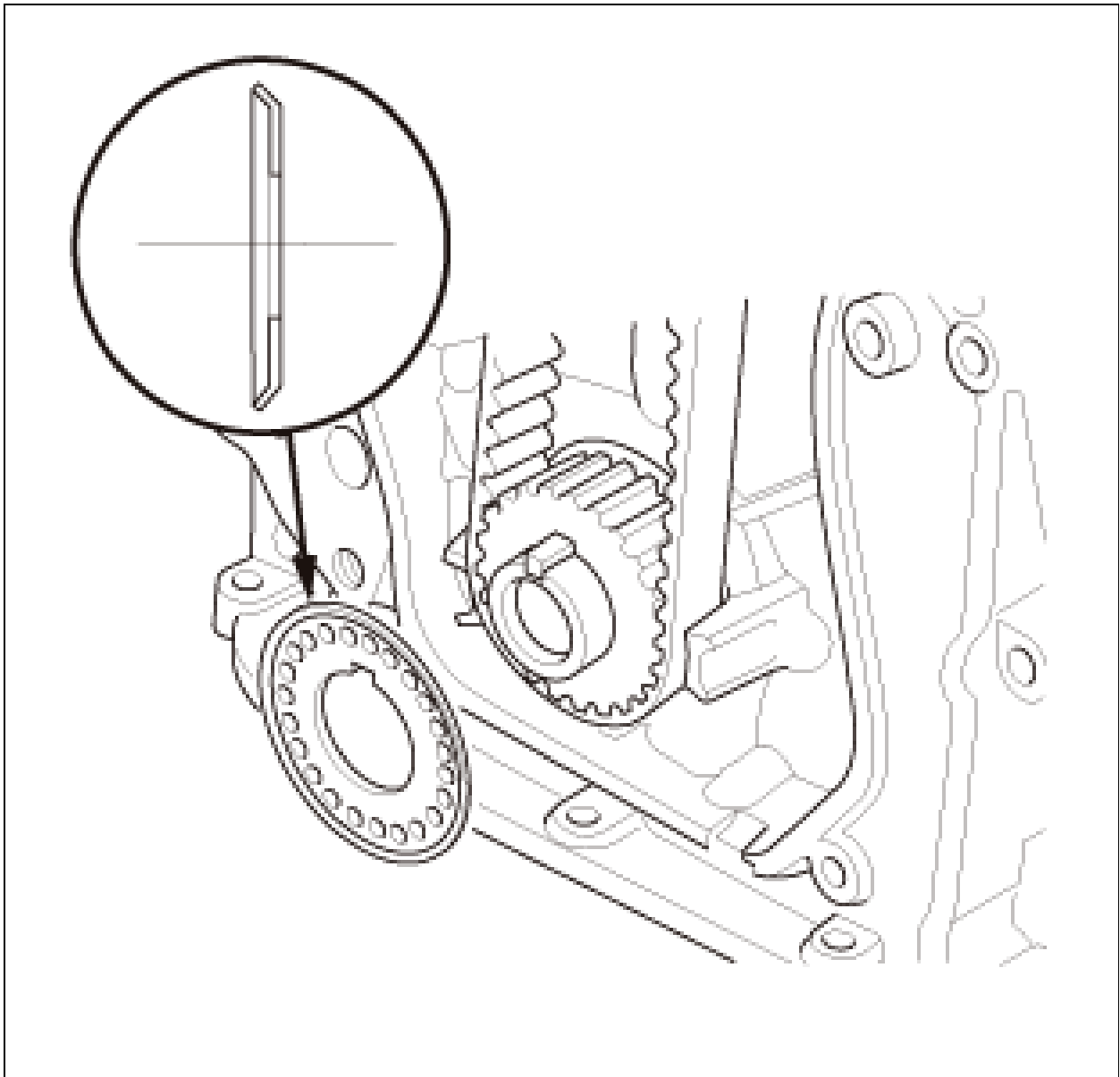

Courtesy of HONDA, U.S.A., INC.

12. Lower Cover - Install



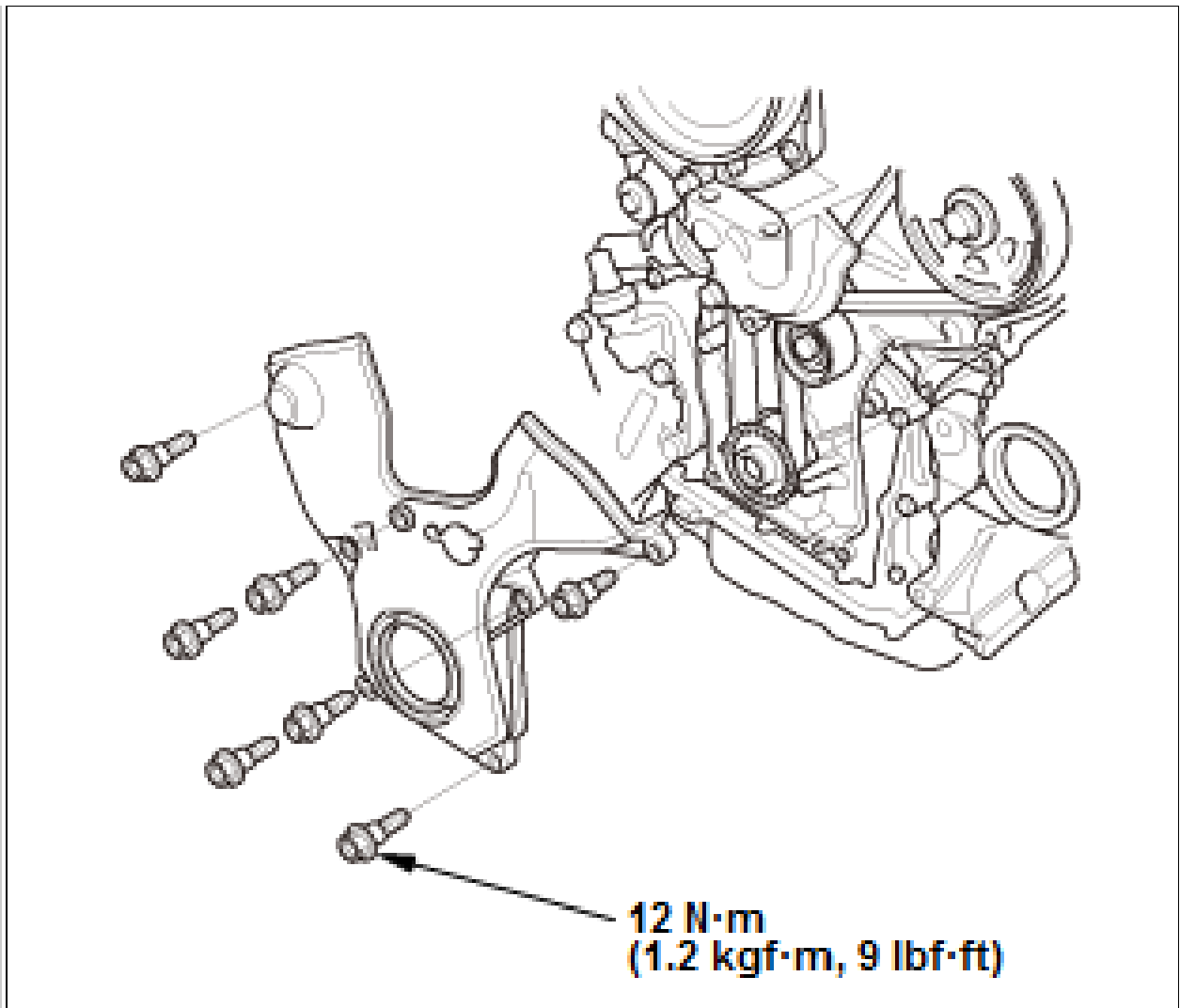

Courtesy of HONDA, U.S.A., INC.

13. Upper Cover - Install

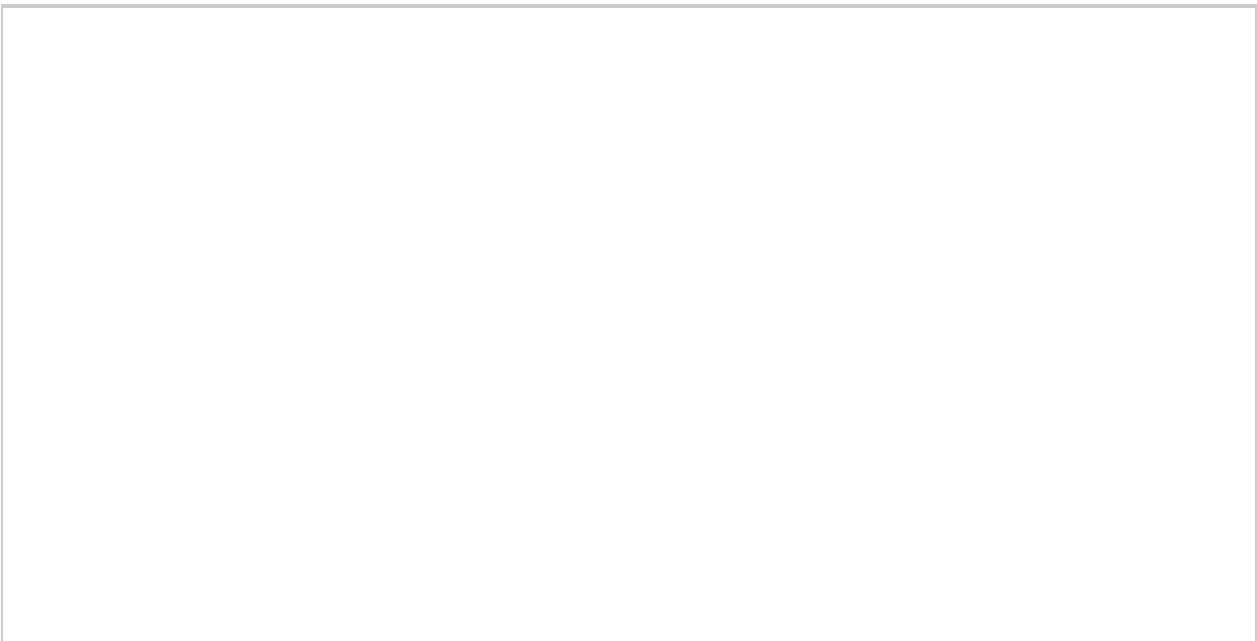

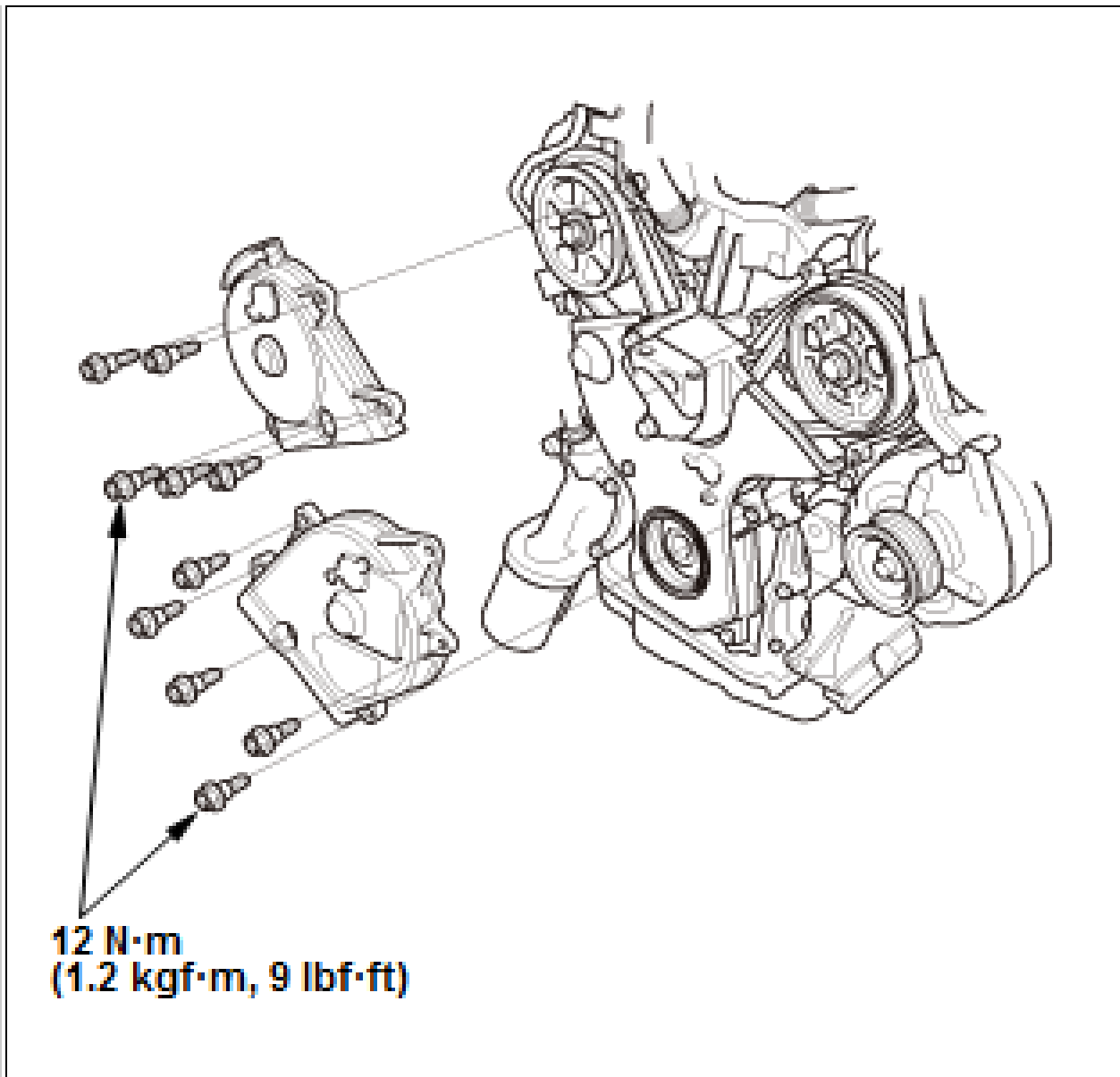

Courtesy of HONDA, U.S.A., INC.

14. Upper Half of Side Engine Mount Bracket - Install

15. Crankshaft Pulley - Install

16. Camshaft Timing - Check

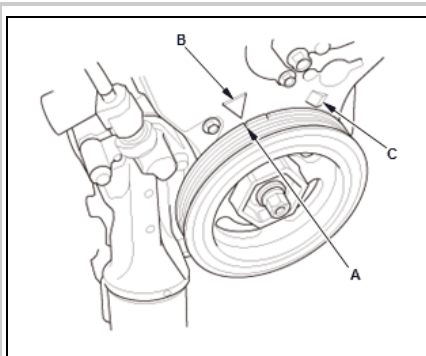

1. Rotate the crankshaft pulley about six turns clockwise so the timing belt positions itself on the pulleys
2. Turn the crankshaft pulley so its white mark (A) lines up with the pointer (B).

NOTE: *The other pointer (C) is not used.*

FRONT

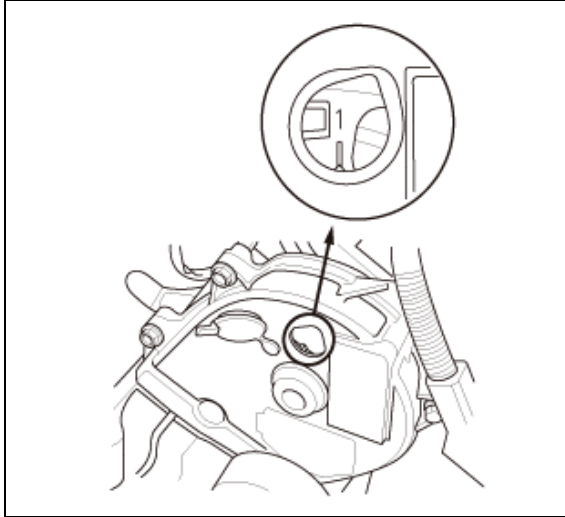

3. Check the camshaft pulley marks.

NOTE: *If the marks are not aligned, rotate the crankshaft 360 degrees, and recheck the camshaft pulley mark:*

1. If the camshaft pulley marks are at TDC, go to drive belt auto-tensioner install.
2. If the camshaft pulley marks are not at TDC, remove the timing belt and reinstall the timing belt.

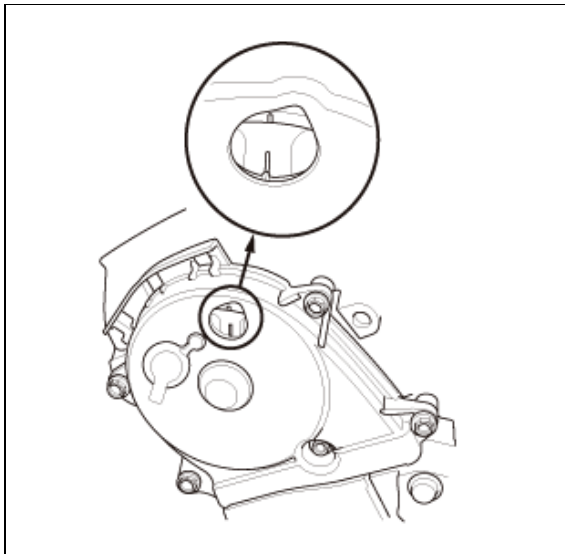

REAR

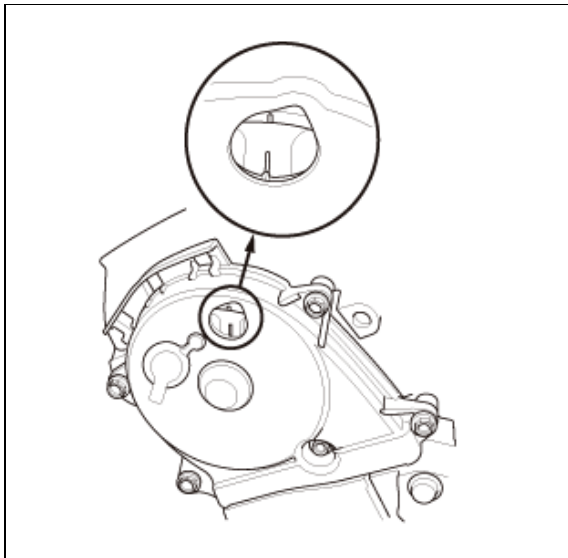
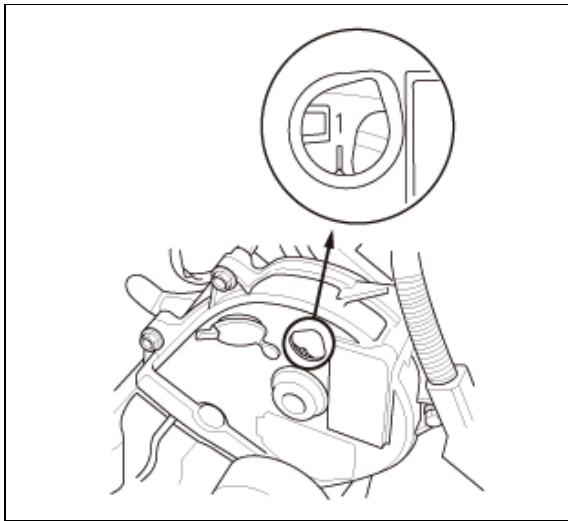

Courtesy of HONDA, U.S.A., INC.HONDA, U.S.A., INC.

- 17. Drive Belt Auto-Tensioner - Install
- 18. Engine Undercover - Install
- 19. Right Front Wheel - Install
- 20. CKP Pattern - Clear/Learn