

# INSPECTION/ADJUSTMENT > HEADLIGHT ADJUSTMENT (2016-17) > ADJUSTMENT

## 1. Headlight - Adjustment

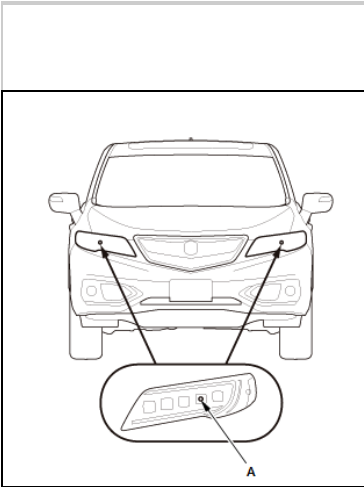

Courtesy of HONDA, U.S.A., INC.



Courtesy of HONDA, U.S.A., INC.

Headlights become very hot during use; do not touch them or any attaching hardware immediately after they have been turned off.

Before adjusting the headlights:

1. Park the vehicle on a level surface.
2. Make sure the tire pressures are correct.
3. The driver or someone who weighs the same should sit in the driver's seat (or use an equivalent weight).
4. Unload the vehicle.

1. Clean the outer lens so that you can see the center (A) of the headlights.

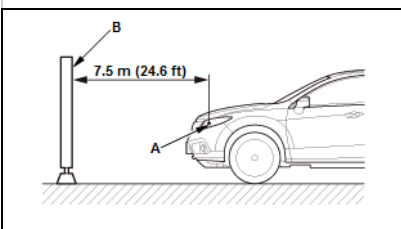

Courtesy of HONDA, U.S.A., INC.

2. Park the vehicle so that the center mark of the headlight (A) is 7.5 m (24.6 ft) away from a wall or screen (B).

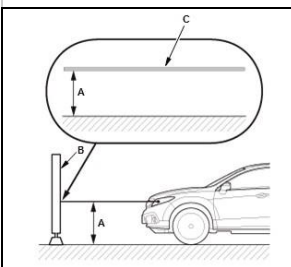

Courtesy of HONDA, U.S.A., INC.

3. Measure the height of the headlight's center mark (A), then on the wall or screen (B), mark the same height of the headlights with masking tape in a straight horizontal line (C).

4. Turn on the low beam headlights

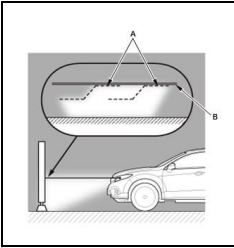

Courtesy of HONDA,  
U.S.A., INC.

5. To see if the headlights are adjusted properly, observe the beams of light projected on the wall or screen. The highest edge or "cut line" (A) of the headlights should be equal with the masking tape (B).

**NOTE:** *To help determine if a headlight is out of adjustment, block one of the beams with a large piece of cardboard or equivalent and observe the other beam on the wall or screen. Repeat this for the other headlight.*

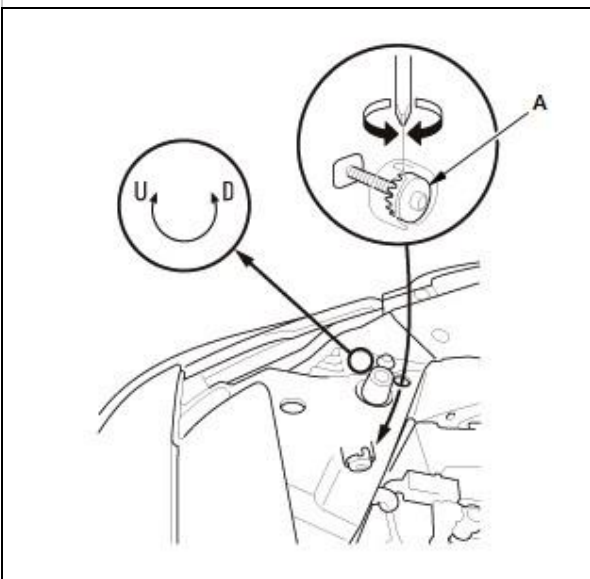

6. If adjustment is necessary, open the hood and adjust the headlights to local requirements by turning the adjuster (A).

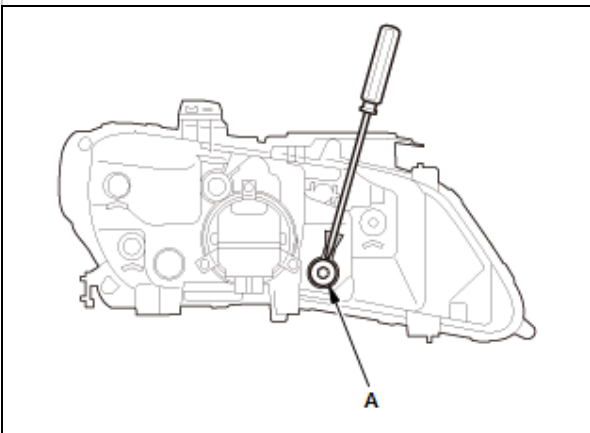

Courtesy of HONDA, U.S.A., INC. HONDA, U.S.A., INC.

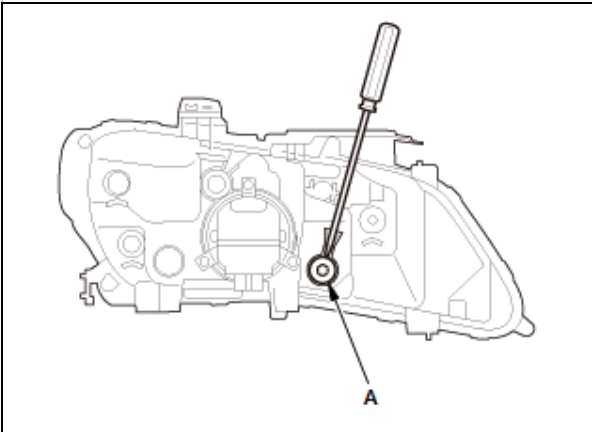
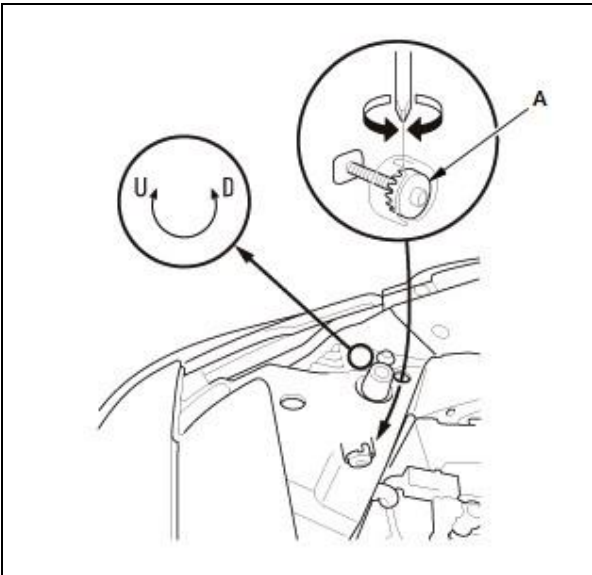

Courtesy of HONDA, U.S.A., INC. HONDA, U.S.A., INC.