

INSPECTION/ADJUSTMENT > DOOR POSITION ADJUSTMENT (2013-17) > ADJUSTMENT

NOTE: *Check for a flush fit with the body, then check for equal gaps between the front and rear doors, and between the doors, and the body. Check that the door and body edges are parallel.*

1. Front Fender Fairing - Remove

1. Remove the front fender fairing .

2. Door Position - Adjust

Fig 1: Front Door With Torque Specifications

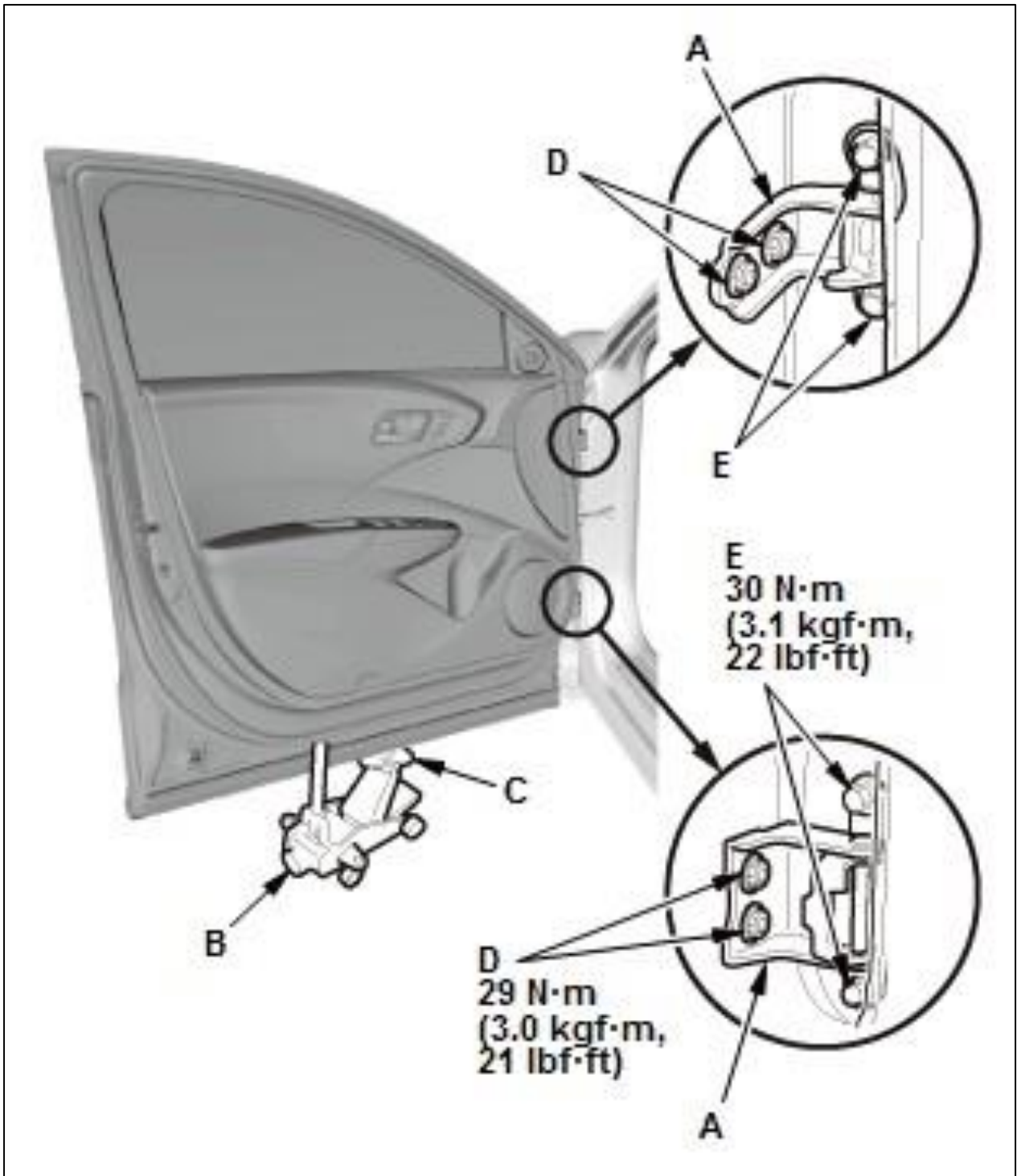
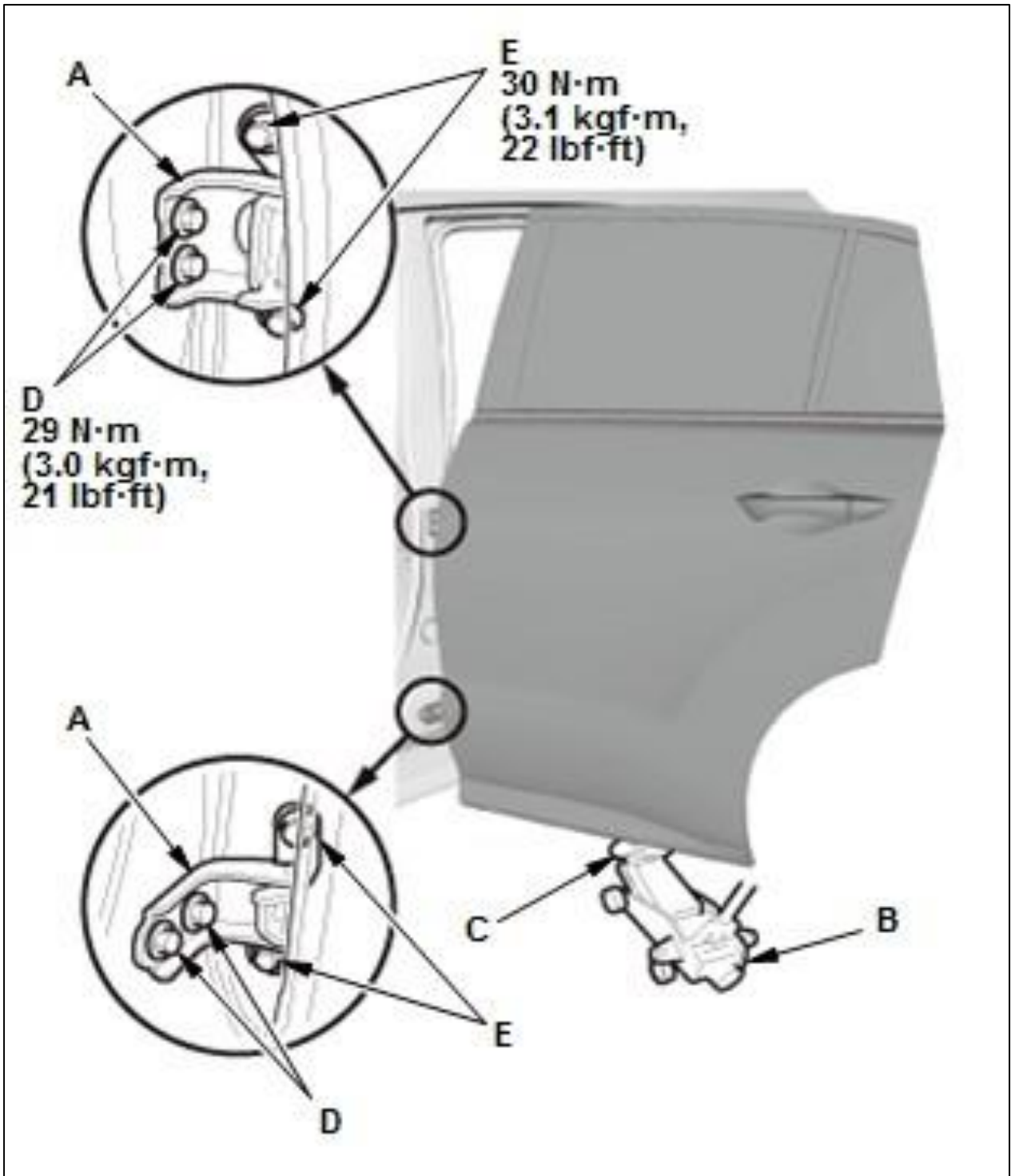

Fig 2: Rear Door With Torque Specifications



NOTE: Place the vehicle on a firm, level surface when adjusting the doors.

1. Adjust at the hinges (A):

1. Pad a floor jack (B) with shop towels (C), then use the jack to support the door while adjusting it.
2. Loosen the hinge mounting bolts (D) slightly, and move the door backward or forward, up or down as necessary to equalize the gaps.
2. If necessary, replace the door mounting bolts with the adjusting bolts made specifically for door adjustment, then adjust at the door: Loosen the door mounting bolts (E) slightly, and move the door up or down as necessary to equalize the gaps, and move it in or out until it is flush with the body.

NOTE: Refer to the Parts Catalog if you need use an adjusting bolt.

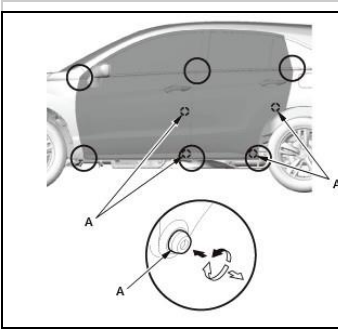

3. Check that the door and body edges are parallel. If necessary, adjust the door cushions (A) to make the rear of the doors flush with the body.
4. Make sure the door opens without popping or binding and latches securely without slamming. If not, adjust the door striker .
5. Apply touch-up paint to the hinge mounting bolts and around the hinges.

3. Front Fender Fairing - Install

1. Install the front fender fairing .

4. Water Leaks - Check

1. Check for water leaks .

INSPECTION/ADJUSTMENT > DOOR STRIKER ADJUSTMENT (2013-17) > ADJUSTMENT

1. Door Striker - Adjust

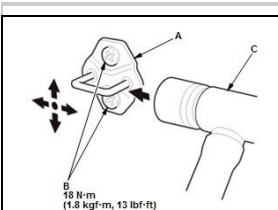

Make sure the door latches securely without slamming it. If necessary, adjust the striker (A): The striker can be adjusted slightly up or down, and in or out.

1. Loosen the screws (B)
2. Wrap the striker with a shop towel, then adjust the striker by tapping it with a plastic hammer (C). Do not tap the striker too hard
3. Lightly tighten the screws
4. Hold the outer handle out, and push the door against the body to be sure the striker allows a flush fit. If the door latches properly, tighten the screws to the specified torque, and recheck.

