

# Starting System

## Starter Replacement

1. Make sure you have the anti-theft code for the radio, then write down the frequencies for the radio's preset buttons.
2. Disconnect the battery negative cable, then disconnect the positive cable.
3. Remove the left drive shaft.
4. Remove the exhaust pipe A.
5. Disconnect the starter cable from the B terminal on the solenoid, then disconnect the BLK/WHT wire from the S (SOLENOID) terminal wire.

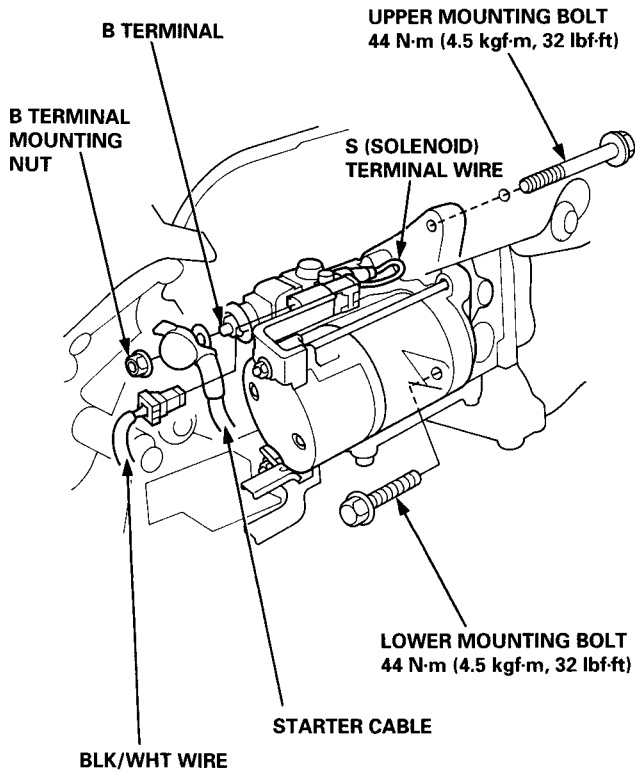

6. Remove the two bolts holding the starter, then remove the starter.
7. Install in the reverse order of removal.

NOTE: When installing the starter cable, make sure that the crimped side of the ring terminal is facing out.

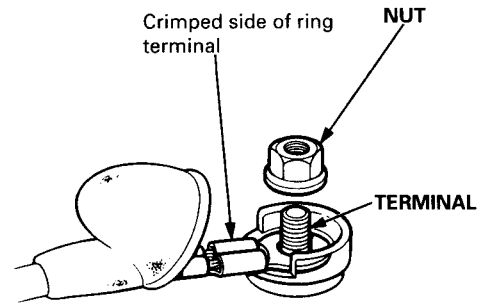

8. Connect the battery positive cable and negative cable to the battery.
9. Enter the anti-theft code for the radio, then enter the customer's radio station presets.