

Applies To: **ALL**

May 2, 2009

Vehicle Pulls or Drifts, and/or Steering Wheel Is Off-Center

(Supersedes 06-034, *Vehicle Pulling or Drifting*, dated October 16, 2007, to revise the information marked by the black bars)

(Replaces 90-007, *Steering Wheel Off-Center Adjustment at TQI*)

REVISION SUMMARY

The title description was revised.

SYMPTOM

While driving on a straight road, the vehicle pulls or drifts to the right or the left.

BACKGROUND

New tools were developed to help you diagnose and correct a pulling and/or steering wheel off-center issue. There is a diagnosis worksheet included to take on your test-drive and record your findings. These values are used to build the 15-digit DTC (diagnostic trouble code) that is required for your warranty claim. The last step in each repair procedure helps you create the correct code.

In the rare case that you have to repair a vehicle that pulls and has the steering wheel off-center, use **REPAIR PROCEDURE B** to file your warranty claim.

For more information, refer to Training Module SSC 44 – *Steering Drift or Pull Interactive Service Bulletin*.

PROBABLE CAUSES

Several conditions can cause the vehicle to pull or drift:

- Wheel alignment
- Tires
- Off-center steering wheel (no pulling or drifting, but a client may believe this is the case)

CORRECTIVE ACTION

Diagnose the problem using the special tools and the worksheet on page 4 that guides you to one of four repair procedures.

TOOL INFORMATION

Centering Tape (enough to diagnose 240 vehicles): T/N 07AAJ-001A300

Steering Drift Set Level: T/N 07AAJ-001A200

Steering Drift Set: T/N 07AAJ-001A140

Replacement Weight for Steering Drift Set: T/N 07AAJ-001A400

WARRANTY CLAIM INFORMATION

In warranty: The normal warranty applies.

OP#	Description	FRT
4213B0	Repair procedure A (tire-induced pull)	0.7
4313A1	Repair procedure B (four-wheel alignment)	1.6
4213A9	Repair procedure C (steering wheel off-center)	0.7
4213B1	Repair procedure D (tire-induced pull)	0.7

Failed Part: P/N 53560-SDA-A01

Defect Code: 07406

Symptom Code: 03602

Skill Level: Repair Technician

Diagnostic Trouble Code: To create the 15-digit DTC, see the applicable repair procedure.

Out of warranty: Any repair performed after warranty expiration may be eligible for goodwill consideration by the District Parts and Service Manager or your Zone Office. You must request consideration, and get a decision, before starting work.

TOOL DESCRIPTIONS

Holding Force Gauge



The holding force gauge measures the amount of pull on the vehicle. It is a bracket that counts as one weight, plus five removable weights.

During the test-drive, attach the bracket and the weights to the steering wheel on the side opposite the pulling direction. For example, if the vehicle pulls to the right, attach the bracket and weights to the left side of the steering wheel. Start with the maximum amount of weight on the steering wheel, and remove the weights until the vehicle drives in a straight line.



When recording the pull on the worksheet, write down the direction of the pull (left or right) and the number of weights required to balance the pull (one through six). For example, you have the bracket and two weights on the steering wheel. Record this as three weights.

NOTE: The bracket counts as one weight.

Road Crown Gauge



The road crown gauge measures the amount of road crown. Almost all roads have a crown to help drain water during rainstorms. Use the suction cup to attach the road crown gauge bracket to the vehicle in a vertical position. If necessary, bend the bracket until the gauge is vertical. Once you attach and align the road crown gauge, calibrate the gauge to zero. There are two ways to calibrate the gauge:

- Park the vehicle on a level surface, such as an alignment rack, and calibrate the gauge by moving the gauge until the ball is on the zero mark.
- If you do not have a perfectly flat surface, park the vehicle on a reasonably flat surface and note the gauge reading. Turn the vehicle 180° and, with the tires in the same spot, note the new gauge reading. Then move the gauge half of the difference. Example: Your first reading is +3 and, after moving the vehicle, the gauge reads -1. The difference is 4 degrees. Position the gauge to read +1.

NOTE: You must calibrate the gauge with the same weight in the vehicle that you will use for the test-drive. If you plan to have an assistant help you during the test-drive, calibrate the gauge while both of you are sitting in the vehicle.



Calibrate the road crown gauge.

Steering Wheel Offset Gauge

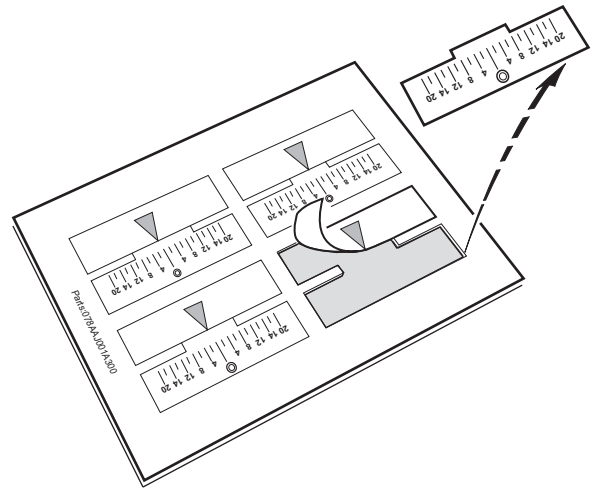

The steering wheel offset gauge is a sticker that attaches to the steering wheel and the steering column cover. Place the sticker on the steering wheel when the steering wheel is straight. When you test-drive the vehicle, you can read how many millimeters the steering wheel is off-center.

If the vehicle is pulling, repairing the pull may correct the steering wheel offset.



DIAGNOSTIC WORKSHEET

NOTE: Copy this page and have the service manager or consultant use it to interview the client, then take it on your test-drive for reference. Extra space is available to write down your answers. Attach a copy of your diagnosis to the repair order.

Service Manager or Consultant

Ask the client these questions. Circle or fill in the appropriate answers.

While driving straight, is the steering wheel straight?	Yes	No
If the answer in question 1 was no, is the steering wheel off to the left or the right?	Left	Right
Does the vehicle pull?	Yes	No
If the vehicle pulls, which direction does it pull? Some vehicles may pull both left and right. If this is the case, circle both left and right.	Left	Right

Does the vehicle pull all the time, some of the time, or on one particular road? If the vehicle pulls only on a particular road, describe the road.

Does the vehicle pull during acceleration, deceleration, or cruising?

When driving with one or more passengers, does the pull go away or stay the same?

Technician

NOTE:

- Circle or fill in the appropriate answers.
 - Place only one number in each box.
 - For road crown, write your reading as a whole number and a decimal. For example, to record 1.5°, write 1 in the first box and 5 in the second.
 - For steering wheel off-center readings, it is possible to have a measurement of more than 9 mm. Two boxes are provided for recording the measurement. If the value is less than 10, write 0 in the first box.
1. Check and adjust the tire pressure to the recommended pressure on the doorjamb label.
 2. Center the steering wheel, then attach the steering wheel offset gauge.
 3. Attach and calibrate the road crown gauge.

NOTE: Once you know the amount of road crown on a particular road, you do not need to use the road crown gauge.

4. Which direction is the road crown?	Left	Right
5. What is the average amount of road crown? (First digit)		
6. What is the average amount of road crown? (Second digit)		
7. Does the vehicle pull?	Yes - go to question 8.	No - go to question 11.
8. Which direction does the vehicle pull?	Left	Right
9. Attach the steering wheel weights to the steering wheel on the opposite side that the vehicle is pulling. As you drive, remove the weights one at a time until the vehicle goes in a straight line. How many weights did you use? NOTE: The bracket counts as one weight.		
10. Swap the left and right front tires, remove the steering wheel weights, then test-drive the vehicle again. Does the vehicle pull in the same direction?	Yes, vehicle pulls in same direction – Do REPAIR PROCEDURE B, then go to question 11.	No, vehicle pulls in opposite direction – Do REPAIR PROCEDURE A, then go to question 11.
11. Is the steering wheel off-center?	Yes - Go to question 12.	No - Vehicle is OK, return vehicle to the client.
12. Which direction is the steering wheel off-center?	Left	Right
13. How much is the steering wheel off-center? Record the measurement (first digit), then go to REPAIR PROCEDURE C.		
14. How much is the steering wheel off-center? Record the measurement (second digit), then go to REPAIR PROCEDURE C.		

REPAIR PROCEDURE A

NOTE: Do this repair procedure if, after doing step 10 of the test-drive, the vehicle pulled in the opposite direction after you swapped the front tires.

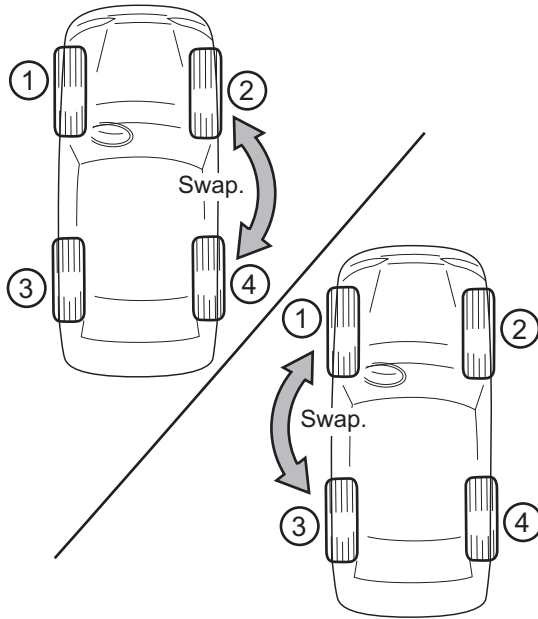

- Swap wheels 2 and 4 on the passenger's side of the vehicle, and test-drive again.
 - If the pull goes away, replace the tire on wheel 2, then go to step 3.
 - If the pull does not go away, put wheels 2 and 4 back to their original positions, and go to step 2.
- Swap wheels 1 and 3 on the driver's side of the vehicle, and test-drive again.
 - If the pull goes away, replace the tire on wheel 1, then go to step 3.
 - If the pull does not go away, use a known-good tire in position 1 and continue the diagnosis.
- Use your diagnostic worksheet to fill in the following table and build your 15-digit DTC.

Repair Procedure A		
Description	Box No.	Your Values
Repair code	1	T
Answer to question 4 (enter L or R)	2	
Answer to question 5	3	
Answer to question 6	4	
Answer to question 8 (enter L or R)	5	
Answer to question 9	6	
Enter the last eight digits of the DOT number on the tire you replaced.	7	
	8	
	9	
	10	
	11	
	12	
	13	
	14	
Not used	15	X

REPAIR PROCEDURE B

- Place the vehicle on a commercially available, computerized four-wheel alignment rack, and record the following measurements. Follow the equipment manufacturer's instructions.

NOTE: Enter each reading in decimal degrees. Example 30' = 0.5°.

What is the camber on the left-front wheel?	+	
	-	
What is the camber on the right-front wheel?	+	
	-	
What is the caster on the left-front wheel?	+	
	-	
What is the caster on the right-front wheel?	+	
	-	
What is the toe on the left-front wheel?	+	
	-	
What is the toe on the right-front wheel?	+	
	-	
What is the toe on the left-rear wheel?	+	
	-	
What is the toe on the right-rear wheel?	+	
	-	

- If any measurement is out of specification, inspect the suspension for any damage. Repair any damaged parts before continuing your diagnosis.
- Determine how the front wheel camber is affecting the pull. Pick the combination of left- and right-front camber that best matches the vehicle you are repairing, then note the camber thrust direction for that combination:

Left-Front Camber	Right-Front Camber	Camber Thrust Direction
Negative	Positive	Right
Positive	Negative	Left
Neutral	Positive	Right
Neutral	Negative	Left
Negative	Neutral	Right
Positive	Neutral	Left
Neutral	Neutral	None
Negative	Negative	None
Positive	Positive	None

NOTE:

- If the camber of both front wheels is negative, but one wheel is grossly more negative than the other, the camber thrust direction will be opposite the wheel with more negative camber (for example, if the **left**-front wheel is more negative, the camber thrust direction is **right**).
- If the camber of both front wheels is positive, but one wheel is grossly more positive than the other, the camber thrust direction will be the same as the wheel with more positive camber (for example, if the **left**-front wheel is more positive, the camber thrust direction is **left**).

4. Determine how the camber needs to be adjusted.

Direction the Vehicle Pulls	Camber Thrust Direction	Camber Adjustment
Left	Left or none	Left-front more negative, right-front more positive
Right	Right or none	Left-front more positive, right-front more negative
Left	Right	Left-front more negative, right-front more positive
Right	Left	Left-front more positive, right-front more negative

5. Adjust the camber as needed.

Front Camber Adjustment, Double Wishbone Suspension

- Loosen the front subframe bolts. See the applicable service manual for more information.

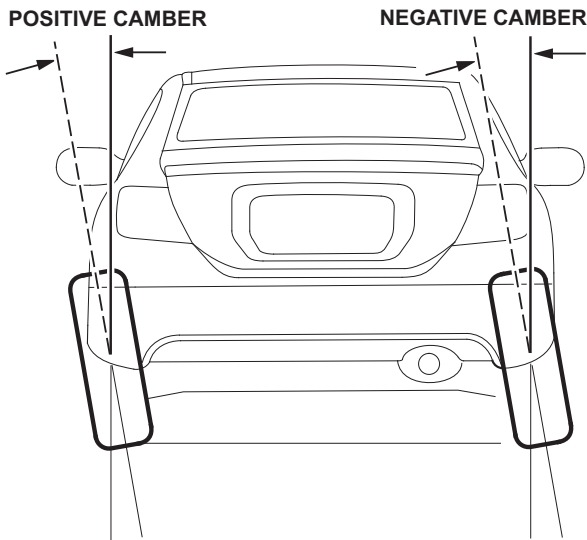

Front wheels viewed from rear of vehicle.

- Depending which way you need to shift the subframe, insert a pry bar between the subframe and body at both the front and rear positions of the subframe.

NOTE: Be careful not to damage the vehicle. You could bend and damage the frame and/or body if you apply too much pressure.

- Press on both pry bars to shift the subframe. It will move only a few millimeters. This should adjust the camber about 0.2–0.5°.
- While holding the subframe in place, have an assistant torque the subframe bolts to their proper torque.

Camber Adjustment, Strut Suspension

- Raise the vehicle, and remove the front tires.
- Loosen the damper pinch bolts and the flange nuts.
- Adjust the camber by moving the bottom of the damper within the range of the damper pinch bolt free play.

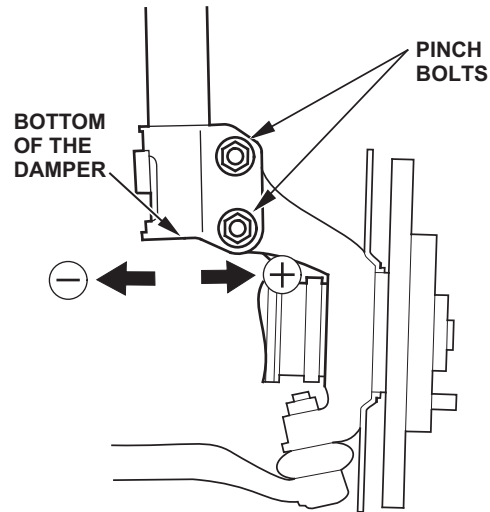

NOTE: Some vehicles have special pinch bolts that allow more adjustment. For more information, refer to the parts catalog.

- Tighten the damper pinch bolts to the specified torque.
- Reinstall the front wheels, and lower the vehicle. Bounce the front of the vehicle several times to stabilize the suspension.

6. Test-drive the vehicle to make sure it no longer pulls. If the steering wheel is now off-center by more than 2 mm, go to REPAIR PROCEDURE C.

7. Use your diagnosis worksheet to fill in the following table and build your 15-digit DTC.

NOTE: Enter each reading in decimal degrees.
Example 30' = 0.5°.

Repair Procedure B		
Description	Box No.	Your Values
Repair code	1	A
Answer to question 4 (enter L or R)	2	
Answer to question 5	3	
Answer to question 6	4	
Answer to question 8 (enter L or R)	5	
Answer to question 9	6	
Left camber (positive [P] or negative [N])	7	
Left camber measurement (enter the decimal reading, for example, for 0.2, enter 2)	8	
Right camber (positive [P] or negative [N])	9	
Right camber measurement (enter the decimal reading, for example, for 0.2, enter 2)	10	
Left caster - first digit	11	
Left caster - second digit	12	
Right caster - first digit	13	
Right caster - second digit	14	
Not used	15	X

REPAIR PROCEDURE C

- Make sure the steering wheel is centered.
 - Turn the steering wheel all the way to the right until it stops.
 - Turn the steering wheel all the way to the left, and count the number of revolutions until it stops.
 - Divide the number of revolutions in half, and turn the steering wheel until it is centered. For example, if it takes four revolutions of the steering wheel to go from lock to lock, two turns is centered.
 - If the steering wheel is off-center by a large amount (20 mm or more), it may not be centered on the steering column shaft. Reinstall the steering wheel before going to step 2.
- Place the vehicle on a lift, turn the steering wheel until it is centered, then raise the vehicle.

- Adjust the tie-rods. Use your measurements from questions 13 and 14 of the test-drive to make your adjustment.

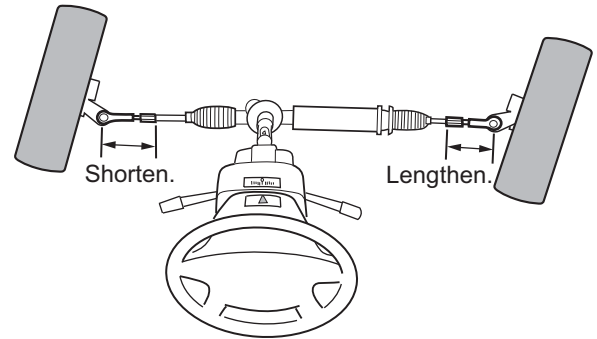

- If the wheels are pointed to the right, shorten the driver's side tie-rod, and lengthen the passenger's side.
- If the wheels are pointed to the left, shorten the passenger's side tie-rod, and lengthen the driver's side.
- Each 360° turn of the tie-rod equals about 8 mm of steering wheel adjustment. For example, a steering wheel is off-center by 4 mm, with the front wheels pointed right (when the steering wheel is centered). To correct the off-center, shorten the driver's side tie-rod by a half-turn, and lengthen the passenger's side tie rod by a half-turn.

- Use your diagnosis worksheet to fill in the following table and build your 15-digit DTC.

Repair Procedure C		
Description	Box No.	Your Values
Repair code	1	S
Answer to question 4 (enter L or R)	2	
Answer to question 5	3	
Answer to question 6	4	
Answer to question 12 (enter L or R)	5	
Answer to question 13 - 1st digit	6	
Answer to question 14 - 2nd digit	7	
Not Used	8	X
	9	X
	10	X
	11	X
	12	X
	13	X
	14	X
	15	X

REPAIR PROCEDURE D

Repair is complete. Use your diagnosis worksheet to fill in the following table and build your 15-digit DTC.

Repair Procedure D		
Description	Box No.	Your Values
Repair code	1	V
Answer to question 4 (enter L or R)	2	
Answer to question 5	3	
Answer to question 6	4	
Answer to question 8 (enter L or R)	5	
Answer to question 9	6	
Enter the last eight digits of the DOT number on either of the tires you swapped.	7	
	8	
	9	
	10	
	11	
	12	
	13	
	14	
Not used	15	X